



b70
DECO



User Manual

bernette

SWISS DESIGN

Table of Contents

IMPORTANT SAFETY INSTRUCTIONS	6	2.3 Attaching the Embroidery Module	28
Important Information	9	2.4 Embroidery Foot	29
1 My bernette Embroidery	11	Attaching the Embroidery Foot	29
1.1 Overview Machine	11	Selecting the Embroidery Foot	30
Overview front controls	11	2.5 Needle	30
Overview front	13	Inserting the Embroidery Needle	30
Overview Top	14	2.6 Threading	31
Overview back	14	Preparing the Threading	31
Overview Embroidery Module	15	Threading the Upper Thread	31
1.2 Accessory	16	Winding the Bobbin Thread	34
Included accessories	16	Threading the Bobbin Thread	36
Overview presser feet	17	2.7 Selecting the embroidery motif	37
1.3 Overview User Interface	17	2.8 Embroidery Hoops	38
Overview functions/visual information	17	Overview Embroidery Hoop Selection	38
Overview System Settings	18	Selecting the Embroidery Hoop	38
Overview Selection Menu Embroidery	18	Tear-away Stabilizers	39
Overview Functions and Views	18	Cut-away Stabilizers	39
1.4 Needle, Thread, Fabric	20	Using Adhesive Spray	39
Overview Needles	20	Using Spray Starch	39
Example for Needle Description	20	Using Iron-on Interfacing	39
Thread Selection	21	Using Paper-backed Adhesive Stabilizer	40
Needle/Thread Combination	21	Using Water-soluble Stabilizer	40
1.5 Important Embroidery information	22	Preparing the Embroidery Hoop	40
Upper Thread	22	Attaching the Hoop	42
Bobbin Thread	22	Overview Embroidery Functions	43
Choosing the Embroidery Design	23	Locating the Center of the Embroidery Design	43
Embroidery Test	23	Centering the Needle to the Embroidery Hoop	43
Embroidering motifs by third-party providers	23	Embroidery Arm Return	43
Underlay Stitches	23	Grid On/Off	44
The Size of the Embroidery Design	23	3 Setup Program	45
Satin or Leaf Stich	24	3.1 Embroidery Settings	45
Step Stitch	24	Adjusting the Upper Thread Tension	45
Connecting Stitches	24	Adjusting the Maximum Embroidering Speed	45
2 Embroidery Preparation	25	Calibrating the Embroidery Hoop	45
2.1 Connection and Switching On	25	Deactivating Securing Stitches	46
Connecting the Machine	25	Adjusting the Thread Cut	46
Use of the Power Cable (only USA/Canada)	25	Adjusting the Height of the Embroidery Presser Foot ..	47
Switching the Machine On	25	3.2 Selecting Personal Settings	47
Fixing the Touch Screen Pen	26	3.3 Monitoring Functions	48
2.2 Spool Pin	26	Activating the Upper Thread Indicator	48
Horizontal Spool Pin	26	Activating the Bobbin Thread Indicator	48
Second Spool Pin	27	3.4 Sound On/Off	48

Table of Contents

3.5	Machine Settings	48	Changing the Colors	64
	Adjusting the Brightness of the Display	48	Changing the Thread Brand	64
	Calibrating the Display	49	5.9 Embroidering the Embroidery Design	65
	Back to basic setting	49	Overview Embroidery Menu	65
	Updating the Machine Firmware	50	Adding Basting Stitches	65
	Checking the Firmware Version	50	Moving the Hoop	65
	Reviewing the Total Number of Stitches	51	Embroidery Sequence Control when the Thread Breaks	66
	Selecting a Language	51	Cutting Connecting Stitches	66
4	System Settings	52	Multi-colored Embroidery Design On/Off	67
4.1	Calling up the tutorial	52	Color Indication	67
4.2	Using eco Mode	52	5.10 Administering Embroidery Designs	67
4.3	Cancelling Any Alterations with «clr»	52	Administering Embroidery Designs	67
5	Creative Embroidering	53	Saving Embroidery Designs in the Personal Memory	67
5.1	Overview Embroidering	53	Saving the Embroidery Design on the USB Stick	68
	Selecting and Changing the Embroidery Design	53	Overwriting the Embroidery Design in the Personal Memory	68
	Overview Editing Embroidery Design	54	Overwriting the Embroidery on the USB Stick	68
	Moving the Embroidery Design	54	Loading an Embroidery Design from the Personal Memory	69
5.2	Selecting and Changing the Embroidery Design	55	Loading an Embroidery Design from the USB Stick	69
5.3	Checking the Embroidery Time and the Embroidery Design Size	55	Deleting an Embroidery Design from the Personal Memory	69
5.4	Regulating the Speed	55	Deleting an Embroidery Design from the USB Stick	69
5.5	Editing the Embroidery Design	56	6 Embroidery	70
	Overview Editing Embroidery Design	56	6.1 Embroidering via the Button «Start/Stop»	70
	Scaling Up the Embroidery Design View	56	6.2 Increasing the Embroidery Speed	70
	Downsizing the Embroidery Design	56	6.3 Adjusting the Upper Thread Tension	71
	Moving the embroidery design view	57	7 BERNINA CutWork Tool	72
	Moving the embroidery design in enlarged view	57	7.1 Attaching Cutwork Tool	72
	Moving the Embroidery Design	57	7.2 Start to Cut	73
	Rotating the Embroidery Design	58	8 Maintenance and Cleaning	74
	Altering the Embroidery Design Size Proportionally	58	8.1 Cleaning and Maintenance Intervals	74
	Mirroring Embroidery Designs	58	8.2 Cleaning the Display	74
	Checking the Size and the Position of the Embroidery Design	59	8.3 Cleaning the Feed Dog	74
	Deleting an Embroidery Design	59	8.4 Cleaning the Hook	75
5.6	Creating Lettering	60	8.5 Oiling the Needle Bar	76
	Overview Embroidery Alphabets	60	9 Errors and Faults	77
	Creating Words/Sentences	60	9.1 Troubleshooting	77
	Editing Words/Sentences	61	9.2 Error messages	79
	Bending the Text	62	10 Technical data	83
	Altering the Stitch Density	62	11 Appendix	84
5.7	Combining Embroidery Designs	63	11.1 Overview Embroidery Desings	84
	Combining Embroidery Designs	63		
	Deleting a Single Embroidery Design	63		
5.8	Changing the Colors of the Embroidery Design	63		
	Overview Changing the Color	63		

Editing the Embroidery Design	84
Embellishment	84
Quilt Designs	86
Borders and Lace	88
Children	89
Flowers	90
Seasons	92
Asia	94
Sport/Hobby	95
Animals	97
CutWork	99
Campaign	100
Index	101

IMPORTANT SAFETY INSTRUCTIONS

Please be aware of the following basic safety instructions when using your machine. Before using this machine, read instruction manual carefully.

DANGER

To protect against electric shock, the following instructions must be observed.

- Never leave the machine unattended when it is connected to the power supply.
- Immediately after use and before cleaning, switch off the machine and disconnect the power cable from the outlet.

In order to protect against injury, the following instructions must be adhered to.

- Do not look directly into the LED lamp with optical instruments (e. g. magnifying glass).
- If the LED lamp is damaged or defective, have the LED lamp checked or repaired at your local authorized bernette dealer.
- Switch off the machine before working in the needle area.
- Before starting the machine, close all covers.

WARNING

To reduce the risk of burns, fire, electric shock or injury to persons, the following instructions must be observed.

General Facts

- This machine may only be used for the purpose described in this instruction manual.

Working Environment

- Do not use the machine outdoors.
- Only use the machine in dry rooms.
- Do not use the machine in a humid area.
- Do not use the machine in rooms where aerosol products (sprays) are being used.
- Do not use the machine in rooms where oxygen is dispensed.

Technical Condition

- Never use the machine when it is damp.
- Do not use the machine if it is not working properly.

- Do not use the machine if a cable or the plug is damaged.
- Do not use the machine if it has been dropped, damaged or has fallen into water.
- If the machine is damaged or does not work properly, have the machine checked or repaired by your local authorized bernette dealer.
- Keep all ventilation openings of the machine and the foot control free of lint, dust and loose cloth.
- Do not use the machine if the ventilation openings are blocked.

Accessories and Supplies

- Only use the accessories recommended by the manufacturer.
- Always use the original bernette Stitch Plate.
An incorrect stitch plate can result in needle breakage.
- Use only straight needles of good quality.
Bent or damaged needles can cause needle breakage.
- This machine is double-insulated (except for USA, Canada and Japan).
Use only identical replacement parts. See instructions for Servicing of double-insulated products.
- To lubricate the machine, only use oil recommended by bernette.

Safety Instructions

- While operating the machine, all protective inserts must be in place and all covers must be closed.

Appropriate Use

- The machine may be used, cleaned and maintained by children older than eight or by people with reduced physical, sensory or mental capabilities or if there is a lack of experience and knowledge as long as they have been given instructions.
- Furthermore, these persons must be supervised while working with the machine, and/or they must know the safe operation of the machine and be aware of the resulting hazards.
- Children are not allowed to play with the system.
- Special care should be taken when the machine is operated by or in the presence of children.
- Only use the machine with the supplied power cable.
- USA and Canada only: Do not connect power plug NEMA 1-15 to circuits exceeding 150 volt-to-ground.
- Only use this machine with the supplied foot control of type .
- Do not insert any objects into the openings of the machine.

- Do not place any objects on the foot control.
- While sewing, guide the fabric gently.
Pulling and pushing the fabric can cause needle breakage.
- Keep fingers away from all moving parts.
- Special care is required in the needle area.
- For activities in the needle area - such as threading the needle, changing the needle, threading the looper or changing the presser foot - switch off the machine.
- To switch off, set the power switch to «0».
- When protective covers are removed, when the machine is oiled or when other cleaning and maintenance operations mentioned in this instruction manual are carried out, switch off the machine and disconnect the power plug from the outlet.
- Pull the plug out of the outlet by pulling on the plug. Do not pull on the cable.

Important Information

Availability of the Instruction Manual

The short manual is part of the machine.

- Keep the short manual of the machine in a suitable place near the machine and have it ready for reference.
- The latest version of the detailed instruction manual can be downloaded at www.bernette.com.
- When passing on the machine to a third party, enclose the short manual of the machine.

Proper use

Your bernette machine is conceived and designed for private household use. It answers the purpose to embroider fabrics and other materials as it is described in this instruction manual. Any other use is not considered proper. bernette assumes no liability concerning consequences resulting from an inappropriate usage.

Equipment and Scope of Delivery

Example images are used in these instructions for the purposes of illustration. The machines shown in the images and the accessories shown therefore do not always match the actual items included with your machine. The supplied accessory can vary depending on the country of delivery. You can acquire any accessories mentioned or shown that are not included in the scope of delivery as optional accessories from a specialist bernette dealer. Further accessories can be found at www.bernette.com.

For technical reasons and in order to improve the product, changes may be made to the equipment of the machine and the scope of delivery at any time and without prior notice.

Servicing of Double-insulated Products

In a double-insulated product two systems of insulation are provided instead of grounding. No grounding means is provided on a double-insulated product nor should a means for grounded be added to the product. Servicing a double-insulated product requires extreme care and knowledge of the system and should only be done by qualified service personnel. Replacement parts for a double-insulated product must be identical to the original parts in the product. A double insulated product is marked with the words: «Double-Insulation» or «double-insulated».



The symbol may also be marked on the product.

Environmental Protection

BERNINA International AG is committed to environmental protection. We strive to minimize the environmental impact of our products by continuously improving product design and our technology of manufacturing.



The machine is labeled with the symbol of the crossed-out wastebasket. This means that the machine should not be disposed of in household waste when it is no longer needed. Improper disposal can result in dangerous substances getting into the groundwater and thus into our food chain, damaging our health.

The machine must be returned free of charge to a nearby collection point for waste electrical and electronic equipment or to a collection point for the reuse of the machine. Information on the collection points can be obtained from your local administration. When purchasing a new machine, the dealer is obliged to take back the old machine free of charge and dispose of it properly.

If the machine contains personal data, you are responsible for deleting the data yourself before returning the machine.

Explanation of Symbols

 **DANGER**

Designates a danger with a high risk which can lead to serious injuries or even death unless it is avoided.

 **WARNING**

Designates a medium-risk hazard which can lead to serious injuries if not avoided.

 **CAUTION**

Designates a low-risk hazard which can lead to minor or moderate injuries if not avoided.

NOTICE

Designates a hazard which can lead to material damage if not avoided.

1 My bernette Embroidery

1.1 Overview Machine







Overview front controls



- | | | | |
|---|------------------------------|----|---|
| 1 | Sewing Light | 6 | Needle Up/Down |
| 2 | Thread Cutter | 7 | Upper Multi-function Knob |
| 3 | Presser Foot Up/Down | 8 | Lower Multi-function Knob |
| 4 | Start/Stop | 9 | Center of Embroidery Design |
| 5 | Check Embroidery Design Size | 10 | Centering the Needle to the Embroidery Hoop |

Operating Components

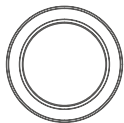
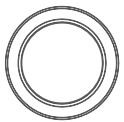
Number	Operating Component	Name	Purpose
1		Sewing Light	To switch the sewing light on or off, push the button «Sewing Light».

Number	Operating Component	Name	Purpose
2		Thread Cutter	<ul style="list-style-type: none"> > Press the «Thread Cutter» button in order to cut the upper and lower threads automatically.
3		Presser Foot Up/Down	<ul style="list-style-type: none"> > Press the «Presser Foot Up/Down» button to raise the presser foot into a hovering position. > Press the button «Presser Foot Up/Down » to raise the presser foot.
4		Start/Stop	<p>The button «Start/Stop» is used to change the presser foot position and to start the machine.</p> <ul style="list-style-type: none"> > To start the machine, keep the button «Start/Stop» pressed for 2 seconds. > To bring the presser foot into its highest position, press «Start/Stop» briefly. > Press the «Start/Stop» button again to raise the presser foot into hovering position.
5		Check Embroidery Design Size	<ul style="list-style-type: none"> > To position the embroidery hoop according to the needle position on the display, press the button «Check Embroidery Design Size».
6		Needle Up/Down	<ul style="list-style-type: none"> > To thread the bobbin thread, press «Needle Up/Down».
7		Upper Multi-function Knob	With the «Upper Multi-function Knob» setting values can be changed in the embroidering and the Setup Program.
8		Lower Multi-function Knob	Use the «Lower Multi-function Knob» change the setting values in the embroidery and setup program.
9		Center of Embroidery Design	<ul style="list-style-type: none"> > Touch the icon «Center of Embroidery Design» to position the hoop so that the needle is placed exactly over the center of the embroidery design.
10		Centering the Needle to the Embroidery Hoop	<ul style="list-style-type: none"> > To facilitate the threading of the needle and to get enough free space from the needle to the embroidery frame, touch the icon «Center Embroidery Hoop to the Needle».

Overview front



- | | | | |
|---|----------------------------------|----|----------------------|
| 1 | Connection for embroidery module | 7 | Thread cutter |
| 2 | Stitch plate cover | 8 | Slide speed control |
| 3 | Stitch plate | 9 | Thread take-up lever |
| 4 | Embroidery foot | 10 | Top cover |
| 5 | Sewing light | 11 | LCD Display |
| 6 | Needle threader | | |

Overview Top

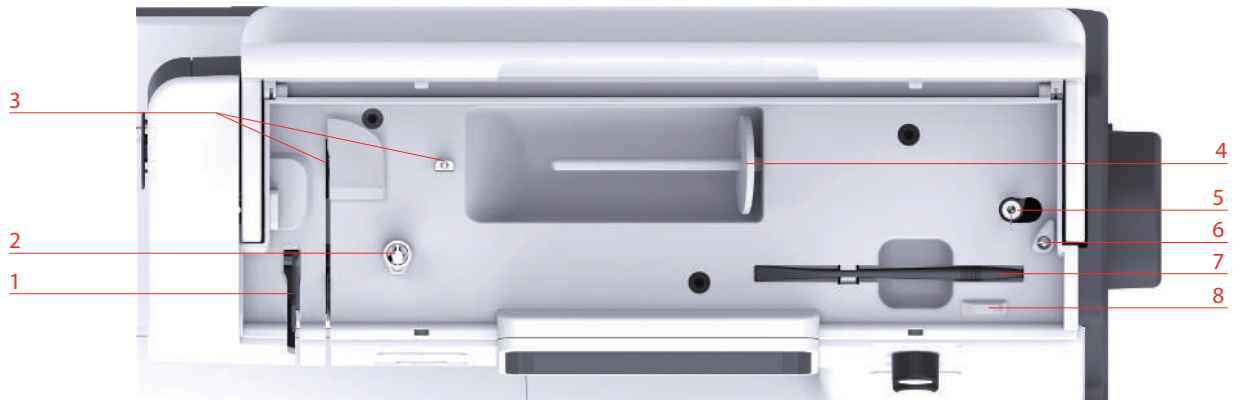

- | | | | |
|---|--------------------------|---|--|
| 1 | Thread Take-up Lever | 5 | Winding Unit and Holder for Second Spool Pin |
| 2 | Bobbin Winder Pretension | 6 | Stopper Winding Unit |
| 3 | Thread Guide | 7 | Touchscreen Pen |
| 4 | Spool Pin | 8 | Thread Cutter |

Overview back

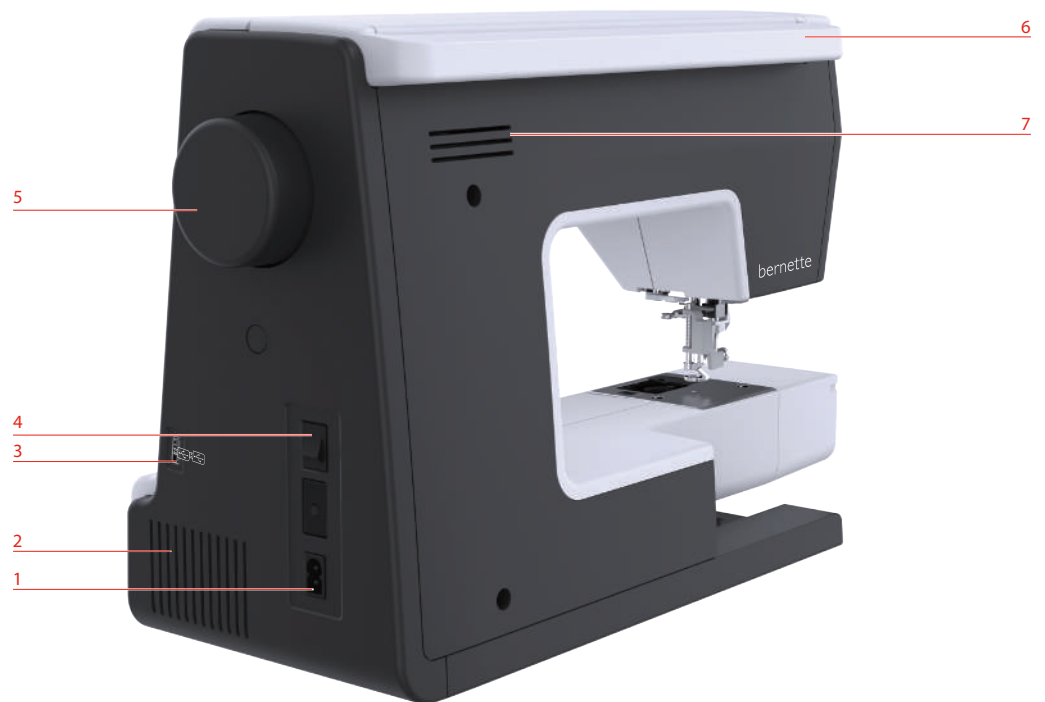

- | | | | |
|---|----------------------------|---|-----------------|
| 1 | Connection for power cable | 5 | Handwheel |
| 2 | Air vents | 6 | Carrying handle |
| 3 | USB port | 7 | Air vents |
| 4 | Power switch | | |

Overview Embroidery Module

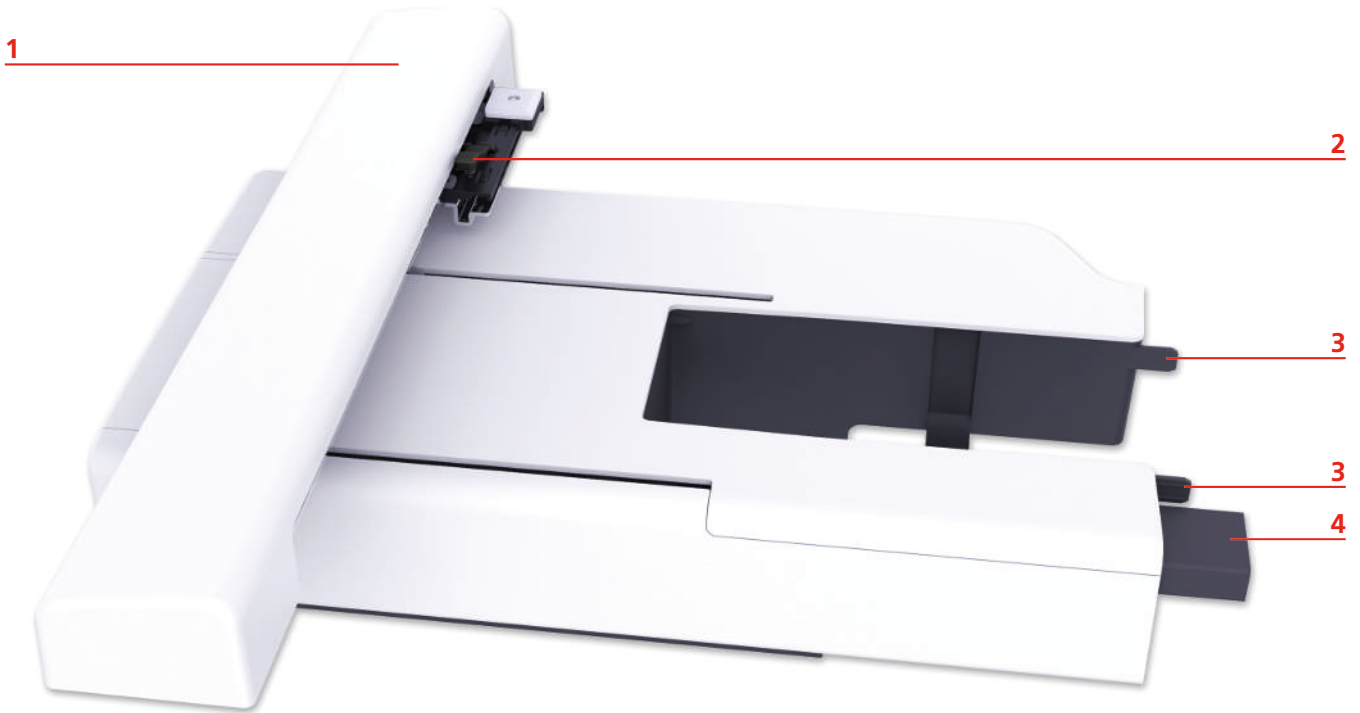

- | | | | |
|---|--------------------------------|---|---------------------------|
| 1 | Embroidery Arm | 4 | Connection to the Machine |
| 2 | Coupling for Securing the Hoop | 5 | Release Button |
| 3 | Guide Rails for the Machine | | |











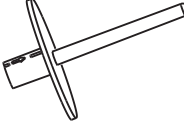

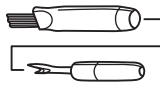
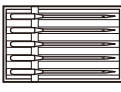
1.2 Accessory

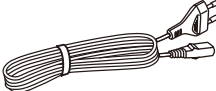
Included accessories

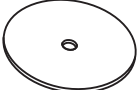
Visit www.mybernette.com/accessories for more accessory information.

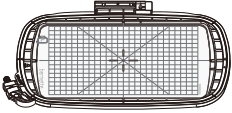
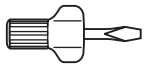
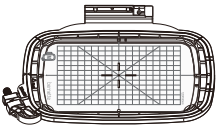
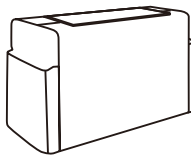
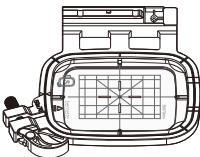

Illustration	Name	Illustration	Name
	Bobbin (3x)		Second spool pin
	Spool net		Touchscreen pen
	Brush/ Seam ripper		Selection of needles
	Spool disc large		Power cable
	Spool disc middle (1x)		Felt disc
	Spool disc small		Embroidery hoop large, 160 x 260 mm with embroidery template
	Screwdriver		Embroidery hoop medium, 120 x 180 mm with embroider template
	Dust cover		Embroidery hoop small, 50 x 70 mm with embroidery template
	Lubricator		

Overview presser feet

Illustration	Name	Purpose
	Hopper embroidery foot (JX)	To embroider
	Embroidery foot (JL)	To embroider

1.3 Overview User Interface

Overview functions/visual information

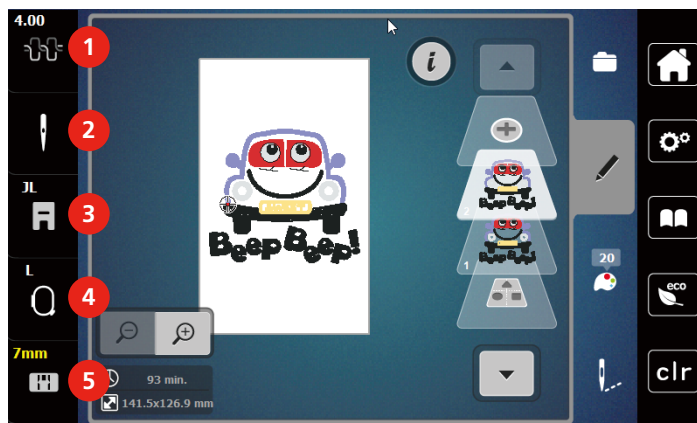

- | | | | |
|---|---|---|---|
| 1 | Upper thread tension | 4 | Embroidery hoop display/Embroidery hoop selection |
| 2 | Needle selection | 5 | Stitch plate display |
| 3 | Embroidery foot display/Embroidery foot selection | | |

Overview System Settings

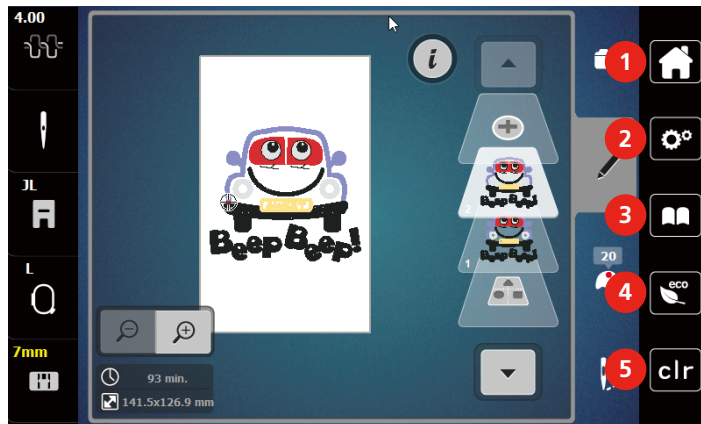

- | | | | |
|---|---------------|---|-------------------------|
| 1 | Home | 4 | eco Mode |
| 2 | Setup Program | 5 | Back to Default Setting |
| 3 | Tutorial | | |



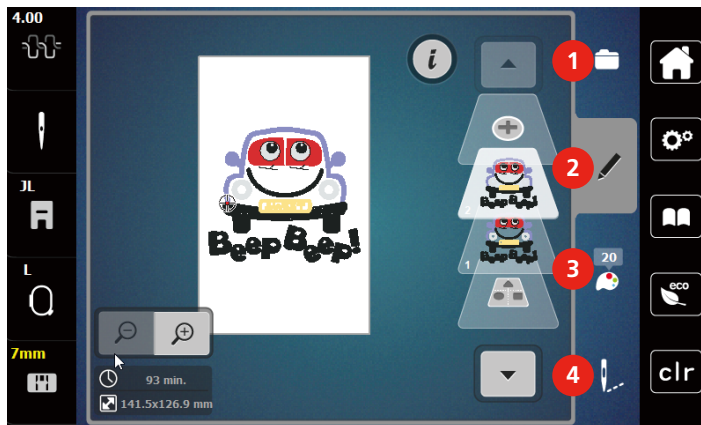





Overview Selection Menu Embroidery



- | | | | |
|---|-------------|---|---------------------|
| 1 | «Selection» | 3 | «Color Information» |
| 2 | «Edit» | 4 | «Embroidery» |

Overview Functions and Views

Illustration	Name	Purpose
	Close	The display is closed and the previously made adjustments are saved.
	«Plus» / «Minus»	Change setting values.
	Confirm	Confirms the previously adjusted alterations. The display is closed.

Illustration	Name	Purpose
	Cancel	The process is canceled. The display is closed and the previously made adjustments are not saved.
	Slide	By moving the slide the setting values are changed.
	Switch	Activates or deactivates functions.
	Process Navigation	With the process navigation, you can return from any display to the previous the display.
	Machine	To load or save motifs on the machine.
	USB Stick	To load or save embroidery designs on the USB stick.
	USB Storage Space	The percentage of used USB storage (%) will be displayed in the green bar icon.
	Swipe Function	By swiping the display using the touchscreen pen or the finger upwards or downwards, further functions can be displayed.
	Yellow-framed Icon	Tap the yellow-framed icon to reset the changes to the default setting.

1.4 Needle, Thread, Fabric

Needles will wear down over time. Therefore, the needle should be replaced regularly. Only a perfect point results in a good stitching result. In general, the thinner the fabric, the finer the needle. The illustrated needles are either standard or optional accessory, depending on the machine.

- Needle sizes 70, 75: for light-weight fabrics.
- Needle sizes 80, 90: for medium fabrics.
- Needle sizes 100: for heavy fabrics.

Overview Needles

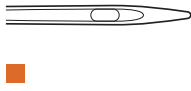
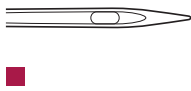
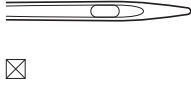
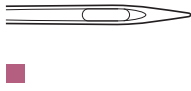
Illustration	Needle Name	Needle Description	Purpose
	Jersey/ Embroidery Needle 130/705 H SUK 80/12	With a medium ball point.	For woven fabrics (light, medium, heavy-weight), knitwear, plastic. For general sewing, sewing on buttons and buttonholes, zippers, hems and topstitching, decorative sewing, embroidery.
	Embroidery Needle 130/705 H-E 75/11 – 90/14	With a light ball point and a particularly wide eye and wide groove.	For woven fabrics (light, medium, heavy-weight), knitwear. For voluminous and woolen threads. For general sewing, sewing on buttons and buttonholes, zippers, hems and topstitching, decorative sewing, embroidery.
	Fine Fabrics Needle 130/705 H SES 70/10 – 90/14	With a light ball point.	For fine, delicate materials, such as velvet. For general sewing, sewing on buttons and buttonholes, zippers, hems and topstitching, decorative sewing, embroidery, patchwork, quilting.
	Metafil Needle 130/705 H METAFIL 80/12	With medium ball point and long eye (2 mm).	For woven fabrics (light, medium, heavy-weight), knitwear. For sewing with special effects and fancy threads, especially metallic threads. For embroidery with metallic thread. For hems and topstitching, decorative sewing and embroidery.

Example for Needle Description

The 130/705 system, which is the most common for household machines, is explained by the following picture of a Jersey/Stretch needle.

	<p>130/705 H-S/70</p> <p>130 = Shank length (1)</p> <p>705 = Flat shank (2)</p> <p>H = Needle scarf (3)</p> <p>S = Needle point (here medium ball point) (4)</p> <p>70 = Needle size 0.7 mm (5)</p>
---	---

Thread Selection

For a perfect sewing result, thread and fabric quality play an important role.

We recommend purchasing quality threads to achieve good sewing results.

- Cotton threads have the advantage of being a natural fiber and therefore are especially suitable for sewing cotton fabrics.
- Mercerized cotton threads have a slight sheen that is not lost with washing.
- Polyester threads have a high tensile strength and is particularly colorfast.
- Polyester threads are more flexible and are recommended where a strong and elastic seam is required.
- Rayon threads are made of natural fibers and have a brilliant sheen.
- Rayon threads are suitable for decorative stitches and achieve a more beautiful effect.

Needle/Thread Combination

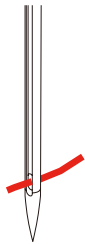
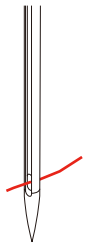
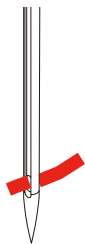
	<p>The needle/thread combination is correct, when the thread fits perfectly into the long groove and goes easily through the needle eye. The thread can be optimally sewn.</p>
	<p>The thread can break and skipped stitches can occur when there is too much clearance in the long groove and the needle eye.</p>
	<p>The thread can break and get stuck when the thread scrapes against the edge of the long groove not fit well into the needle eye optimally.</p>

1.5 Important Embroidery information

Upper Thread

A good quality thread (name-brand manufacturer) is essential for embroidery so that the embroidery is not affected negatively because of poor thread or thread breakage.

Embroidery is particularly effective if you use 40wt glossy rayon or polyester embroidery threads as upper threads. They are available in a wide range of colors for beautiful embroidery.

- Polyester with a brilliant sheen is a hard-wearing, colorfast thread and has a high tensile strength which is suitable for all types of embroidery.
- Rayon is a soft viscose fiber with a brilliant sheen and suitable for fine, delicate embroidery, or items that will not receive excessive wear and tear.
- Metallic thread is a light to medium-weight thread suitable for special effects in embroidery.
- When working with metallic threads, the automatic bobbin thread cutter should be deactivated. The other thread cutters shouldn't be used either because the knives are likely to wear off very quickly.
- When using metallic threads, the speed and the upper thread tension should be reduced.



Bobbin Thread

In most cases black or white bobbin thread is used for embroidering. When both sides should have the same look, it is recommended to use the same color for bobbin and upper thread.

- Bobbin Fill is an especially soft and light polyester thread which is suited to be used as bobbin thread. This special bobbin thread ensures a steady thread tension and an optimal intertwining of the upper and bobbin thread.
- Darning and embroidery threads are fine mercerized cotton threads which are suitable for embroidery on cotton.



Choosing the Embroidery Design

Simple designs with a low stitch count are suitable for embroidery on fine material. Densely embroidered designs, e. g. embroidered designs with multiple color and embroidery direction changes, are suitable for medium and heavy-weight material.

Embroidery Test

For the embroidery test, always use the original material reinforced with the same stabilizer as will be used later. For the embroidery test it is recommended to use the same colors, threads and needles which are planned to be used for the embroidery project.

Embroidering motifs by third-party providers

bernette recommends loading embroidery designs of any file format onto the machine or onto a USB stick using the free program «ART-Link» or the «BERNINA Toolbox». «ART-Link» ensures that embroidery designs are read and embroidered correctly. «ART-Link» can be downloaded for free at www.bernina.com.

Underlay Stitches

Underlay stitches are the foundation of a motif and are used to stabilize the base material and hold it in shape. They also prevent the covering stitches of the motif from sinking into the knit or the nap of the material.

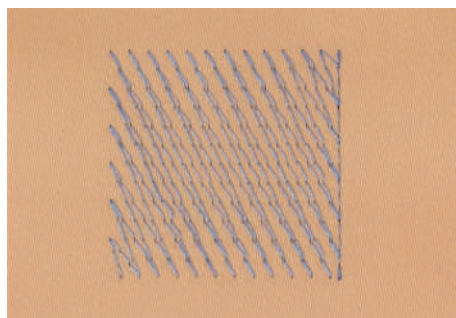

The Size of the Embroidery Design

Embroidery designs can be enlarged or downsized on the embroidery machine or on the PC using the BERNINA Embroidery software (optional accessory). Scaling up/downsizing in a range of +/- 20 % provides the best results.

Satin or Leaf Stich

The needle moves left to right and vice versa. The result is a very dense, covering zig zag stitching to fill the shape. Satin stitching fills are ideal for narrow and small shapes. Satin stitching is, however, not suitable for larger areas, since wide stitches are too loose and do not cover the fabric properly. In addition there is the risk that with too long stitches the threads could catch on something which would damage the embroidery.

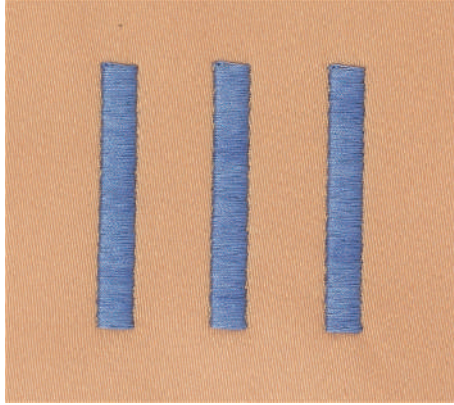

Step Stitch

Many short, equally long stitches are embroidered in offset rows closely next to each other which results in a densely filled area.

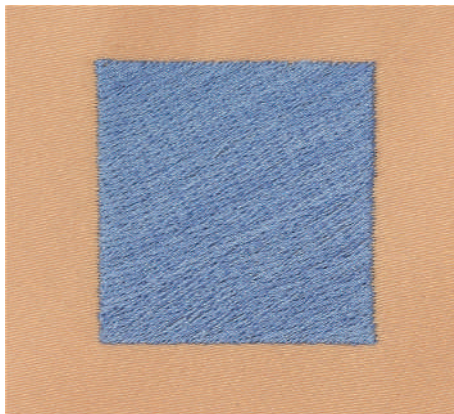

Connecting Stitches

Long stitches which are used to get from one part of the motif to the next. Before and after the connecting stitch securing stitches are sewn. Connecting stitches are trimmed.

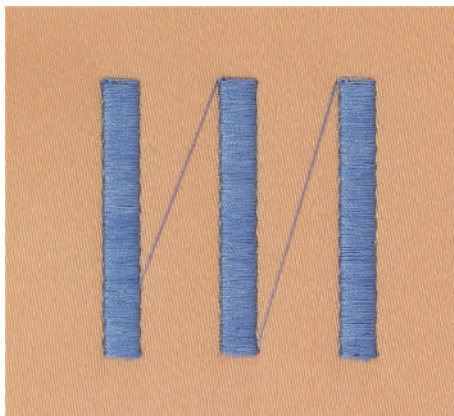

2 Embroidery Preparation

2.1 Connection and Switching On

Connecting the Machine

To ensure safe operation of the machine, only the supplied mains cable may be used. The supplied power cable is designed for the voltage range applicable in the country of use. If the machine is to be used in a country other than the country of origin, the power cable suitable for that country must be obtained from the Authorized bernette dealer.

The power cable for the USA and Canada has a polarized power plug (one contact is wider than the other). To reduce the risk of an electric shock, the plug can only be inserted into the socket in one way. If the power plug does not fit in the socket, reverse then insert the power plug. If the reversed power plug still does not fit, an electrician must install an appropriate socket. Do not modify the power plug in any way.

- > Insert the device connector of the power cable into the machine's power cable connection.



- > Insert the power plug of the power cable into the socket.

Use of the Power Cable (only USA/Canada)

The machine has a polarized plug (one contact is wider than the other). To reduce the risk of electric shock, the plug can only be plugged into the socket in one way. If the plug does not fit into the socket, turn the plug. If it still does not fit, an electrician needs to be called to install an appropriate outlet. Do not modify the plug in any way.

Switching the Machine On

- > Set the power switch to «I».



Fixing the Touch Screen Pen

- > Store the touchscreen pen on the top holder.

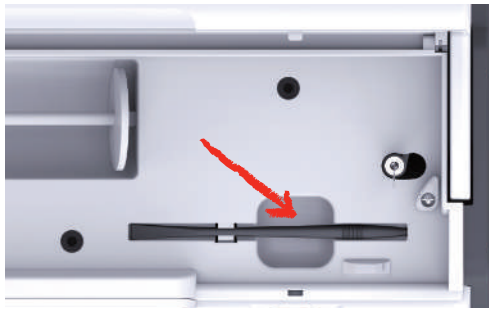

2.2 Spool Pin

Horizontal Spool Pin

Placing the Thread Spool and the Spool Cap

Spool caps hold the thread spool in place for proper release of thread from the spool.

- > Place the thread spool on the spool pin.
- > Position the appropriate spool cap on the spool pin so that there is no space between the spool cap and the thread spool.

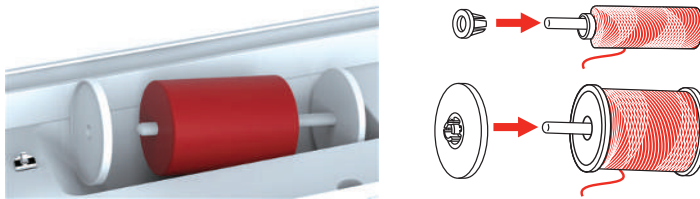

Using the Spool Net

The spool net holds the thread on the thread spool and prevents the thread from knotting and breaking. The spool net is only used with the horizontal spool holder.

- > Pull the spool net over the thread spool. Ensure when doing so that the spool net does not slip off the thread spool, e.g. double-insert the net over the thread spools or insert a part of the net into the thread spool at the rear.

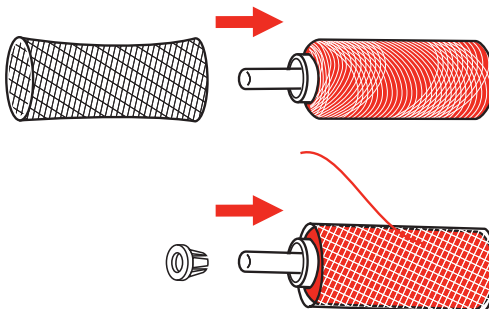

Second Spool Pin

Installing the Second Spool Pin

- > Insert the second spool pin onto the end of the bobbin winding unit (1).
- > Align the notch (2) with the spring (3) on the bobbin winding unit.

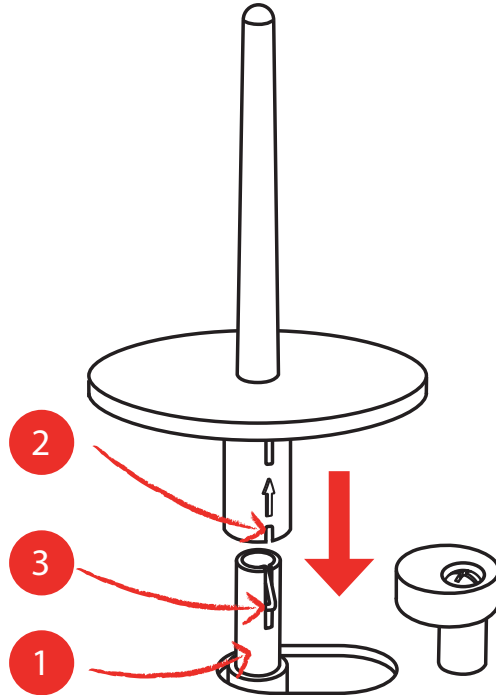

Inserting Thread Spool

The felt disc prevents the thread from sticking to the spool pin.

- > Place the felt disc (1) on the second spool pin.
- > Place the thread spool on the second spool pin.

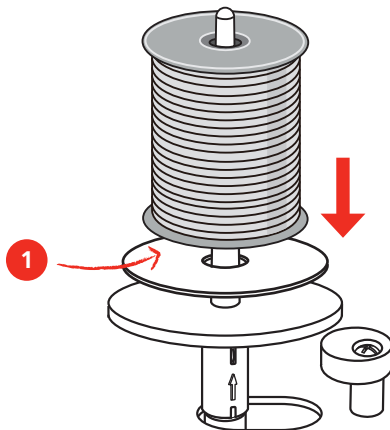

2.3 Attaching the Embroidery Module

NOTICE

Transporting the Embroidery Module

Damage to the embroidery module connection and machine.

> Remove the embroidery module before transporting the machine.

- > Make sure that the module and the machine are placed on a stable, even surface.
- > Ensure that the embroidery arm can move freely.
- > Lift the embroidery module on the left side.
- > Carefully push the module from left to right into the embroidery module connection (1) of the machine so that it engages.



> Hold the embroidery module, press the release button and pull it out.



2.4 Embroidery Foot

Attaching the Embroidery Foot

Mount the Hopper Embroidery Foot

- > Raise the needle.
- > Raise the presser foot.
- > Switch the machine off and disconnect it from the power supply system.
- > Attach the Hopper embroidery Foot (JX) to the presser foot bar, making sure that the spring (3) is over the needle clamp screw (4).
- > Tighten the screw (1).

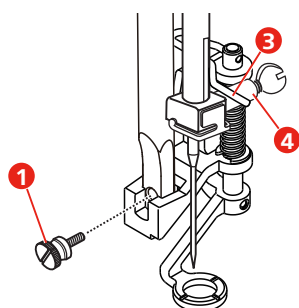

- > After starting the machine, select the embroidery foot in the «Presser Foot Sole Display».

Mount the Embroidery Foot

- > Raise the needle.
- > Raise the presser foot.
- > Switch the machine off and disconnect it from the power supply system.
- > Attach the Embroidery Foot (JL) from the back with the index finger to the presser foot bar and tighten the screw (1).

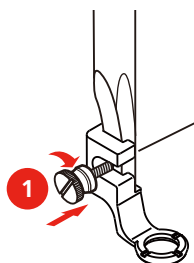

- > **Important:** After starting the machine, select the embroidery foot in the «Presser Foot Sole Display».

Selecting the Embroidery Foot

To ensure that the machine can set the correct standard height for the attached embroidery foot, the embroidery foot must be selected in the «Presser foot sole display».

- > Switch the machine on.
- > Tap «Presser Foot Indicator/Presser Foot Selection».
 - Any presser foot soles are displayed.

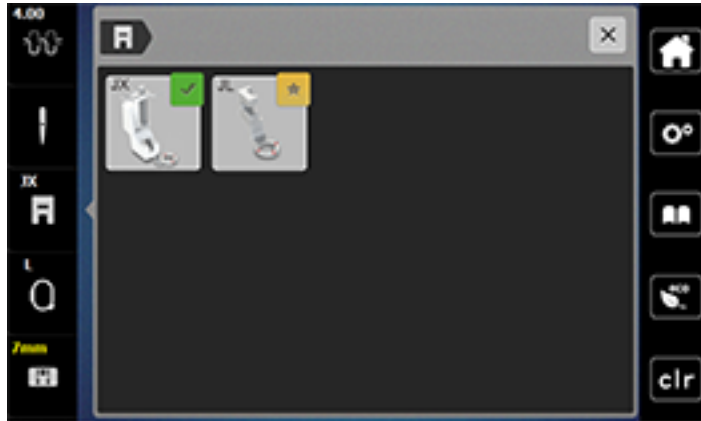

- > Select the attached embroidery foot.
 - A description of the selected embroidery foot is displayed.
- > Tap «Confirm».
 - The selected embroidery foot is displayed and the standard height is set.



2.5 Needle

Inserting the Embroidery Needle



Embroidery needles of the type 130/705 H-SUK provide a larger eye and are slightly rounded. This avoids thread abrasion when using Rayon- and cotton embroidery thread. Depending on the embroidery thread use a size No. 70-SUK to No. 90-SUK needle.

- > Raise the needle.
- > Switch the machine off and disconnect it from the power supply system.
- > Remove the presser foot.
- > Loosen the needle clamp screw (1) using the screwdriver and remove the needle.
- > Hold the needle with the flat side (2) to the back.
- > Push the needle up to the stop (3).
- > Tighten the needle clamp (1) screw using the screwdriver.

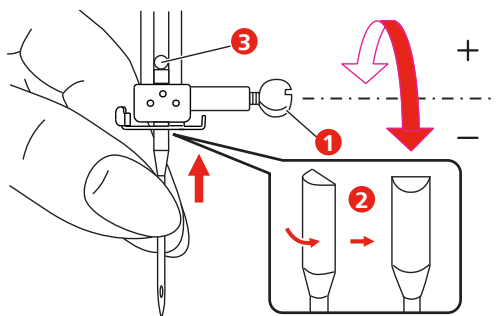

2.6 Threading

Preparing the Threading

- > Press the button «Presser Foot Up/Down » to raise the presser foot.
- > Raise the presser foot.

Threading the Upper Thread

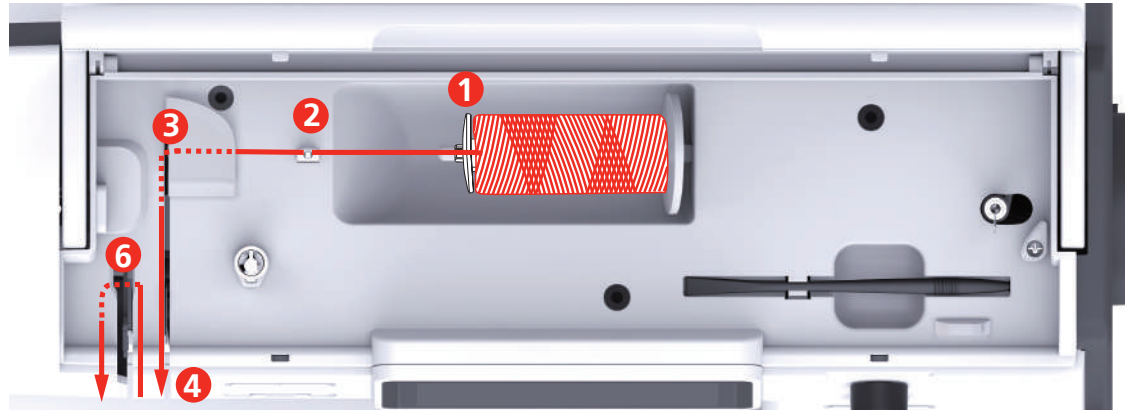

- | | | | |
|---|----------------------------|----|---------------|
| 1 | Spool Cap | 7 | Guide |
| 2 | Thread Guide | 8 | Guide |
| 3 | Thread Pretension | 9 | Thread Lever |
| 4 | Thread Tensions Discs | 10 | Wire Hook |
| 5 | Thread Take-up Lever Cover | 11 | Thread Cutter |
| 6 | Thread Take-up Lever | 12 | Thread |

- > Place the thread spool on the spool pin so that the thread unwinds clockwise.
- > Fit the spool cap suitable for the spool.

- > Feed the thread through the thread guide.

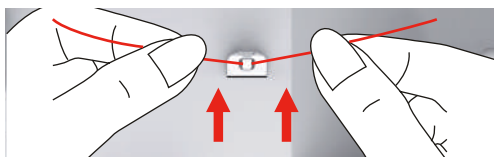

- > Guide the thread through the thread pretension.

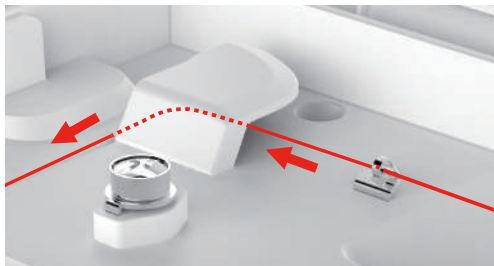

- > Place the end of the thread down along the duct.



- > Guide the thread downwards around the thread take-up lever cover.

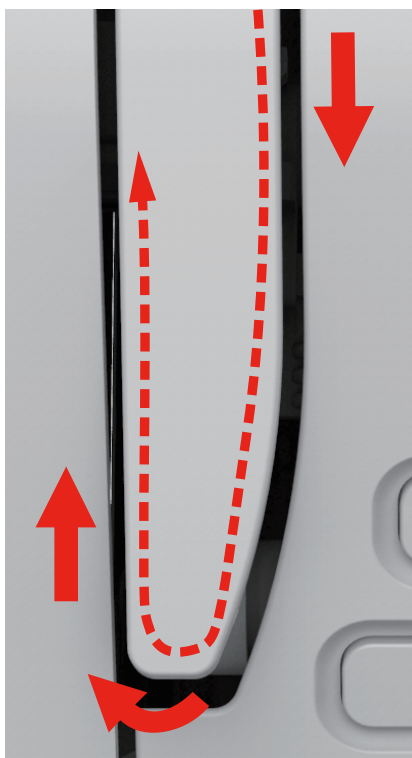

- > Guide the thread at the top from right to the left through the thread take-up lever and then down again.

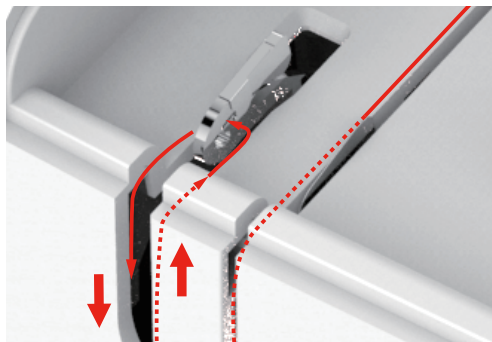

- > Guide the thread through the guides above the needle.
- > Lower the presser foot.

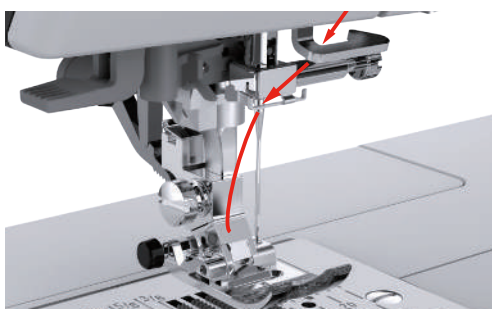

- > Press the threading lever down until it clicks into place.
 - The wire hook goes through the eye of the needle.
 - To prevent damage to the threader, the presser foot is lowered automatically.

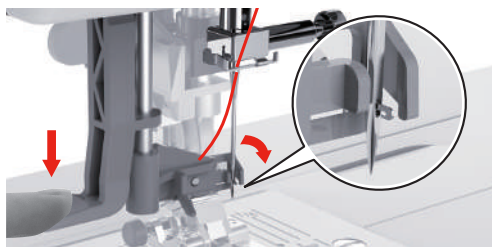

- > Feed the thread around the thread guide.
- > Guide the thread in front of the needle and underneath the wire hook and hold it.

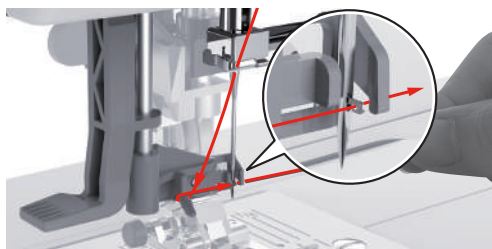

- > To cut off excess thread, take the thread end and carefully pull it over the thread cutter. **Please Note:** Use the right thread cutter only when threading.

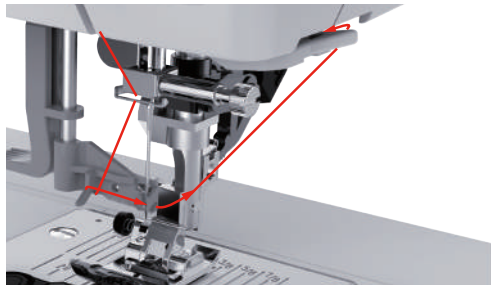
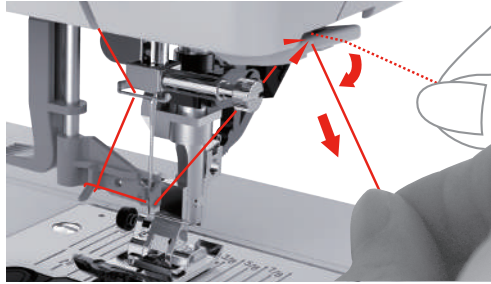

- > To thread the needle, lift the needle-threading lever. Keep the thread loose when doing so.
 - The wire hook moves backwards and pulls the thread through the needle eye into a loop.
- > Pull the thread completely through the eye of the needle.

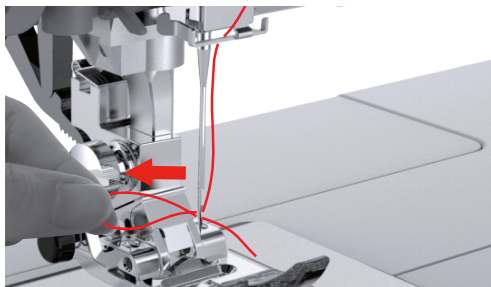

Winding the Bobbin Thread

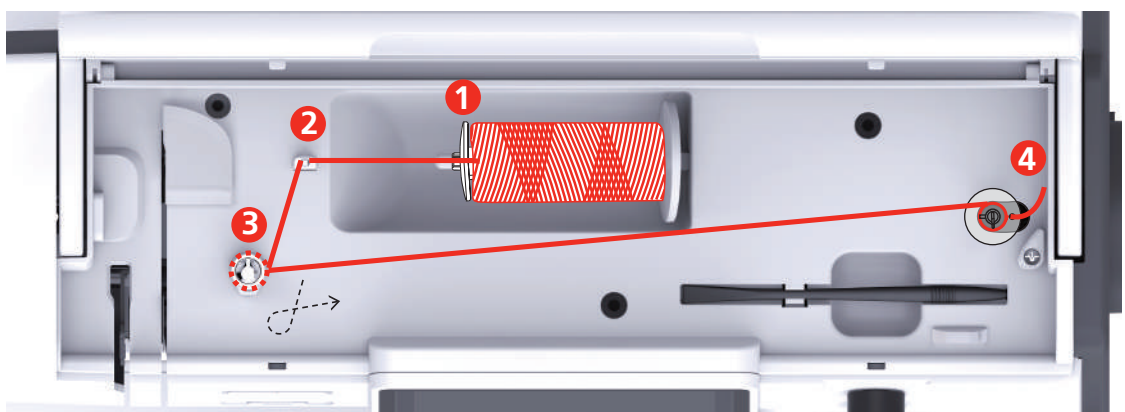

- 1 Spool Cap
- 2 Thread Guide

- 3 Bobbin Winder Pretension
- 4 Spool Pin

- > To prevent slippery threads from catching or breaking, pull the spool net over the spool.

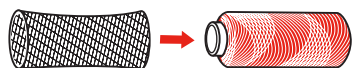

- > Place the thread spool and the appropriate spool cap on the spool holder. Use the small spool cap on the spool holder.

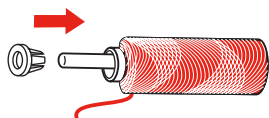

- > Feed the thread through the thread guide.

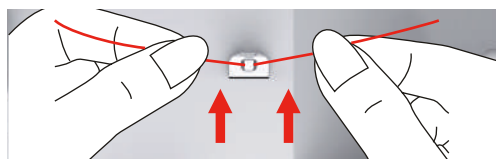

- > Guide the thread around the bobbin winder pre-tension in the direction of the arrow.

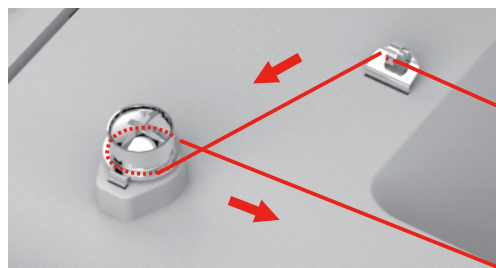

- > Pull the end of the thread through one of the inner holes on the bobbin and place the empty bobbin on the bobbin winding unit.

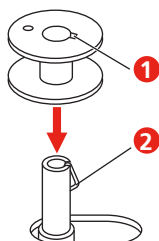

- > Push the bobbin to the right-hand position.

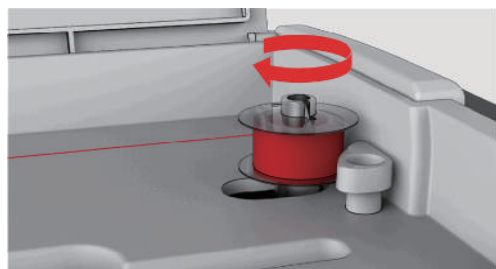

- The button «Start/Stop» flashes and the display for winding appears.

- > Hold the end of the thread tightly with one hand.

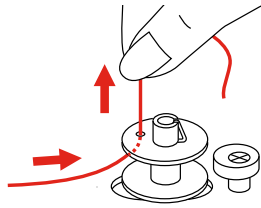

- > To start the winding process for a few rotations and then stop, push the button «Start/Stop», so that the thread is held tight on the bobbin.

- > Cut the end of the thread above the inner hole.

- > To continue the winding process, push the button «Start/Stop».

- > To stop the winding process, push the button «Start/Stop».

- > Push the bobbin winding unit to the left into the starting position.

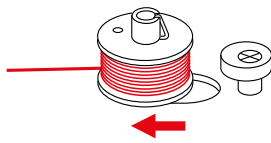

- > Remove the bobbin and cut the thread.

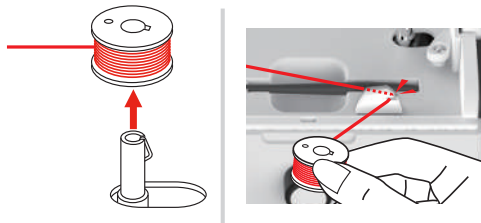

Threading the Bobbin Thread

NOTICE

Needle Breakage Caused by Unevenly Wound Bobbins

Unevenly wound bobbins can lead to incorrect thread tension or cause needles to break.

- > Only use evenly wound bobbins.

Prerequisite:

- The needle is raised.
- The presser foot is raised.
- The machine is switched off.

- > To open the bobbin cover, push the handle to the right and remove the bobbin cover.

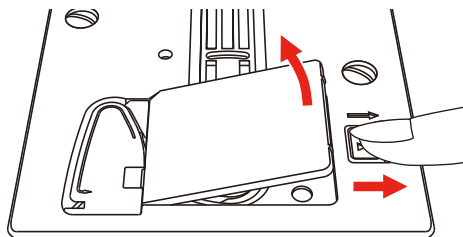

- > Insert a new bobbin so that the thread is wound anti-clockwise.

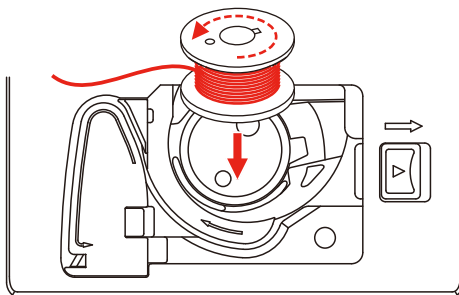

- > Pull the thread into the slit (1).

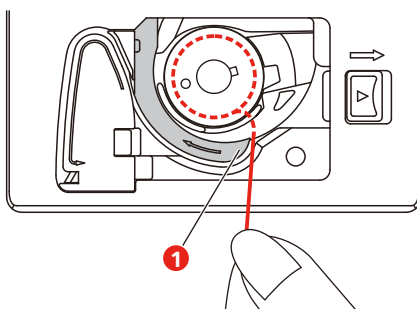

- > Press gently on the bobbin.
- > Follow the arrow markings to bring the thread into the bobbin thread guide.

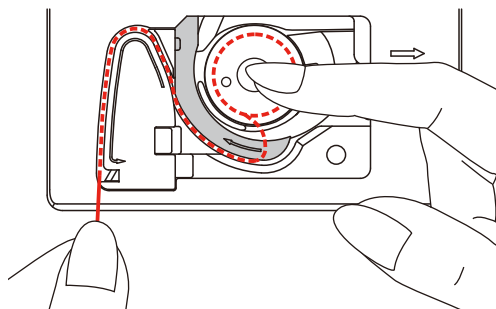

- > To cut off excess thread, take the end of the thread and pull it over the thread cutter (2).

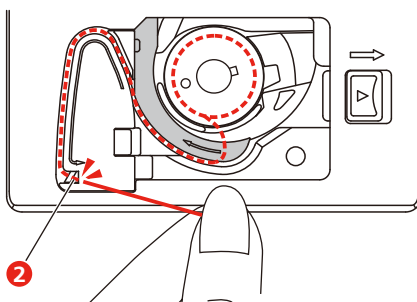

- > Attach the bobbin cover.

2.7 Selecting the embroidery motif

All of the embroidery designs can be either directly embroidered or can be changed using different functions offered by the embroidering machine. You can find all embroidery designs at the end of the instruction manual. In addition to that, embroidery designs can be downloaded from the personal memory or from the USB stick (optional accessory).



- > Tap «Home».
- > Select an alphabet, embroidery design or a personal embroidery design from one of the files.

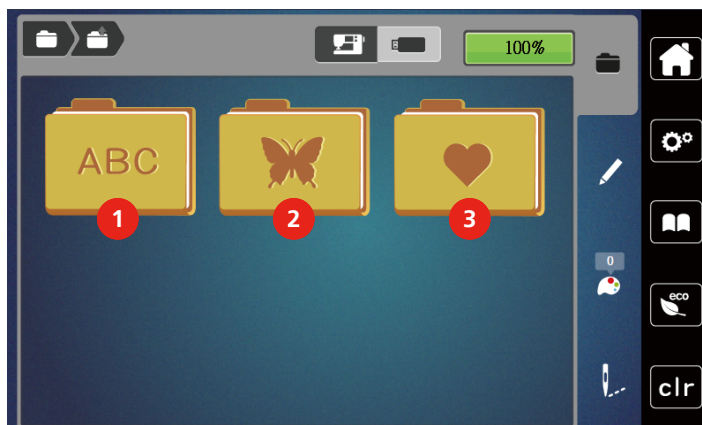

- | | | | |
|---|---------------------|---|----------------------------|
| 1 | Embroidery Alphabet | 3 | Personal Embroidery Design |
| 2 | Embroidery Design | | |

2.8 Embroidery Hoops

Overview Embroidery Hoop Selection

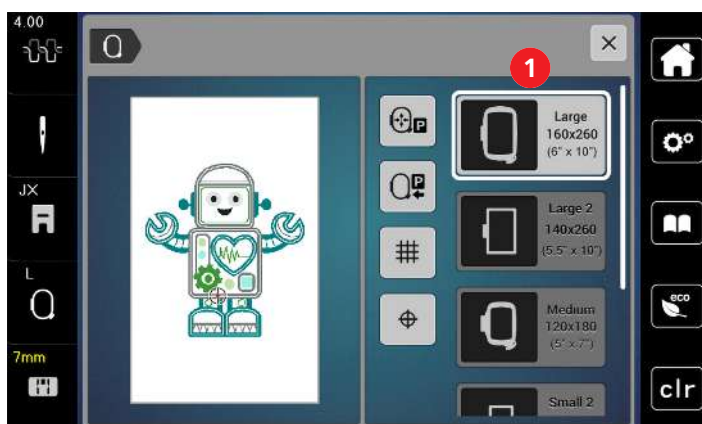

- 1 Hoop Selection

Selecting the Embroidery Hoop

The best embroidery result is achieved when the smallest possible embroidery hoop for the embroidery design is selected.

The embroidery design has a pre-set size which is displayed.

Prerequisite:

- The embroidery design is selected.



- > Tap «Hoop Indicator/Select Hoop».
 - The presently attached embroidery hoop is displayed.
 - The machine selects the optimal embroidery hoop according to the size of the embroidery design automatically.
 - If the preset embroidery hoop is not available, another desired embroidery hoop can be selected.
 - When an embroidery hoop is attached which does not correspond with the selected one, the attached hoop is considered active and the embroidery design area is displayed accordingly.
- > Select the desired embroidery hoop.

Tear-away Stabilizers

Using a stabilizer ensure more stability of the embroidery project. A tear-away stabilizer suits all woven and non-stretch materials. 1 – 2 layers can be used. Stabilizers are available in different weights. With larger areas to be embroidered the stabilizer will remain under the embroidery thread. The stabilizer is applied to the wrong side of the fabric with temporary adhesive spray. Carefully cut away excess stabilizer after embroidering.

Cut-away Stabilizers

Using a stabilizer ensure more stability of the embroidery project. A cut-away stabilizer suits all elastic materials. 1 – 2 layers can be used. Stabilizers are available in different weights. With larger areas to be embroidered the stabilizer will remain under the embroidery thread. The stabilizer is applied to the wrong side of the fabric with temporary adhesive spray. Carefully cut away excess stabilizer after embroidering.

Using Adhesive Spray

The application of spray adhesive is recommended for stretch and smooth materials and knitware. It prevents the fabric from losing shape and slipping. Appliqués can be exactly positioned with spray adhesive. The spray adhesive shouldn't be used near the machine to avoid contamination.

- > Use the spray adhesive carefully at a distance 25 – 30 cm (9 – 12 inch) when spraying the stabilizer.
- > Adhere the sprayed stabilizer to the wrong side of the fabric carefully, smoothing material so there are no puckers.
- > Position smaller parts such as pocket flaps or collars on the stabilizer.
- > To avoid the possibility of getting hoop marks when working with napped materials or fleece, don't hoop the parts but spray the stabilizer and hoop it.
- > Adhere the fabric to be embroidered.
- > Remove any adhesive residue before starting the machine.

Using Spray Starch

Spray starch is ideal for additional stiffening fine, loosely woven materials. Always use an additional stabilizer on the wrong side of the material.

- > Spray the area to be embroidered.
- > Let it dry or press gently with a warm iron if necessary.

Using Iron-on Interfacing

Iron-on interfacings are available in a variety of weights. It is recommended to use an iron-on interfacing which is easily removable from the basic fabric. An Iron-on interfacing suits all materials that are easily distorted like stretch fabric such as tricot and jersey.

- > Iron-on interfacings are ironed to the wrong side of the material using a warm iron.

Using Paper-backed Adhesive Stabilizer

Paper-backed adhesive stabilizers are intended to be used for fabrics such as jersey and silk as well as for embroidery projects which are not suited to be hooped in the embroidery hoop.

- > Place the stabilizer in the hoop, so that the paper side is up.
- > Use a pair of scissors to score the paper and remove paper in the hoop area.
- > Position the fabric to be embroidered on the stabilizer and press it on place.
- > Remove any adhesive residue before starting the machine.

Using Water-soluble Stabilizer



For lace embroidery it is recommended to hoop 1 - 3 layers of water-soluble stabilizer in the embroidery hoop. As the embroidery design is not embroidered on the fabric, only the thread embroidered design is left. The embroidery designs should be combined with short stitches otherwise the individual designs may fall out.

Water-soluble stabilizers are ideal for fine, sheer fabrics where other stabilizers may show through the embroidery stitches as well as for lace embroidery. The stabilizer dissolves in water. Water-soluble stabilizers are an ideal protection for looped pile fabrics preventing the loops from being damaged. It prevents threads from sinking into the material and keeps the fabric pile from poking through the embroidery.

- > Place the stabilizer on the underside of the material.
- > Use adhesive spray to adhere stabilizer if necessary.
- > For material with a pile, reinforce with additional, suitable stabilizer on the wrong side.
- > Place all the layers together into the embroidery hoop.
- > After dissolving, lay the motif down flat and let dry.

Preparing the Embroidery Hoop

The embroidery hoop consists of an outer and an inner hoop. There is a corresponding template for every hoop. The area to be embroidered is marked in 1 cm (0.39 in) squares. The center is marked with hole and cross lines. The required marks can be transferred to the material.

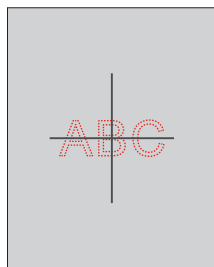

- > Loosen the screw (1) or open the quick release device (2) on the outer hoop.
 - If a new type of fabric is used, the pressure must be adjusted by turning the screw.

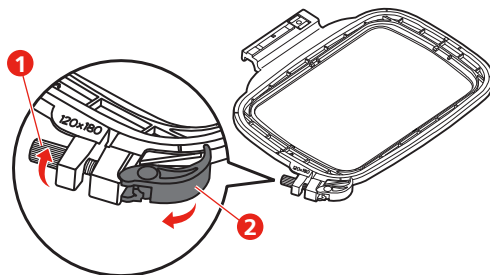

- > Remove the inner hoop.

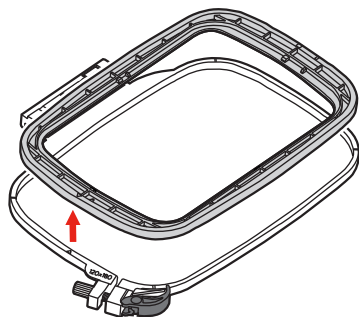

- > Place the template (1) in the inner hoop, so that the bernette logo is aligned with the arrow marking at the front edge so that it clicks into place.

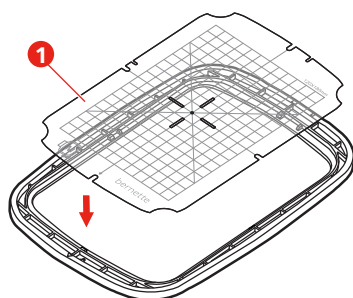

- > Place fabric under the inner frame so that it is at least 2 cm above the hoop.
- > Align the center of the embroidery design with the center of the template.
- > Place the material and the inner hoop on the outer hoop, so that the arrow markings of both hoops are aligned.

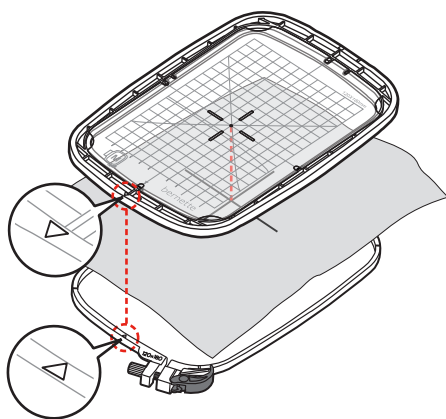

- > Fit the hoops into each other so that the material does not move.
- > Hoop the fabric tautly in the embroidery hoop.
- > Close the quick release device (2). If necessary, tighten screw (1).
- > The inner hoop should protrude about 1 mm on the underside, this prevents the hoop from sticking to the stitch plate.
- > The quick release device (2) is for changing the same type (thickness) fabric easily and quickly.

- > Remove the template (3) from the hoop.

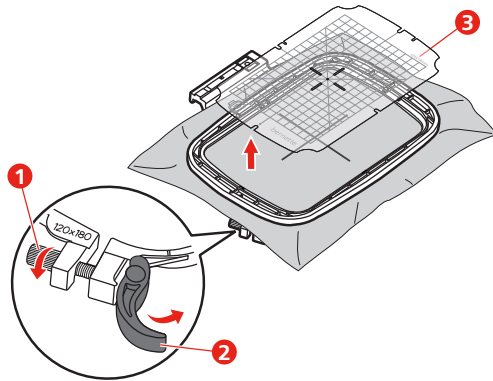

Attaching the Hoop

- > Raise the needle.
- > Raise the embroidery foot.
- > Position the hoop below the embroidery foot.
- > Push the embroidery hoop into the embroidery module until it clicks into place.
 - The hoop is attached.

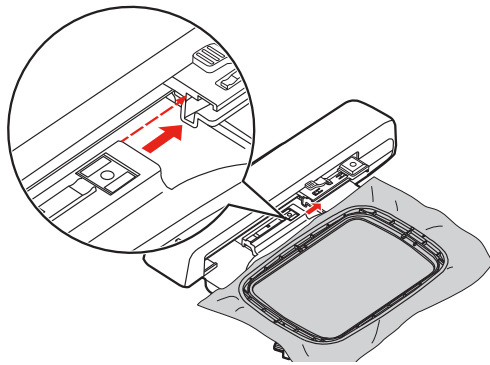

- > To remove the hoop, press the securing lever and pull the hoop backwards.

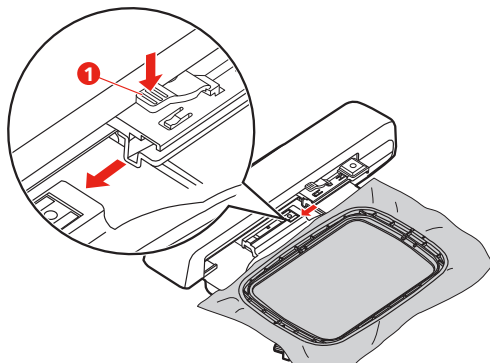

Overview Embroidery Functions

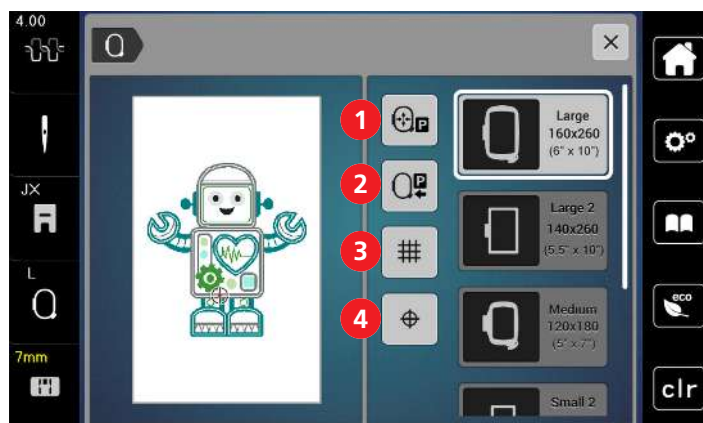

- | | | | |
|---|---|---|-----------------------------|
| 1 | Centering the Needle to the Embroidery Hoop | 3 | Grid On/Off |
| 2 | Embroidery Arm Return | 4 | Center of Embroidery Design |

Locating the Center of the Embroidery Design

The embroidery hoop is positioned so that the needle is exactly above the center of the embroidery design or the motif begin.



- > Tap «Hoop Indicator/Select Hoop».



- > To position the hoop so that the needle is placed exactly over the center of the embroidery design, tap «Center of Embroidery Design».
- > To position the hoop so that the needle is placed exactly over the motif start, tap «Center of Embroidery Design» again.

Centering the Needle to the Embroidery Hoop

Relocating the embroidery hoop facilitates threading when the needle is close to the embroidery hoop.



- > Tap «Hoop Indicator/Select Hoop».



- > To move the embroidery hoop to the middle, tap «Center the Needle to the Embroidery Hoop».
- > Thread the upper thread.



- > To move the hoop back to its previous position, push the button «Start/Stop».

Embroidery Arm Return

The embroidery arm can be positioned for storage the embroidery module.



- > Tap «Hoop Indicator/Select Hoop».
- > Remove the embroidery hoop.



- > To move the embroidery arm horizontally to the left, tap «Move Hoop to the Left».



- > To move the embroidery arm back to its previous position, press the «Start/Stop» button.

Grid On/Off

When the center of the hoop and the grid are displayed, the embroidery design can be positioned more exactly.



- > Tap «Hoop Indicator/Select Hoop».



- > To show the hoop center on the display, tap «Grid On/Off».
- > To show the grid lines, tap «Grid On/Off» again.
- > To hide the hoop center and the grid lines, tap «Grid On/Off» again.

3 Setup Program

3.1 Embroidery Settings

Adjusting the Upper Thread Tension

Changes to the upper thread tension in the Setup Program affect all of the embroidery designs.



> Tap «Setup Program».



> Tap «Embroidery Settings».



> Tap «Adjusting the Upper Thread Tension».
> Adjust the upper thread tension.

Adjusting the Maximum Embroidering Speed

The maximum speed can be reduced by this function.



> Tap «Setup Program».



> Tap «Embroidery Settings».



> Tap «Maximum Embroidering Speed».
> Set the maximum sewing speed.

Calibrating the Embroidery Hoop

The calibration of the embroidery hoop is the coordination of the needle to the center of the embroidery hoop.

Prerequisite:

- The embroidery module is connected and the embroidery hoop with the appropriate embroidery template is attached.



> Tap «Setup Program».



> Tap «Embroidery Settings».



> Tap «Calibrating the Embroidery Hoop».
– The machine recognizes the size of the attached embroidery hoop automatically and moves to the center of the hoop.

- > Center the needle via the arrow icons on the display and confirm.

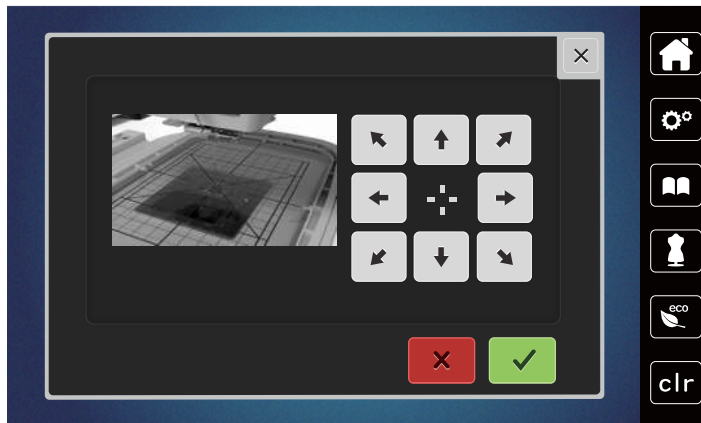

Deactivating Securing Stitches



- > Tap «Setup Program».



- > Tap «Embroidery Settings».



- > Tap «Securing Stitches On/Off».
- > Tap the switch in the lower left area to deactivate the securing stitches.
 - No securing stitches will be sewn and the bobbin thread needs to be brought up manually and held when embroidering is started.
- > Tap the switch again to activate the securing stitches.

Adjusting the Thread Cut



- > Tap «Setup Program».



- > Tap «Embroidery Settings».



- > Tap «Thread Cut Settings».



- > To deactivate the automatic thread cut before changing a thread, tap the switch in the upper section of the display (1).
- > To activate the automatic thread cut before changing a thread, tap the switch in the upper section of the display (1) again.
- > To deactivate the manual thread cut after embroidering, tap the switch in the lower section of the display (2).
 - The machine won't stop for a manual thread cut.
- > To activate the manual thread cut after embroidering, tap the switch in the lower section of the display (2).
 - The machine will stop after about 7 stitches.

- > Cut the remaining thread with scissors.

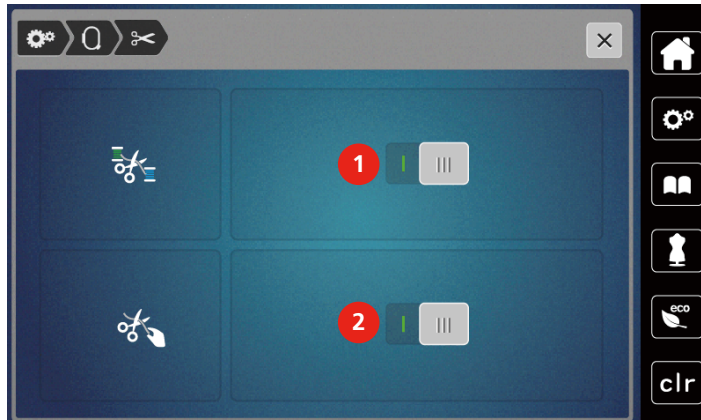

Adjusting the Height of the Embroidery Presser Foot



- > Tap «Setup Program».



- > Tap «Embroidery Settings».



- > Tap «Entering the Fabric Thickness».
- > To set the distance between the embroidery foot and the stitch plate, turn the «Upper Multi-function Knob» or «Lower Multi-function Knob», or tap «Plus» or «Minus».

3.2 Selecting Personal Settings



- > Tap «Setup Program».



- > Tap «Personal Settings».
- > Select the desired display color.



3.3 Monitoring Functions

Activating the Upper Thread Indicator



- > Tap «Setup Program».



- > Tap «Monitoring Functions».



- > Tap the switch in the upper section of the display to deactivate the upper thread indicator.
- > Tap the switch again to activate the upper thread indicator.

Activating the Bobbin Thread Indicator



- > Tap «Setup Program».



- > Tap «Monitoring Functions».



- > Tap the switch in the lower section of the display to deactivate the bobbin thread indicator.
- > Tap the switch again to activate the bobbin thread indicator.

3.4 Sound On/Off



- > Tap «Setup Program».



- > To switch off all sounds, tap «Switching Sounds On/Off».
- > To switch on all sounds, tap «Switching Sounds On/Off» again.

3.5 Machine Settings

Adjusting the Brightness of the Display

The brightness of the display can be set to meet your individual needs.



- > Tap «Setup Program».



- > Tap «Machine Settings».



- > Tap «Display Settings».
- > Adjust the brightness of the display in the upper section of the screen.

Calibrating the Display

Please find further information on this topic in the chapter attachment below troubleshooting at the end of the instruction manual.



> Tap «Setup Program».



> Tap «Machine Settings».



> Tap «Calibrating the Screen».

> Touch the crosses in sequence using the touchscreen pen.

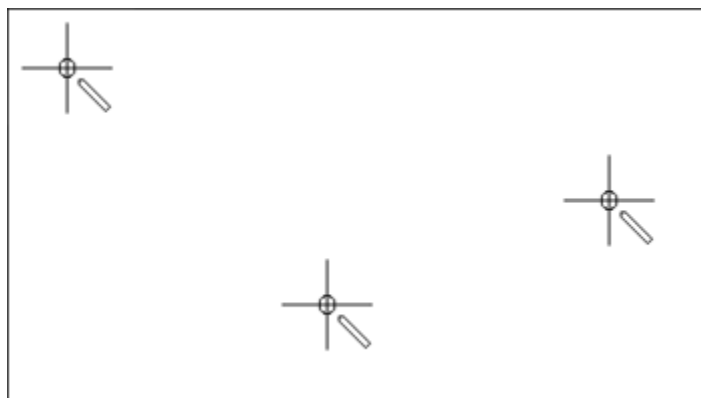

Back to basic setting

CAUTION: Using this function will delete all individually made settings.



> Tap «Setup Program».



> Tap «Machine Settings».



> Tap «Factory Setting».



> Tap the «Default Setting Embroidering», confirm and start the machine again.

Updating the Machine Firmware

The machine's current firmware and detailed step-by-step instructions for the update process can be downloaded from <https://www.bernette.com> Personal data and settings are automatically transferred during a firmware update.

NOTICE

USB Stick (Optional Accessory) has been Removed too Early

Firmware has not been updated and the machine cannot be used.

> Remove the USB stick (Optional accessory) only after the saved data has been transferred successfully.

> Insert the BERNINA USB Stick (optional accessory), FAT32 formatted, providing the latest software into the port.

> Tap «Setup Program».



> Tap «Machine Settings».



> Tap «Machine Data».



UPDATE

> To update the machine firmware, tap «Update».

Checking the Firmware Version

The firmware version of the machine is displayed.

> Tap «Setup Program».



> Tap «Machine Settings».



> Tap «Machine Data».



Reviewing the Total Number of Stitches

The total stitch count of the machine and the number of stitches since the last service performed by a bernette dealer are displayed.

Four million stitches after a service, the symbol  recommends maintenance by specialized bernette dealer.



> Tap «Setup Program».



> Tap «Machine Settings».



> Tap «Machine Data».

Selecting a Language

The user interface can be programmed in different languages according to the customer's wish.



> Tap «Setup Program».



> Tap «Machine Settings».



> Tap «Language Selection».
> Select a language.

4 System Settings

4.1 Calling up the tutorial

The Tutorial gives information and explanations concerning various aspects of embroidering.



- > Tap «Tutorial».
- > Select the desired topic in order to view information.

4.2 Using eco Mode

If work is interrupted for an extended period, the machine can be put into energy-saving mode. Nothing can be selected in the display and the machine cannot be started.



- > Tap «eco Mode».
 - The display goes to sleep. The power consumption is reduced and the sewing light is off.

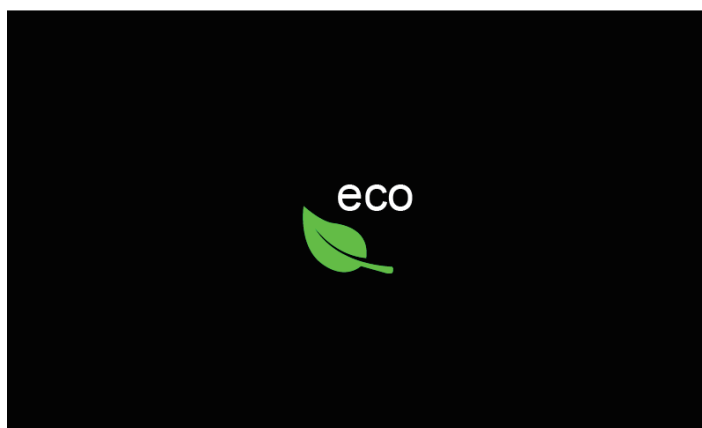

- > Tap «Eco mode» in the display.
 - The machine is ready for use.

4.3 Cancelling Any Alterations with «clr»

Any alterations to designs can be reset to basic setting. Exceptions are saved designs which have been filed in the personal memory and monitoring functions.



- > Tap «Clear Settings».

5 Creative Embroidering

5.1 Overview Embroidering

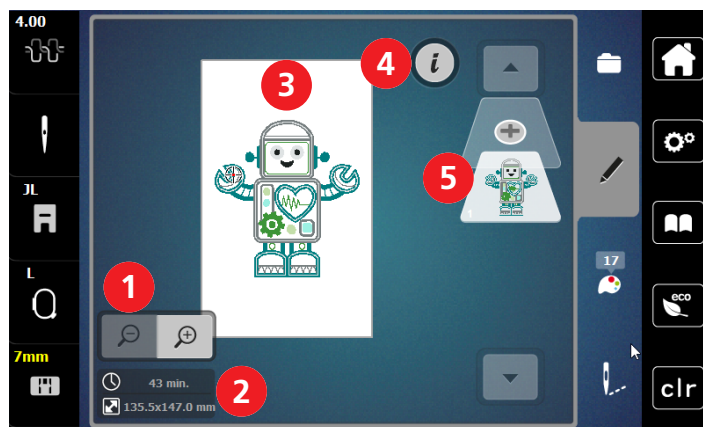

- | | |
|---|--|
| <p>1 Scaling up, Downsizing and Moving the Embroidery Design View</p> <p>2 Embroidery Time/Embroidery Design Size in mm</p> <p>3 Area to be Embroidered</p> | <p>4 i-Dialog</p> <p>5 Adding an Embroidery Design Layer</p> |
|---|--|

Selecting and Changing the Embroidery Design



- > Tap «Selection».



- > Tap «Loading the Embroidery Design».
- > Select a new embroidery design.

Overview Editing Embroidery Design

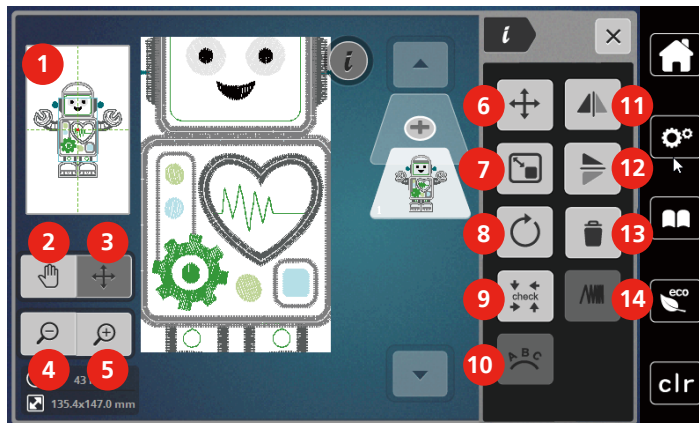

- | | | | |
|---|---|----|--------------------------------|
| 1 | Preview all | 8 | Rotating the Embroidery Design |
| 2 | Move View | 9 | Check Embroidery Design Size |
| 3 | Moving the View of the Design | 10 | Bending the Text |
| 4 | Zoom Out | 11 | Mirror Image Left/Right |
| 5 | Zoom In | 12 | Mirror Image Up/Down |
| 6 | Moving the Embroidery Design | 13 | Deleting |
| 7 | Altering the embroidery design proportionally | 14 | Altering the Stitch Density |

Moving the Embroidery Design

- > Select the embroidery design.
- > Tap «i-Dialog».



- > Tap «Move the Embroidery Design».
- > Turn the «Upper Multi-function Knob» to move the embroidery design horizontally.
- > Turn the «Lower Multifunction knob» to move the embroidery design vertically in 0.5-mm steps or touch the «+»/«-» icon or touch the embroidery design, keep it pressed and move it as you like.
 - The relocation is indicated in the yellow-outlined icons.

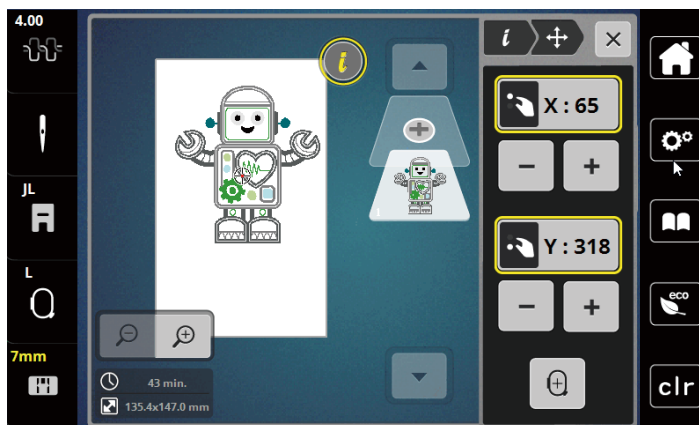

- > Tap «Center of Embroidery Design».
- The embroidery design is repositioned in the center of the embroidery hoop.

5.2 Selecting and Changing the Embroidery Design



> Tap «Selection».



> Tap «Loading the Embroidery Design».

> Select a new embroidery design.

5.3 Checking the Embroidery Time and the Embroidery Design Size

In the selection menu «Edit» the estimated embroidery time in minutes as well as the width and height of the embroidery design is indicated at lower left (1).

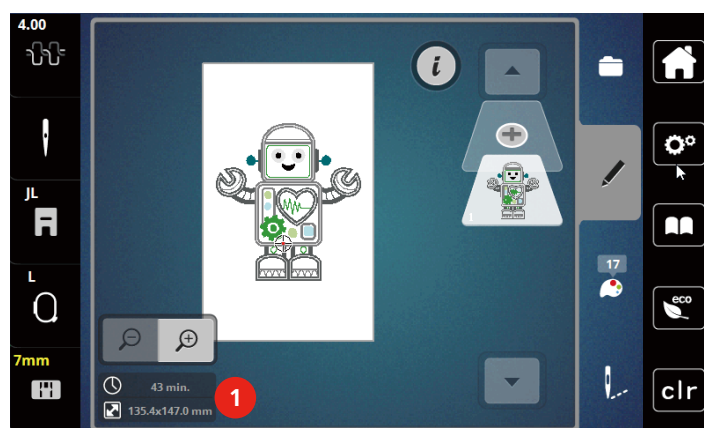

5.4 Regulating the Speed

The sewing speed can be adjusted infinitely variable with the slide.

> Move the slide to the left to reduce the sewing speed.

> Move the slide to the right to increase the sewing speed.

5.5 Editing the Embroidery Design

Overview Editing Embroidery Design

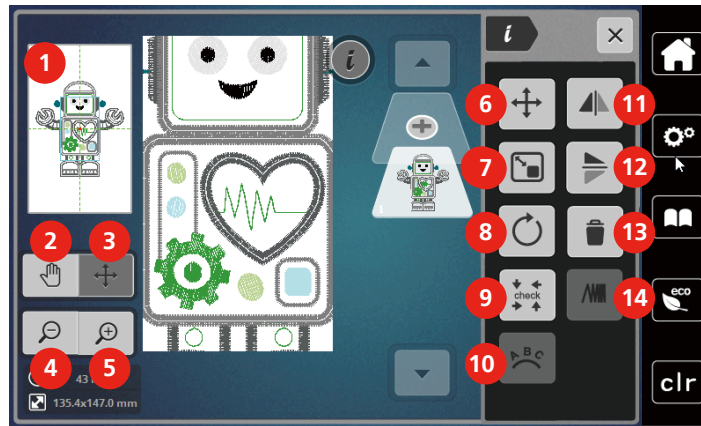

- | | | | |
|---|---|----|--------------------------------|
| 1 | Preview all | 8 | Rotating the Embroidery Design |
| 2 | Move View | 9 | Check Embroidery Design Size |
| 3 | Moving the View of the Design | 10 | Bending the Text |
| 4 | Zoom Out | 11 | Mirror Image Left/Right |
| 5 | Zoom In | 12 | Mirror Image Up/Down |
| 6 | Moving the Embroidery Design | 13 | Deleting |
| 7 | Altering the embroidery design proportionally | 14 | Altering the Stitch Density |

Scaling Up the Embroidery Design View

The view of the embroidery design can be scaled up. In addition to that, the view can be adjusted with or without changing the embroidery position.

- > Select the embroidery design.
- > To edit the view of the embroidery design, tap «Zoom In».



- > To increase the embroidery design view by one level each time, tap «Zoom In» one to nine times.



- > To return to editing mode, tap «Zoom Out» one to nine times.

Downsizing the Embroidery Design

The view of the embroidery design can be downsized. In addition to that, the view can be adjusted with or without changing the embroidery position.

- > Select the embroidery design.
- > To enlarge the view of the embroidery design, tap «Zoom In».



- > To minimize the enlarged embroidery design view by one level each time, tap «Zoom Out» one to nine times.

Moving the embroidery design view

The view of the embroidery design can be moved. In addition to that, the embroidery design position won't be changed.

- > Select the embroidery design.
- > To edit the view of the embroidery design, tap «Zoom In».



- > Tap «Move View».
- The icon turns dark gray.
- > Alter the view of the embroidery design.
- The embroidery position is not altered.



- > To return to the previous view, tap «Zoom Out».



Moving the embroidery design in enlarged view

The view of the embroidery design can be moved when the embroidery position is changed.

- > Select the embroidery design.
- > To activate «Move the Embroidery Design», tap «Zoom In».



- > Tap «Move the Embroidery Design».
- The icon turns dark gray.
- > Moving the embroidery design.
- The embroidery design position is altered.



- > To return to the previous view, tap «Zoom Out» again.



Moving the Embroidery Design

- > Select the embroidery design.
- > Tap «i-Dialog».



- > Tap «Move the Embroidery Design».
- > Turn the «Upper Multi-function Knob» to move the embroidery design horizontally.
- > Turn the «Lower Multifunction knob» to move the embroidery design vertically in 0.5-mm steps or touch the «+»/«-» icon or touch the embroidery design, keep it pressed and move it as you like.
- The relocation is indicated in the yellow-outlined icons.

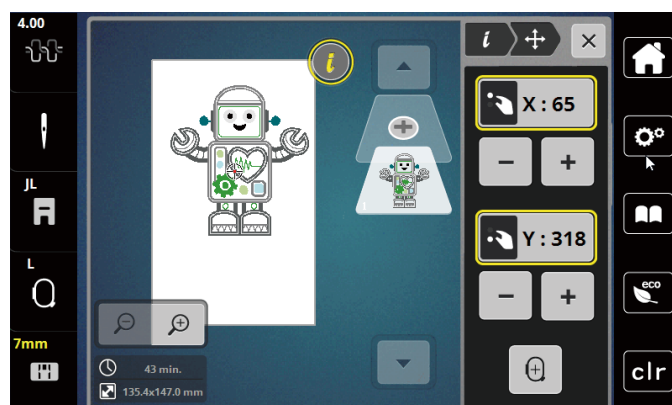



- > Tap «Center of Embroidery Design».
- The embroidery design is repositioned in the center of the embroidery hoop.

Rotating the Embroidery Design



- > Select the embroidery design.
- > Tap «i-Dialog».



- > Tap «Rotate the Embroidery Design».
- > To rotate the embroidery design clockwise, turn the «Upper Multi-function Knob» or «Lower Multi-function Knob» to the right, or tap «Plus».
- > To rotate the embroidery design counterclockwise, turn the «Upper Multi-function Knob» or «Lower Multi-function Knob» to the left, or tap «Minus».



- > To rotate the embroidery design in 90°-steps, tap «Rotate the Embroidery Design +90°».

Altering the Embroidery Design Size Proportionally

The alteration is limited to +/- 20%.



- > Select the embroidery design.
- > Tap «i-Dialog».



- > Tap «Change Design Size».
- > To enlarge the embroidery design in proportion, turn the «Upper Multi-function Knob» or «Lower Multi-function Knob» to the right, or tap «Plus».
- > To minimize the embroidery design in proportion, turn the «Upper Multi-function Knob» or «Lower Multi-function Knob» to the left, or tap «Minus».

Mirroring Embroidery Designs

Embroidery designs can be mirror-imaged both vertically and horizontally.



- > Select the embroidery design.
- > Tap «i-Dialog».



- > To mirror-image the embroidery design vertically/perpendicular, tap «Mirror Image Left/Right».



- > To mirror-image the embroidery design horizontally/across, tap «Mirror Image Up/Down».

Checking the Size and the Position of the Embroidery Design

It can be checked whether or not the embroidery design matches the designated position/location on the fabric.

- > Select the embroidery design.
- > Tap «i-Dialog».



- > Tap «Check Embroidery Design Size».
 - The embroidery hoop travels all the way until the needle is at the position as it is indicated in the display.
 - If the embroidery design hasn't been positioned correctly yet, the position can be altered via the «Upper/Lower Multi-function Knobs» and the complete embroidery positions can be checked again.

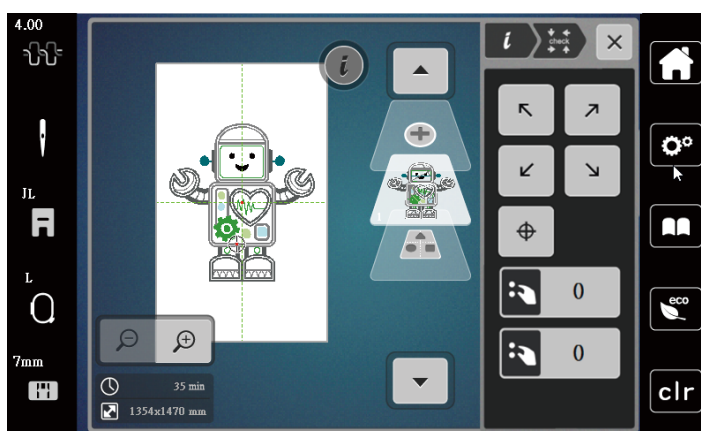

- > To position the needle in the center of the embroidery design, tap «Center of Embroidery Design».
- > Turn the «Upper Multi-function Knob» to move the embroidery design horizontally.
- > Turn the «Lower Multi-function Knob »to move the embroidery design vertically.

Deleting an Embroidery Design

The active embroidery design is deleted.

- > Select the embroidery design.
- > Tap «i-Dialog».



- > Tap «Deleting».



- > To delete the embroidery design, tap «Confirm».

5.6 Creating Lettering

Overview Embroidery Alphabets

Embroidery Design	Name
ABC	Swiss Block
A B C	Swiss Block vertical
ABC	Childs Play
A B C	Childs Play vertical
ABC	Victoria
ABC	Anniversary
أ ب ت	Arabic
А Б В	Cyrillic
א ב ג	Hebrew

Creating Words/Sentences

Lettering can be positioned within the hoop as you like. When the embroidery design is positioned outside the area to be embroidered, the hoop is outlined in red on the display. With the Hoop Selection, it can be checked whether or not the embroidery design can be embroidered in another hoop. When the lettering does not fit in any hoop, two single words can be combined and positioned below each other as the following example will show.



- > Select the «Alphabets» folder.
- > Select the font.
- > Enter the text «Made to».
- > To use large font, tap «Upper Case Characters» (1) (standard setting).
- > To use small font, tap «Lower Case Characters» (2).
- > To use numbers and mathematical characters, tap «Numbers and Mathematical Characters» (3).

- > To use special characters, tap «Special Characters» (4).



- > To delete single letters of the entered text, tap «Deleting».



- > To accept the text, tap «Confirm».



- > Tap «Hoop Indicator/Select Hoop».
- > Select the hoop.
- > To return to editing mode, tap «Hoop Indicator/Select Hoop» again.

Editing Words/Sentences



- > Tap «i-Dialog».



- > Tap «Rotate the Embroidery Design».



- > To rotate the text by 90°, tap «Rotate the Embroidery Design +90°».
- > Tap «i» (1).



- > Tap «Move the Design».
- > Turn the «Upper Multi-function Knob» to move the embroidery design horizontally or tap «Plus»/«Minus».
- > Turn the «Lower Multi-function Knob» to move the embroidery design vertically or tap «Plus»/«Minus».

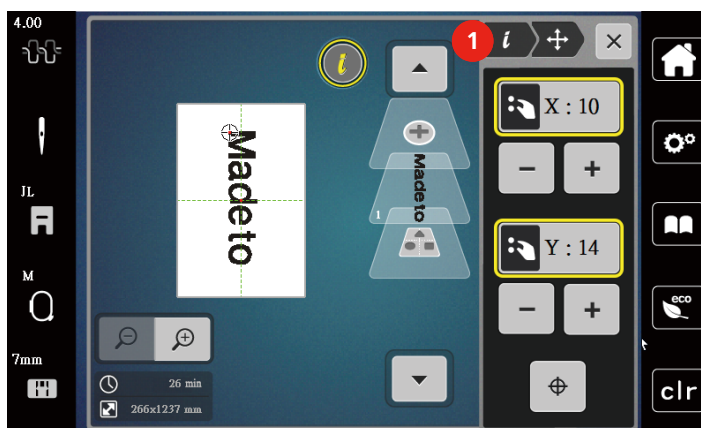



- > Tap «Adding an Embroidery Design».
- > Enter and also rotate the text «create».



- > Tap «Hoop Indicator/Select Hoop».



- > To position the text lines more precisely, tap «Grid On/Off».

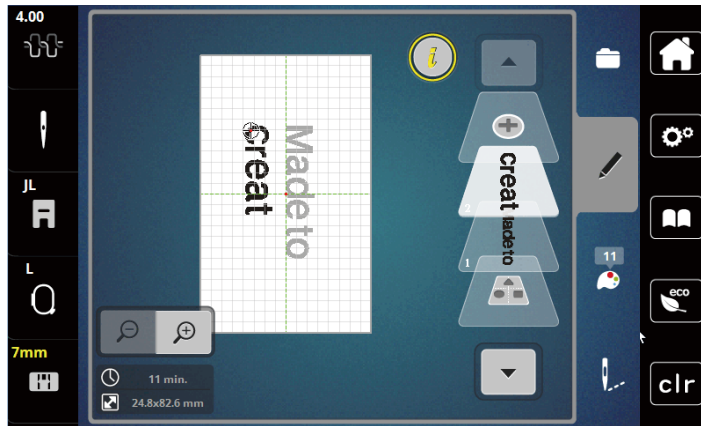

Bending the Text

Texts can be arranged and designed arc-shaped. This function is only applicable to alphabets.

- > Select an alphabet embroidery design.
- > Tap «i-Dialog».



- > Tap «Word Art».
- > To change the distance between the characters in increments of one millimeter, turn the «Upper Multi-function Knob» or tap «Plus»/«Minus».
- > Turn the «Lower Multi-function Knob» to the left or right to curve the writing upward or downward, or tap «Plus»/«Minus».

Altering the Stitch Density

- > Select the embroidery design. This function is only applicable to alphabets.
- > Select an alphabet embroidery design.
- > Tap «i-Dialog».



- > Tap «Alter Stitch Type/Stitch Density».
- > To set the desired stitch density, tap the «Percent» field.

5.7 Combining Embroidery Designs

Combining Embroidery Designs



- > Select the embroidery design.
- > Tap «Adding an Embroidery Design» (1).
- > Select another embroidery design.
- > To select whole embroidery designs, tap «Select all Embroidery Designs».
 - The size of the combination cannot be adjusted.

Deleting a Single Embroidery Design



- > Select the embroidery design which is to be deleted.
- > Tap «i-Dialog».



- > Tap «Deleting».



- > Tap «Confirm».

5.8 Changing the Colors of the Embroidery Design

Overview Changing the Color

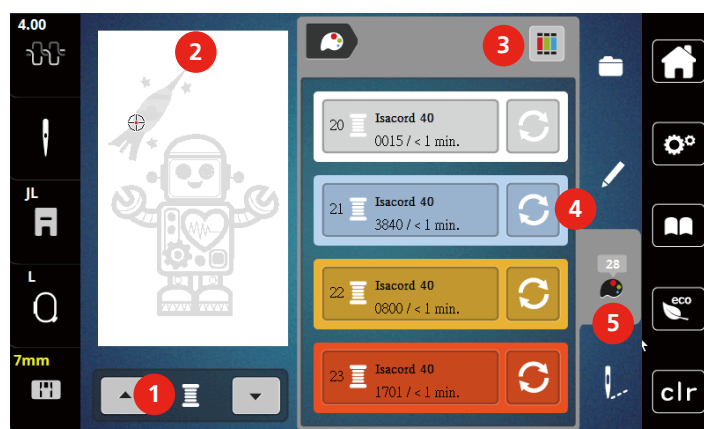

- | | | | |
|---|----------------------------------|---|-------------------|
| 1 | Colors of the Embroidery Designs | 4 | Altering Color |
| 2 | Preview for Selected Color | 5 | Color Information |
| 3 | Assign Thread Brand | | |

Changing the Colors



- > Select the embroidery design.
- > Tap «Color Information».



- > Tap «Altering Color/Brand» next to the color that needs to be changed.
- > Changing colors by searching the theme brand.
 - To display other thread brands, tap «Scroll» (6) in the upper right section of the display.
- > To select the color by inputting the color number, tap «Color Selection via Number» (7).
- > To display further colors, tap «Scroll» (8) in the lower right section of the display.
- > Select the desired color.

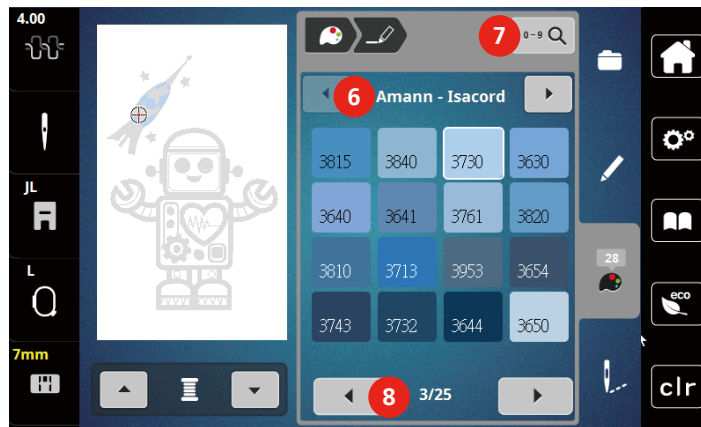

Changing the Thread Brand



- > Select the embroidery design.
- > Tap «Color Information».



- > Tap «Assign Thread Brand».



- > To display further thread brands, tap scroll (1).



- > Select a thread brand and tap «Confirm».
- Any thread colors of the selected embroidery design will be matched with the selected thread brand.

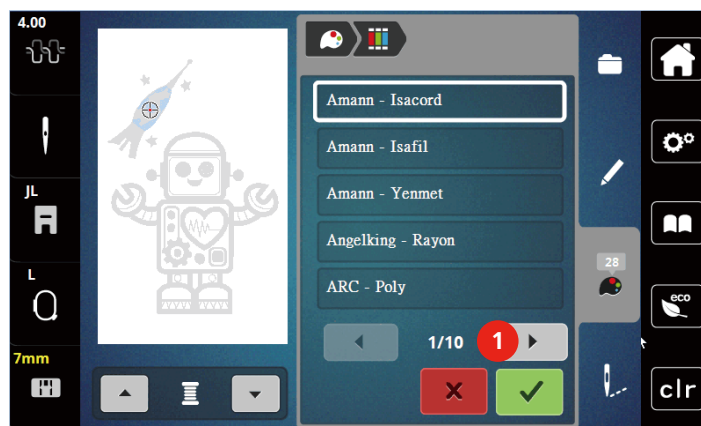

5.9 Embroidering the Embroidery Design

Overview Embroidery Menu



- | | | | |
|---|-----------------------------|---|--|
| 1 | Basting | 4 | Cut Connecting Stitches |
| 2 | Moving the Hoop | 5 | Multi-colored Embroidery Design On/Off |
| 3 | Embroidery Sequence Control | 6 | Color Indication |

Adding Basting Stitches

The basting stitches can be embroidered along the embroidery design. As a result, the fabric and the stabilizer are better fixed together.

- > Select the embroidery design.
- > Tap «Embroidery».



- > To embroider the basting stitches along an embroidery design, tap «Basting».
- > To deactivate the basting stitches, tap «Basting» again.

Moving the Hoop

If the embroidery project is so big that repeated rehooping is necessary, the embroidered design can be moved again.

- > Select the embroidery design.
- > Tap «Embroidery».



- > Tap «Move the Hoop».
- > Turn the «Upper Multi-function Knob» to move the hoop horizontally.
- > Turn the «Lower Multi-function Knob» to move the hoop vertically.

Embroidery Sequence Control when the Thread Breaks

If the thread breaks, the needle can be repositioned in the embroidery design using the function Embroidery Sequence Control.

- > Select the embroidery design.
- > Tap «Embroidery».



- > Tap «Embroidery Sequence Control».
 - A compact view of the embroidery design appears on the left side of the display. On the right side the embroidery design is shown in enlarged view.



– Repositioning via Compact View

- > Select the desired position in the overall view (1) (2).

– Repositioning via Stitch Bar

- > Select the bar in the display (3) (4).

– Repositioning via Multi-function Knobs

- > To move the embroidery hoop stitch by stitch, turn the «Upper Multi-function Knob».
- > To move the embroidery hoop in large steps, turn the «Lower Multi-function Knob».

– Repositioning via Magnifier

- > To select the desired stitch via the input, tap «Magnifier» (6).

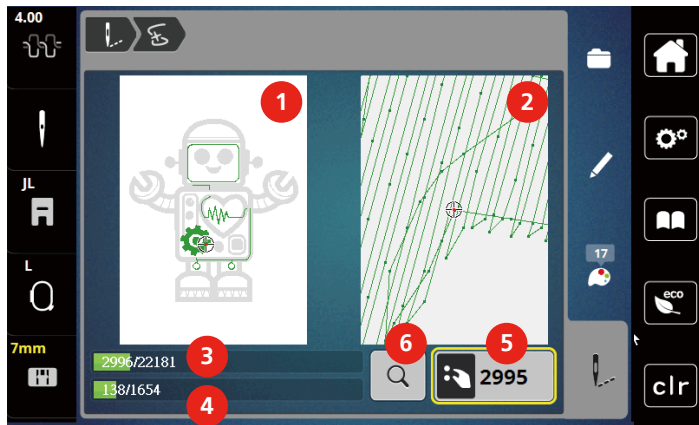

- The number in the yellow-framed icon (5) indicates the number of stitches of the embroidery process.

- > Set the needle position back so that the new start is made a few stitches before the thread has broken.

Cutting Connecting Stitches

The function is activated as standard and the connection stitches are automatically cut. If the function is deactivated, the connection stitches must be cut by hand.

- > Select the embroidery design.
- > Tap «Embroidery».



- > To switch off the function, tap «Cut Connecting Stitches».
- > To switch on the function, tap «Cut Connecting Stitches» again.



Multi-colored Embroidery Design On/Off

Multi-colored embroidery designs can also be embroidered in one color.

- > Select the embroidery design.
- > Tap «Embroidery».

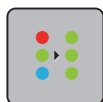

- > Tap «Multi-colored Embroidery Design On/Off».
 - The embroidery design is embroidered in one color.

Color Indication

Every color of the embroidery design can be selected individually. The hoop moves to the first stitch of the current color. The currently active color can be embroidered individually or in another sequence.

- > Select the embroidery design.
- > Tap «Embroidery».
- > Touch the icon Scroll up to select the previous color of the embroidery design.



5.10 Administering Embroidery Designs

Administering Embroidery Designs

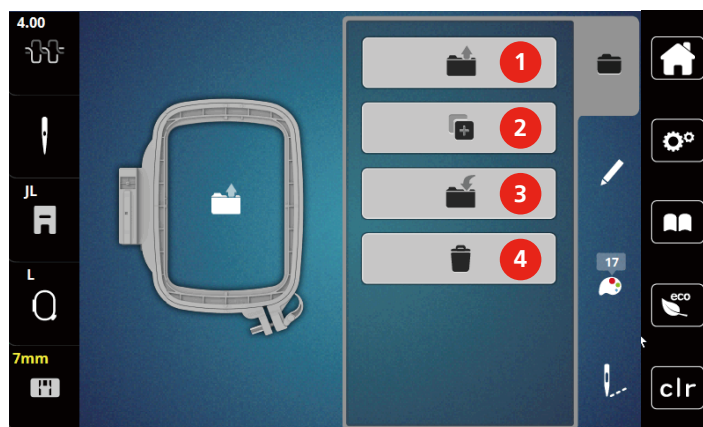

- | | | | |
|---|---------------------------------|---|-------------------------------|
| 1 | «Loading the Embroidery Design» | 3 | «Save Embroidery Design» |
| 2 | «Adding an Embroidery Design» | 4 | «Delete an Embroidery Design» |

Saving Embroidery Designs in the Personal Memory

In the file «Save Embroidery Designs» any embroidery designs including individually edited embroidery designs can be saved.

- > Select the embroidery design.
- > Edit the embroidery design.
- > Tap «Selection».





- > Tap «Save Embroidery Design».
- The embroidery design to be saved is outlined in yellow.



- The «Embroidery Machine» is activated.



- > Tap «Confirm».

Saving the Embroidery Design on the USB Stick

- > Select the embroidery design.
- > Edit the embroidery design.
- > Tap «Selection».



- > Tap «Save Embroidery Design».
- The embroidery design to be saved is outlined in yellow.

- > Insert the USB stick into the USB port of the machine.



- > Tap «USB Stick».



- > Tap «Confirm».

Overwriting the Embroidery Design in the Personal Memory

- > Select the embroidery design.
- > Edit the embroidery design.
- > Tap «Selection».



- > Tap «Save Embroidery Design».
- The embroidery design to be saved is outlined in yellow.



- The «Embroidery Machine» is activated.

- > Select the embroidery design which is to be overwritten.



- > Tap «Confirm».

Overwriting the Embroidery on the USB Stick

- > Select the embroidery design.
- > Edit the embroidery design.
- > Tap «Selection».



- > Tap «Save Embroidery Design».
- The embroidery design to be saved is outlined in yellow.

- > Insert the USB stick into the USB port of the machine.



- > Tap «USB Stick».

- > Select the embroidery design which is to be overwritten.



- > Tap «Confirm».

Loading an Embroidery Design from the Personal Memory



- > Tap «Selection».



- > Tap «Loading the Embroidery Design».



- > Select «Personal Embroidery Design».
- > Select the embroidery design.

Loading an Embroidery Design from the USB Stick



- > Tap «Selection».
- > Insert the USB stick into the USB port of the machine.



- > Tap «USB Stick».
- > Select a personal embroidery design.

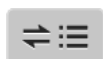

- > You can switch between the embroidery design name and embroidery design image by tapping «Display Embroidery Design Name/Embroidery Design Image» in the attachment. This is only possible when loading a design from the USB stick.

Deleting an Embroidery Design from the Personal Memory

The embroidery designs which are saved in the personal memory can be deleted individually.



- > Tap «Selection».



- > Tap «Deleting».



- The «Embroidery Machine» is activated.

- > Select the embroidery design which is to be deleted.



- > Tap «Confirm».

Deleting an Embroidery Design from the USB Stick



- > Tap «Selection».



- > Tap «Deleting».
- > Insert the USB stick into the USB port of the machine.



- > Tap «USB Stick».
- > Select the embroidery design which is to be deleted.



- > Tap «Confirm».

6 Embroidery

6.1 Embroidering via the Button «Start/Stop»

In case of a power cut the embroidery process is interrupted. After the restart the machine goes to the position which was embroidered last.



- > Push the button «Start/Stop» until the embroidery machine starts.
 - All parts of the design being in the current color are embroidered.
 - The embroidery machine stops automatically at the end.
 - Both threads are cut automatically.
 - The embroidery machine switches to the next color automatically.



- > Change the upper thread.
- > To embroider the new color, push the button «Start/Stop».
 - After having completed the embroidery design, the machine stops automatically and the threads are cut automatically.
- > To end the embroidery design, tap «Confirm» (1).

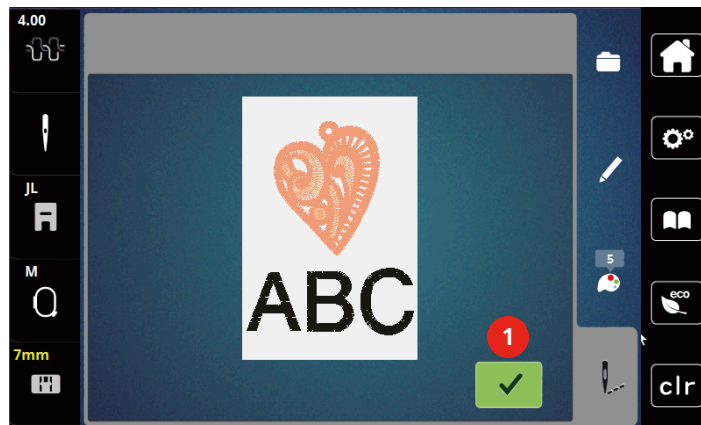

6.2 Increasing the Embroidery Speed

To ensure the best embroidery quality, the speed when embroidering is reduced depending on the embroidery position. Choose between the two options to either embroider at optimal or maximum speed. Standard = optimal speed. It has to be considered that the quality of the embroidered embroidery design at maximum speed cannot be ensured.

By switching the machine off and on, the optimal embroidery speed is activated.

Prerequisite:

- The embroidery design is selected.
- > Tap «Embroidery Speed».
 - The maximum speed is activated.
- > Tap «Embroidery Speed» again.
 - The optimal speed is activated.



6.3 Adjusting the Upper Thread Tension

The default setting of the upper thread tension is set automatically as soon as a embroidery design is selected.

When using different types of embroidery threads, the upper thread tension may vary. It may therefore be necessary to adjust the upper thread tension individually according to the embroidery project as well as the desired stitch.

The higher the upper thread tension is set, the tighter the upper thread is tensioned, and the bobbin thread is pulled deeper into the fabric. When the upper thread tension is low, the upper thread is less tightened, and the bobbin thread is pulled up less into the fabric.

Alteration of the upper thread tension affect the currently embroidery design. Permanent alterations of the upper thread tension can be made in the Setup Program.



- > Tap «Upper Thread Tension».
- > To increase or decrease the upper thread tension, move the slider.

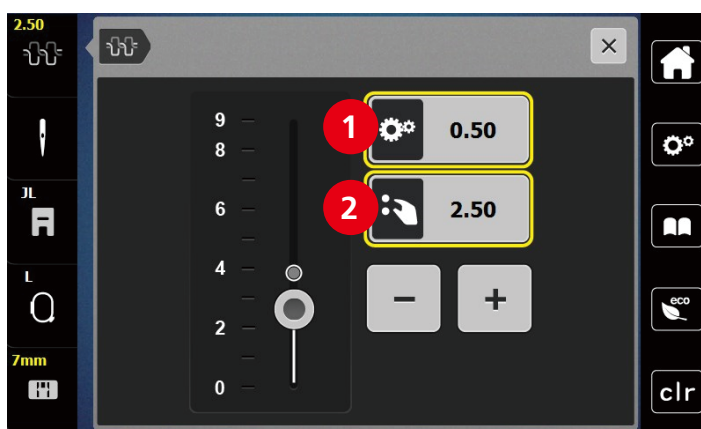

1 Permanent Alteration of Thread Tension

2 Thread Tension of the Current Embroidery Design

7 BERNINA CutWork Tool

7.1 Attaching Cutwork Tool

The CutWork Tool is available optionally. It is not included in the standard delivery of this machine.



The CutWork Tool is a very sharp accessory. Special care is required when working with this tool and keep fingers away from the sharp knife. You can find more information in the CutWork book, which is packaged with the CutWork tool.

In CutWork Mode, the upper thread, bobbin thread and thread cut sensor are deactivated.

- > Remove the embroidery foot.
- > Remove the needle.
- > Insert the CutWork Tool with the flat side to the back as far up as it will go (1). Tighten the fixing screw (2).

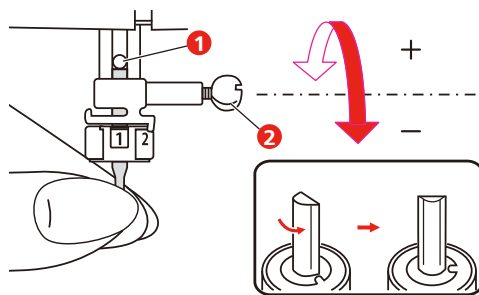

- > Attach the embroidery foot.
- > Select the attached embroidery foot in the embroidery foot selection.
- > Rotate the CutWork Tool according to the information on the color display (3).

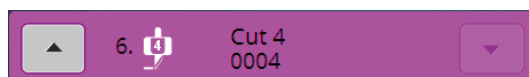
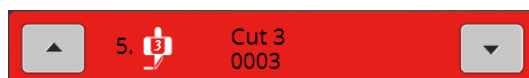
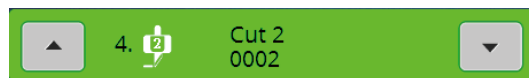
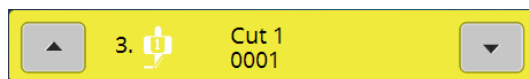

7.2 Start to Cut



- > Push the button «Start/Stop» and start to cut.
 - When it is completed, the machine stops automatically and return to Embroidery menu display.
- > Turn the CutWork Tool knife according to the cutting position on the display of Color indication (3).
- > Repeat the same actions.
- > When the cutting is completed, the machine stops automatically and shows the embroidery finished screen on the display.

8 Maintenance and Cleaning

8.1 Cleaning and Maintenance Intervals

To ensure the functionality and sewing quality of the machine, the machine must be cleaned and maintained regularly. The intervals for cleaning and maintenance of the machine depend on various factors, such as the fabrics and threads used.

As an advice to clean the machine, a message appears after 500,000 stitches.

As an advice to have the machine maintained, a message appears when 4,000,000 stitches have been sewn after a service.

8.2 Cleaning the Display

- > Clean the display when it is switched off with a soft slightly damp microfiber cloth.

8.3 Cleaning the Feed Dog

Remaining threads under the stitch plate must occasionally be removed.

- > Raise the needle and presser foot.



CAUTION

Electronically Driven Components

Risk of injury near the needle and the hook.

- > Switch the machine off and disconnect it from the power supply system.

- > Remove the needle and presser foot.
- > Lower feed dog.

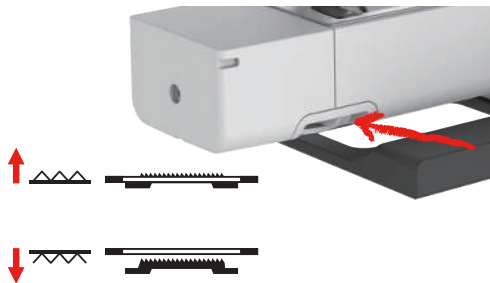

- > Remove the stitch plate.

NOTICE

Dust and Thread Residues Inside the Machine

Damage to mechanical and electronic components.

- > Use a brush or a soft cloth.
- > Do not use compressed air spray.

- > Clean the feed dog with the brush.

8.4 Cleaning the Hook



Electronically Driven Components

Risk of injury near the needle and the hook.

- > Raise the presser foot.
- > Switch the machine off and disconnect it from the power supply system.

- > Remove the presser foot and the needle.
- > Remove the stitch plate.
- > Clean the bobbin case with the brush.

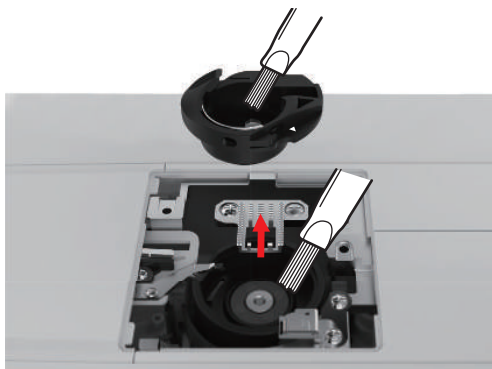

- > Set needle to topmost position.
- > Remove the bobbin case.



- > Clean the shuttle race with the brush.
- > Insert the bobbin case.
 - Note:** The markings of the bobbin case and the stitch plate must be aligned identically.
- > Fit the stitch plate.
- > Fit the bobbin cover.
- > Fit the needle and presser foot.

8.5 Oiling the Needle Bar

The needle bar may not move smoothly without lubrication. If the machine is used frequently, the needle bar should be oiled every 6 months to prevent blocking.



Electronically Driven Components

Risk of injury near the needle bar.

> Switch the machine off and disconnect it from the power supply system.

> Remove the protective cap (1) and screw (2).

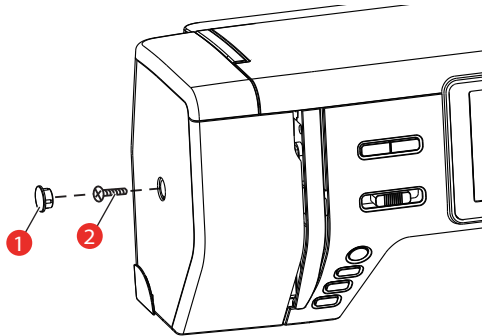

> Remove the headframe cover (3).

– After removing the headframe cover, pay attention to the moving parts.

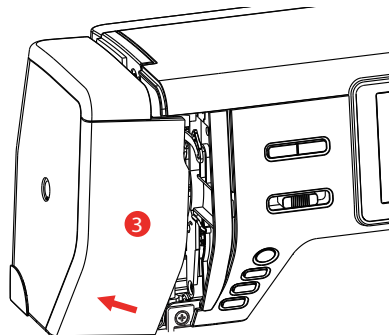

> Apply a drop of oil to the movement mechanism of the needle bar, including the connecting rod/needle bar, needle bar holder and needle bar holder (apply oil to the points marked with an arrow).

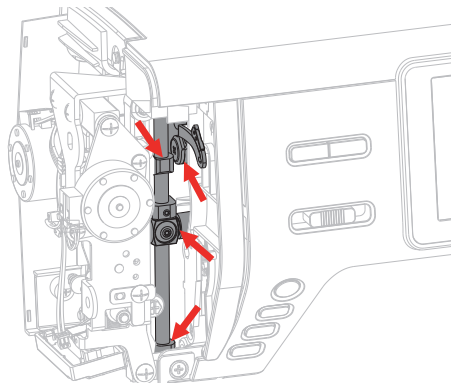

> Remove the presser foot.

> Turn the handwheel a few times and remove any excess oil with a cloth.

> Attach the headframe cover again.

9 Errors and Faults



9.1 Troubleshooting





Fault	Cause	Repair
Uneven Stitch Formation	Upper thread too tight or too loose.	> Adjust the upper thread tension.
	Needle blunt or bent.	> Replace the needle, make sure that a new BERNINA quality needle is used.
	Poor quality needle.	> Use a new BERNINA quality needle.
	Poor quality thread.	> Use quality thread.
	Incorrect needle/thread combination.	> Match the needle with the thread size.
	Incorrectly threaded.	> Rethread.
	Dust or thread remnants under the tension spring of the bobbin case.	> Remove any dust or thread remnants from under the tension spring of the bobbin case.
Skipped Stitches	Incorrect needle.	> Use the needle system 130/705H.
	Needle blunt or bent.	> Replace the needle.
	Poor quality needle.	> Use a new BERNINA quality needle.
	The needle is incorrectly inserted.	> Insert the needle with the flat side to the back as far up as it will go into the needle holder and tighten the screw.
	Incorrect needle point.	> Match the needle point to the texture of the material.
Upper Thread Breaks	Incorrect needle/thread combination.	> Match the needle with the thread size.
	Upper thread is too tight.	> Reduce the upper thread tension.
	Incorrectly threaded.	> Rethread.
	Poor quality thread.	> Use quality thread.
	The stitch plate or the hook tip is damaged.	> Contact a specialized bernette dealer to have the damages repaired. > Replace the stitch plate.

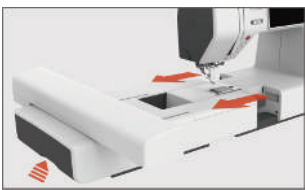
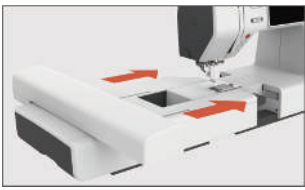
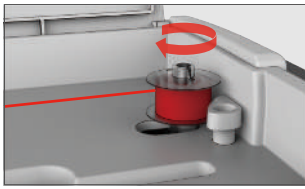
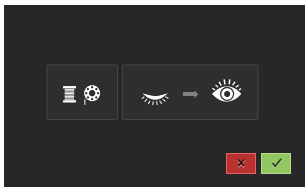
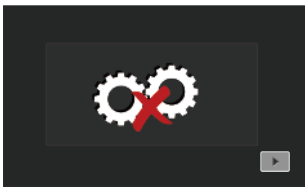

Fault	Cause	Repair
Lower Thread Breaks	The bobbin is not inserted correctly.	> Remove and reinsert the bobbin and pull on the thread. – The thread should run easily.
	Bobbin is wound incorrectly.	> Check bobbin and thread correctly.
	The stitch hole in the stitch plate is damaged.	> Contact a specialized bernette dealer to have the damages repaired. > Replace the stitch plate.
	Needle blunt or bent.	> Replace the needle.
Needle Breaks	The needle is incorrectly inserted.	> Insert the needle with the flat side to the back as far up as it will go into the needle holder and tighten the screw.
	Knotted thread.	> Use quality thread.
Display is Inactive	Incorrect calibrating data.	> Switch the machine off. > Switch the machine on and at the same time push button «Center embroidery hoop to the needle/Center embroidery design» and keep it pressed. > Recalibrate the display.
	The eco Mode is active.	> Tap «eco Mode».
Speed Too Low	Unfavorable room temperature.	> Place the machine in a warm room one hour before use.
	Settings in the Setup Program.	> Adjust the embroidery speed in the Setup Program. > Adjust the slide.
The Machine doesn't Start	Unfavorable room temperature.	> Place the machine in a warm room one hour before use. > Connect the machine and switch it on.
	The machine is damaged.	> Contact the specialized bernette dealer.
The Light of the Button «Start-/Stop» doesn't Light Up	Light is defect.	> Contact the specialized bernette dealer.
Neither the Sewing Light Nor the Light on the Freearm Lights Up	Settings in the Setup Program.	> Activate it in the Setup Program.
	The sewing light is defect.	> Contact the specialized bernette dealer.
Upper Thread Indicator Fails to Respond	Settings in the Setup Program.	> Activate it in the Setup Program.
	The upper thread indicator is defect.	> Contact the specialized bernette dealer.
Bobbin Thread Indicator doesn't React	Settings in the Setup Program.	> Activate it in the Setup Program.
	The bobbin thread indicator is defect.	> Contact the specialized bernette dealer.

Fault	Cause	Repair
Error during Software Update	The update process is blocked and the hourglass on the display is inactive.	<ul style="list-style-type: none"> > Remove the USB stick. > Switch the machine off. > Rename the firmware file from «.fw» to «.auto». > Insert the USB stick. > Switch the machine on. <ul style="list-style-type: none"> – The update starts automatically.

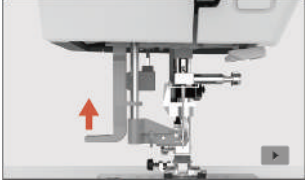
9.2 Error messages

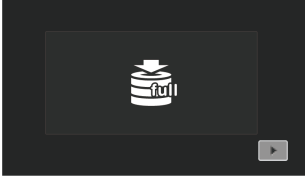
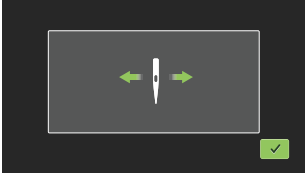
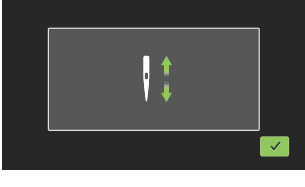
Message on the Display	Cause	Repair
	The embroidery module must be removed.	<ul style="list-style-type: none"> > Hold the embroidery module, press the release button and pull the module out.
	The embroidery module must be connected.	<ul style="list-style-type: none"> > Push the embroidery module carefully from left to right into the embroidery module connection of the machine.
	The winding unit is activated.	<ul style="list-style-type: none"> > Deactivate the winding unit.
	The thread indicator is deactivated.	<ul style="list-style-type: none"> > To switch on both thread indicators, tap «Confirm». > To keep the thread indicators switched off, tap «Cancel».
 	The main motor is not running.	<ul style="list-style-type: none"> > Turn the handwheel clockwise until the needle is at its top position. > Remove the stitch plate. > Remove the thread remnants. > Clean the hook. > Remove the hook and make sure that there are no pieces of broken needle points on the magnetic back of the hook.

Message on the Display	Cause	Repair
	The upper thread is used up.	<ul style="list-style-type: none"> > Insert a new thread spool. > Rethread.
	The upper thread has broken.	<ul style="list-style-type: none"> > Rethread.
	The bobbin thread is used up.	<ul style="list-style-type: none"> > Remove the empty bobbin, wind it again and reinsert it.
	The threader lever is not raised.	<ul style="list-style-type: none"> > Raise the threader lever.
	The USB stick is not connected.	<ul style="list-style-type: none"> > Insert the USB stick (optional accessory) into the port.
	Not enough free memory available on the USB stick (optional accessory).	<ul style="list-style-type: none"> > Delete data on the USB stick (optional accessory). > Overwrite data on the USB stick.
	The needle moves sideways.	When the stitch plate is exchanged, this illustration appears because the needle is likely to move.
	The needle moves upwards.	<ul style="list-style-type: none"> > Check whether there are any external objects near the stitch plate. > To raise the needle, tap «Confirm».

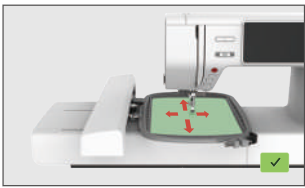
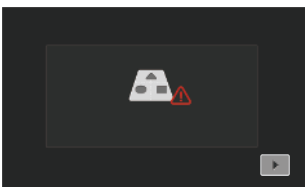
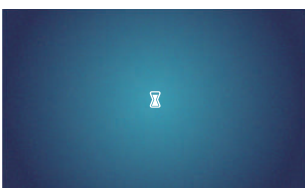
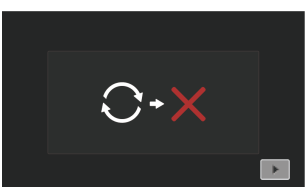
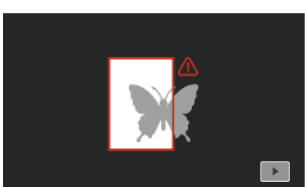
Message on the Display	Cause	Repair
	The hoop is not attached.	> Attach the hoop.
	The hoop is attached.	> Remove the embroidery hoop.
	The embroidery hoop is calibrated.	> Tap «Confirm».
	The maximum number of stitches of 120,000 is reached.	> Select another embroidery design with less stitches.
	Files are being loaded.	> Wait for processing process.
	Firmware update failed.	> Check the update file on the USB stick. > Tap «Cancel» and try the update again.
	The embroidery design is partially outside the embroidery hoop and/or is too large for the hoop.	> Reduce the size of the embroidery design. > Reposition the embroidery design. > Attach a larger hoop.

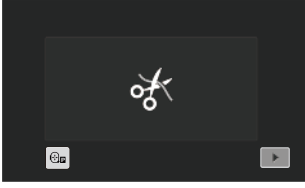
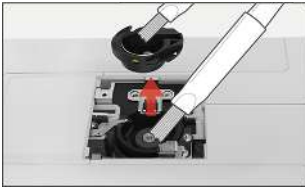
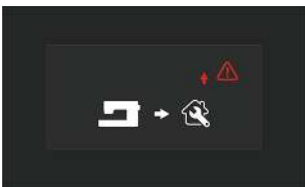
Message on the Display	Cause	Repair
	<p>This message appears when the thread cutter is adjusted after embroidery starts.</p>	<ul style="list-style-type: none"> > Cut the thread manually.
	<p>500,000 stitches have been sewn with the machine since the last cleaning advice.</p>	<ul style="list-style-type: none"> > Clean the machine. > For reference to cleaning to be made again after switching on the machine, tap «Cancel».
	<p>The machine has reached a stitch count of 4,000,000 since the last maintenance by a bernette dealer.</p>	<ul style="list-style-type: none"> > Contact your specialized bernette dealer to have the machine maintained. > For reference to maintenance to be made again after switching on the machine, tap «Cancel».

10 Technical data

Designation	Value	Unit
Sewign Light (LED)	300, 2	mA, Watt
Maximum Speed	Embroidery Mode: 850	Stitches per Minute
Measurements (w × d × h)	Without Embroidery Module: 509 x 200 x 315 With Embroidery Module: 710 x 475 x 315	mm
Weight	Machine: 8.14 Embroidery Module: 3.65	kg
Energy Consumption	90	W
Input Voltage	100 – 240	V
Protection Class (Electrical Engineering)	Protection Class II	





11 Appendix

11.1 Overview Embroidery Desings











Editing the Embroidery Design















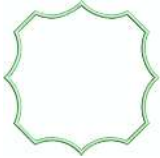

Let your creativity run free. A vast selection of embroidery designs is at your disposal.









If you see one of the following pictograms below a number of the embroidery design, you can find additional information at www.bernina.com/specialeffects.

	Detached Point		Appliqué
	Fringe Embroidery		CutWork Design (motif)

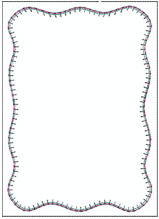

Embellishment

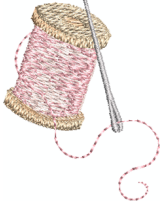
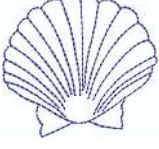
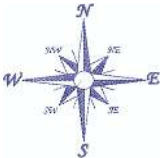
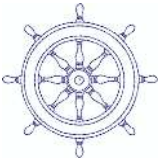









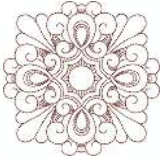

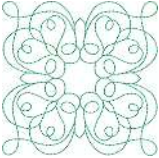
No.	Embroidery Design Colors	Width x Height in mm	No.	Embroidery Design Colors	Width x Height in mm
1 (002_bell)		50.4 103.0	2 (019_swiss)		150.4 129.4
3 (Edelweiss)		102.9 58.5	4 (12383-18)		90.6 171.2
5 (12490-03)		118 113.4	6 (12490-04)		146.4 122.4
7 (12490-05_ sized)		118 97.8	8 (12535-03_ 1_sized)		155 116
9 (12490-5_si zed)		49 100	10 (12587-57)		57.6 20.3

No.	Embroidery Design Colors	Width x Height in mm	No.	Embroidery Design Colors	Width x Height in mm
11 (12587-58)		52.8 116.2	12 (12587-59)		33 94.8
13 (12587-60)		126.2 126	14 (12606-33) 		43 70
15 (12611-27) 		136.9 137.3	16 (12611-28) 		140 140
17 (12670-03)		121 144.6	18 (12669-03)		109.4 194.6
19 (19999-002 _check_S)	KEEP CALM AND SEW SOMETHING 	125 136.4	20 (21013-29)		152 40.2
21 (21013-30)		75.8 75.8	22 (21021-04)		123 150.2
23 (21021-05)		118.8 155.6	24 (21027-01_ S)		123 122.2



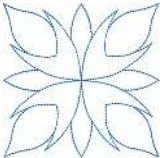

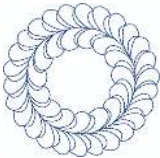







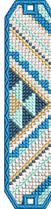

No.	Embroidery Design Colors	Width x Height in mm	No.	Embroidery Design Colors	Width x Height in mm
25 (21027-14)		120.8 120.8	26 (32078-02) 		123.4 172.9
27 (BE790308_bernette) 		155.2 178.2	28 (FB148_48)		101 89.6
29 (FB158_48)		39.6 53.2	30 (NA597)		56.6 52.8
31 (NA614)		102 101.4	32 (NA617)		96.6 96.6
33 (NB843_48)		87.6 121.2			



Quilt Designs

No.	Embroidery Design Colors	Width x Height in mm	No.	Embroidery Design Colors	Width x Height in mm
1 (12380-04)		83 89.8	2 (12380-22)		110.6 60.8







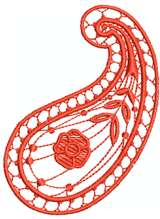



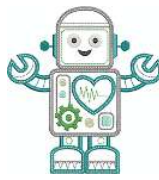

No.	Embroidery Design Colors	Width x Height in mm	No.	Embroidery Design Colors	Width x Height in mm
3 (12380-43)		123.6 123.6	4 (12383-09) 	113.0 77.2	
5 (12607-20)		122.4 122.4	6 (BD298_L_b ernette)		155 154.6
7 (BD502_48)		61.4 60.8	8 (BD513_48)		63.4 63.4
9 (BD796_48)		47.2 172.7	10 (BD800_48)		126.1 122.3
11 (BD837_48)		123.6 123.6	12 (NB934_48)		132.4 164.8
13 (Quilt 02)		101.8 101.6	14 (Quilt 09)		139.6 139.6
15 (Quilt 10)		139.6 139.6	16 (Quilt 11)		139.6 139.6









Borders and Lace

No.	Embroidery Design Colors	Width x Height in mm	No.	Embroidery Design Colors	Width x Height in mm
1 (12398-29) 		26.4 153	2 (12410-08) 		80.6 168.2
3 (12594-03) 		36.4 152	4 (12659-01) 		45.2 57.8
5 (BC015105)		118.4 123	6 (BC01506)		103 131.8
7 (BD567_48)		108 108.2	8 (BE790504)		121.4 121.4
9 (BE790702)		73 190.5	10 (BE790704)		72.5 217.7
11 (BE790705)		42.3 169.3	12 (FQ736_48)		7.9 253.2





No.	Embroidery Design Colors	Width x Height in mm	No.	Embroidery Design Colors	Width x Height in mm
13 (NY217)		67 151.6	14 (NX952)		65.6 98.6
15 (NX238)		71.1 97.9			





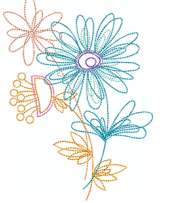









Children







No.	Embroidery Design Colors	Width x Height in mm	No.	Embroidery Design Colors	Width x Height in mm
1 (12401-17)		98.8 55.2	2 (12590-03) 		135.5 147
3 (BE790306)		132.2 151.4	4 (BE790307) 		141.5 126.9
5 (BE790313) 		99 102.4	6 (CM193_48) 		106.6 127.4
7 (CM368_48)		70.2 140	8 (CM376_48) 		100.4 97.6

No.	Embroidery Design Colors	Width x Height in mm	No.	Embroidery Design Colors	Width x Height in mm
9 (NA667)		83.8 83.8	10 (NB302-48)		68.2 80.6
11 (CK229)		88.8 98	12 (CM428_48)		78.2 106.4
13 (MS974)		94.2 98.6	14 (NZ612)		96 99.6
15 (NZ613)		103 84.1	16 (NZ611)		99.6 81.2





Flowers

















No.	Embroidery Design Colors	Width x Height in mm	No.	Embroidery Design Colors	Width x Height in mm
1 (12392-01) 		112.6 157.4	2 (12392-13)		112.6 203.4
3 (21008-24)		97.6 121.6	4 (BE790406)		120.0 180.8







No.	Embroidery Design Colors	Width x Height in mm	No.	Embroidery Design Colors	Width x Height in mm
5 (21012-04) 		123.2 124	6 (80001-23)		85 101.6
7 (BE790304_ sized)		115.2 59.6	8 (BE790401_ bernette)		155.1 220.9
9 (BE790402_ sized)		135.6 259	10 (BE790404_ bernette)		157 180.2
11 (FI135)		88.6 87.1	12 (FI136)		84.7 89.2
13 (FQ527_48)		90.4 141.4	14 (FQ562_48)		90.4 156.4
15 (FQ808_48)		123.8 142.4	16 (FQ810_48)		23.6 206.4
17 (NA146)		63.2 69.3	18 (NB039_48)		97 127

No.	Embroidery Design Colors	Width x Height in mm	No.	Embroidery Design Colors	Width x Height in mm
19 (Rose_S)		63.9 129.2	20 (Sunflower)		91 88.2
21 (FP005)		80.8 95.2	22 (FM856)		76.2 68.2
23 (FQ681_48)		107 138.8	24 (FP238_S)		61.2 65.4
25 (FQ239_48)		62.6 90.4			



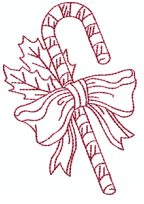
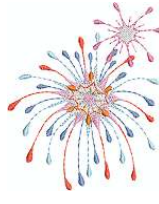

Seasons

No.	Embroidery Design Colors	Width x Height in mm	No.	Embroidery Design Colors	Width x Height in mm
1 (12384-02)		132.8 203.4	2 (12384-11)		84.4 189.8
3 (12400-03)		123.4 161.3	4 (12400-11)		74.2 211.9























No.	Embroidery Design Colors	Width x Height in mm	No.	Embroidery Design Colors	Width x Height in mm
5 (12427-01)		133.8 167.6	6 (12427-11)		81.6 126.2
7 (12443-03)		120.4 161.4	8 (12443-11)		73.4 193.1
9 (BE790301_ sized)		116.2 81.4	10 (BE790303)		69.6 70.2
11 (NA006)		72.4 91.8	12 (HG747_48) 		124 147.4
13 (12421-03)		45.8 48.4	14 (12421-11)		39.9 43.6
15 (12421-37)		67.4 61	16 (FQ749_48)		77.6 94.8
17 (HE252) 		88.1 144.9	18 (HE255) 		133.2 127.2

No.	Embroidery Design Colors	Width x Height in mm	No.	Embroidery Design Colors	Width x Height in mm
19 (HE563)		63.2 129.4	20 (HE919_48)		89.2 69.2
21 (HG053_48)		122 121.8	22 (HG795_48)		89.2 164.4
23 (HD382)		66 97.4	24 (HD246)		80.8 99
25 (HE179)		89 95.2			



Asia

No.	Embroidery Design Colors	Width x Height in mm	No.	Embroidery Design Colors	Width x Height in mm
1 (FB276_48_ sized)		115.1 103.2	2 (FB283_48)		102.4 109.4
3 (FQ194_48)		120.2 118.4	4 (NB124_48 _sized 100%)		155 118.6





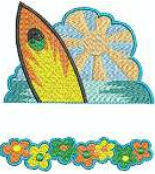









Sport/Hobby















No.	Embroidery Design Colors	Width x Height in mm	No.	Embroidery Design Colors	Width x Height in mm
1 (12465-33)		80 79.8	2 (NX688)		92.2 85.6
3 (12611-08) 		80 119.7	4 (12611-21) 		71.7 155.8
5 (12611-22) 		71.7 155.8	6 (12611-23) 		71.7 155.8
7 (12677-01_ sized) 		117.2 115.2	8 (12677-02) 		116.4 115
9 (12677-03_ sized) 		117 82.4	10 (80085-25) 		134.8 166.2
11 (BE790601_ S)		80.3 80.2	12 (BE790602)		80.2 75.6
13 (BE790603)		80.4 74.8	14 (BE790604)		79.8 80.4











No.	Embroidery Design Colors	Width x Height in mm	No.	Embroidery Design Colors	Width x Height in mm
15 (BE790604)		79.6 79.6	16 (BE790606_ S)		100.2 86
17 (BE790607)		79.8 74.4	18 (BE790608)		80.4 80
19 (SP980)		63.3 63.6	20 (SP989)		101.6 82.4
21 (CK510)		76.2 60	22 (CK522)		70.8 53.2
23 (CK970)		84.8 81.6	24 (LT749)		99.2 38.4
25 (LT920)		89.1 55.6	26 (CM442_48)		46.4 47
27 (LT870)		97.6 57	28 (NB759)		98.8 61.6
29 (RC675_S)		101.6 79.6	30 (RC765_48)		100.4 99

No.	Embroidery Design Colors	Width x Height in mm	No.	Embroidery Design Colors	Width x Height in mm
31 (SR067)		87.6 96.8	32 (SR589)		95.2 66.6







Animals

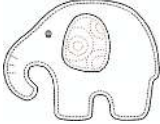

No.	Embroidery Design Colors	Width x Height in mm	No.	Embroidery Design Colors	Width x Height in mm
1 (BE790302)		68.4 66.4	2 (12672-02)		138 133.4
3 (CM022_4 8)		89.2 97	4 (CM142_4 8)		56.6 66.8
5 (CM211_4 8) 		80.6 70.6	6 (CM213_4 8) 		58.2 102
7 (CM220_4 8) 		71.4 71.8	8 (CM226_4 8) 		63.2 63
9 (CM286_4 8)		97.8 82.4	10 (CM362_4 8_sized) 		115.1 107.8

No.	Embroidery Design Colors	Width x Height in mm	No.	Embroidery Design Colors	Width x Height in mm
11 (CM384_4 8)		77.4 80.6	12 (CM465_4 8_sized)		48.2 33
13 (DEC104)		10.4 13	14 (FQ617_48)		118 198.2
15 (FQ624_48)		64.5 144.2	16 (FQ945_48 _S)		93.8 95
17 (LJ699)		93.2 98	18 (WM785)		84.6 103.4
19 (WP201_4 8)		76.2 92	20 (WP325_4 8)		77.8 94
21 (WP217_4 8)		93.8 78.2	22 (WP224_4 8)		100.4 111
23 (WP415_4 8)		132.4 148.4	24 (WP421_4 8)		95.8 137.6

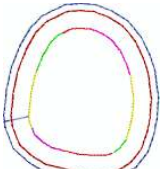

No.	Embroidery Design Colors	Width x Height in mm	No.	Embroidery Design Colors	Width x Height in mm
25 (WS610_4 8_sized)		120 104.4	26 (CM442H D26748)		65.2 51.4
27 (WM784)		106 114.4	28 (BE790305) 		118.2 145.6
29 (BE790309) 		87.5 149.8	30 (BE790311) 		114.1 152.5
31 (BE790312) 		122 133			

CutWork

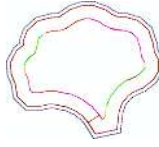
No.	Embroidery Design Colors	Width x Height in mm	No.	Embroidery Design Colors	Width x Height in mm
1 (CM594_4 8)		96 75.6	2 (CM594_4 8_CWA01) 		90.8 110.0
3 (CM594_4 8_CWA02) 		43.6 50.2	4 (FS344_48)		94.4 101

No.	Embroidery Design Colors	Width x Height in mm	No.	Embroidery Design Colors	Width x Height in mm
5 (FS345_48)		92.6 104.9	6 (FS345_48 _CWA) 		80.6 72.2

Campaign

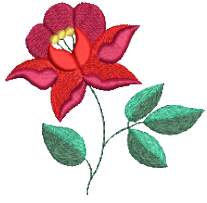
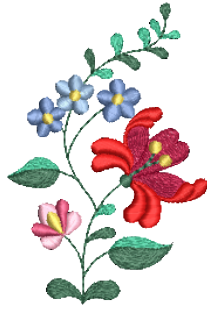
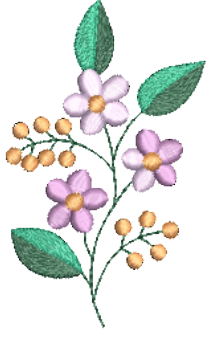
No.	Embroidery Design Colors	Width x Height in mm	No.	Embroidery Design Colors	Width x Height in mm
1 (Campaign _3_elen ts)		118.9 216.7	2 (Campaign _1_elen t)		75.3 69.3
3 (FB060)		75.7 72.9	4 (FB062)		60 91
5 (FB069)		53.1 87.4			

Index

A

Adjusting the Hoop.....	45
Altering the Stitch Density.....	62
Attaching the Hoop.....	42
Attaching the Module.....	28

C

Calibrating the Display.....	49
Calling up the Tutorial.....	52
Checking the Firmware Version.....	50
Cleaning the Feed Dog.....	74
Cleaning the Hook.....	75
Combining Embroidery Designs.....	63

D

Deactivating Securing Stitches.....	46
-------------------------------------	----

E

Embroidery Module.....	15
Embroidery Test.....	23
Environmental Protection.....	9
Error Messages.....	79
Explanation of Symbols.....	10

F

Fitting the Embroidery Needle.....	30
------------------------------------	----

I

Inserting the Spool.....	27
Inserting the Spool Cap.....	26

M

Maintenance and Cleaning.....	74
-------------------------------	----

N

Needle, Thread, Fabric.....	20
Needle/Thread Combination.....	21
Needles Overview.....	20

O

Overview of Embroidery Designs.....	84
-------------------------------------	----

P

Power Cable.....	25
USA/Canada.....	25
Preparing the Threading.....	31

R

Regulating the Speed.....	55
Restoring the Default Settings.....	49

S

Safety Instructions.....	6
Selecting an Embroidery Design.....	37
Selecting the Language.....	51
Setting the Display Brightness.....	48
Setting the Display Color.....	47
Setting the Lower Thread Indicator.....	48
Setting the Upper Thread Indicator.....	48
Sound On/Off.....	48

T

Technical Specifications.....	83
Threading the Bobbin Thread.....	36
Threading the Upper Thread.....	31
Troubleshooting.....	77

U

Updating the Machine Firmware.....	50
Using eco Mode.....	52
Using the Spool Net.....	26

W

Winding the Bobbin Thread.....	34
--------------------------------	----



www.mybernette.com/b70DECO

2023-06 EN
5020070.40A.04

© BERNINA International AG
Steckborn CH, www.bernina.com