

Longarm Frame Assembly Instructions

November 2023

Table of Contents

What's Included	1
Frame Parts List	2
Frame Hardware List	4
Frame Box Contents	5
Step 1: End Leg Assembly	6
Step 2: Table Assembly	7
Step 3: Middle Leg Assembly.....	9
Step 4: End Leg to Table Assembly	10
Step 5: Precision-Glide Track Assembly	12
Step 6: Side Arm Height Tube Assembly	15
Step 7: Connector Arm to Front Pole Side Arm Assembly	16
Step 8: Rear Pole Side Arm to Frame Assembly	17
Step 9: Ratchet-Stop Assembly.....	18
Step 10: Pole Coupler Assembly.....	20
Step 11: Pole End Assembly	21
Step 12: Pole to Frame Assembly.....	24
Step 13: Hook and Loop Strip Attachment.....	25
Step 14: Attach Leaders	26
Step 15: Adjusting Side Arm Pole Bracket Position/Mode.....	27
Step 16: Adjusting Side Arm Pole Bracket Height and Length	30
Step 17: Bungee Clamp Assembly	33
Step 18: Adjusting Frame Height	34
Using the Pole Cradles	35
Troubleshooting	36

What's Included

Your frame should have been delivered in seven separate boxes. Upon opening, please check immediately to see if you have received the items listed in the Parts and Hardware lists found on pages 2, 3, 4 and 5.

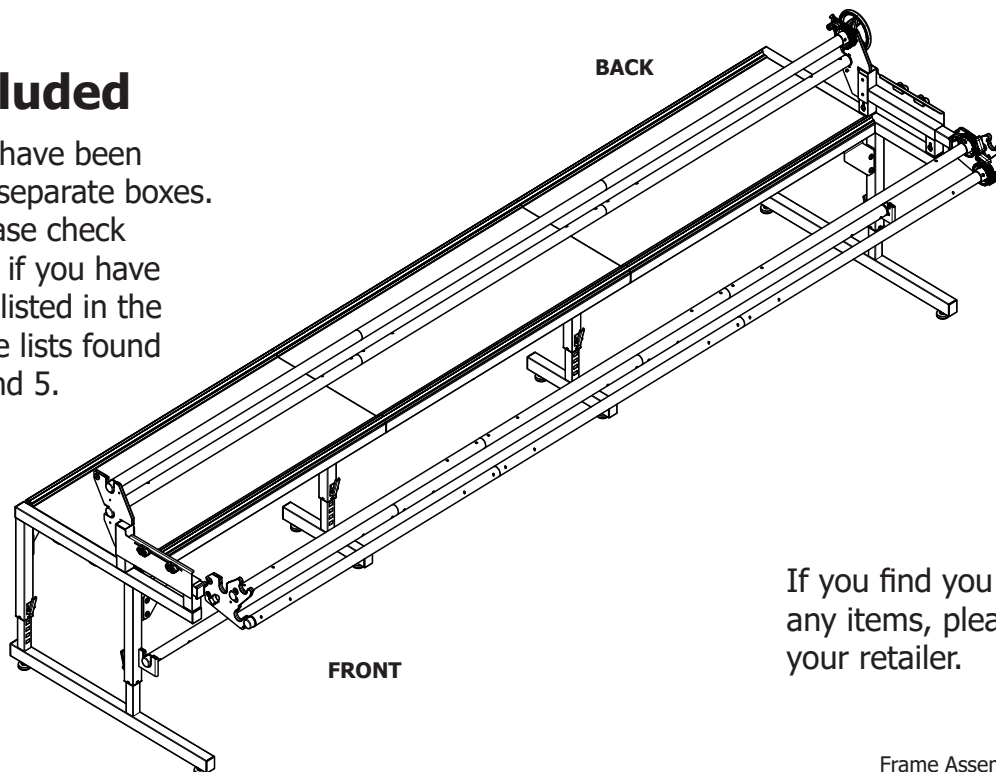

If you find you are missing any items, please contact your retailer.

Frame Parts List

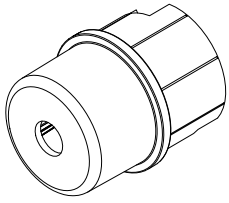

Pole End
(5)
Box 4
Part# QF09341-703

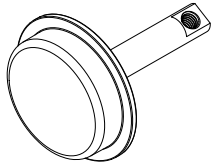

Locking Retainer
(5)
Box 4
Part# QF09341-706

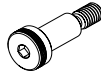

Shoulder Screw
(5)
Box 4
8mmx16 SHLD M6 THRD
QF09341-708



Shoulder Screw (2)
8mmx10 SHLD M6
THRD **Box 4**
Part# QF09341-108

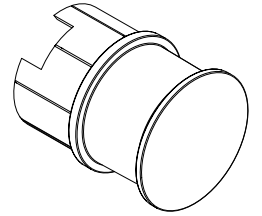

Retainer Pole End
(4)
Box 4
QF09341-707

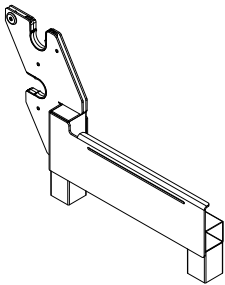

Left Rear Pole Side Arm Assy (1)
Box 5
QF09341-200-2

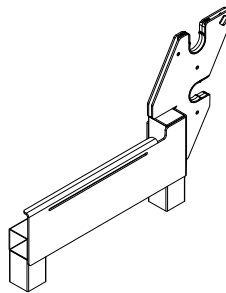

Right Rear Pole Side Arm Assy (1)
Box 5
QF09341-100-2

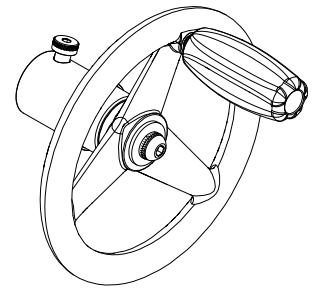

Handwheel Assembly (1)
Box 4
Part# QF09341-750

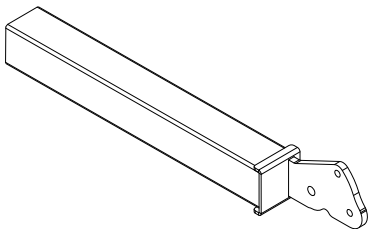

Left Connecting Arm (1)
Box 5
QF09341-202

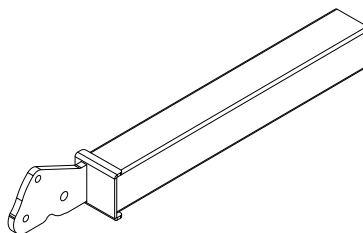

Right Connecting Arm (1)
Box 5
QF09341-102

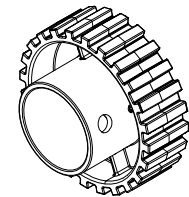

Ratchet Wheel (3)
Box 4
Part# QF09341-704

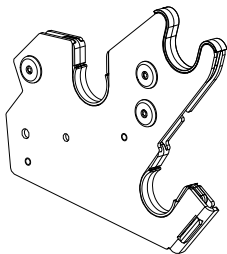

Left Front Pole Side Arm Assy (1)
Box 5
QF09341-220

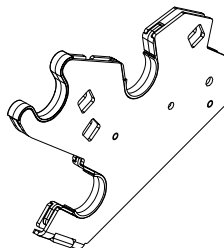

Right Front Pole Side Arm Assy (1)
Box 5
QF09341-120

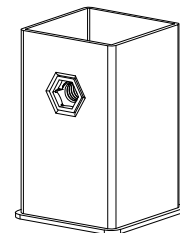

Tube, Side Arm Height (4)
Box 5
QF09341-104

Frame Parts List - Continued

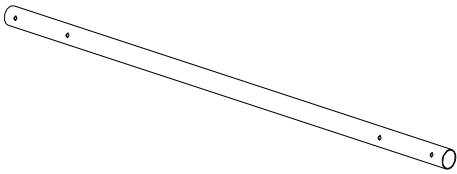

4-Foot Pole Sections (One 2-foot pole for 10-foot frame)
 4-Foot Part# QF09341-701 **Box 2**
 2-Foot Part# QF09337-701 **Box 6**

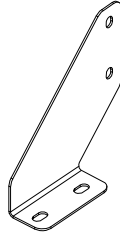

Corner Brace (2)
Box 5
 QF09341-404

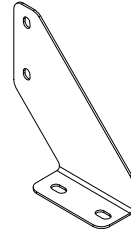

Corner Brace Mirrored (2)
Box 5
 QF09341-405

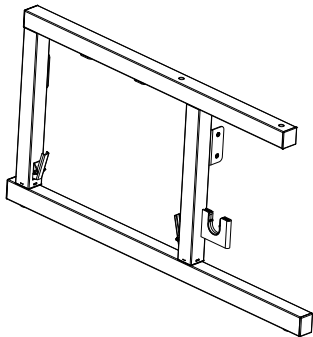

Left Leg Assembly (1)
Box 3
 Part# QF09341-500-2
 consists of
 1, QF09341-500 upper leg left
 1, QF09341-407 lower leg

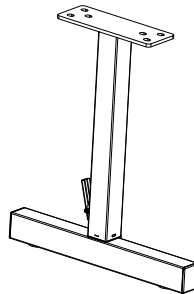

Middle Leg Assembly (2)
Box 4
 Part# QF09341-600

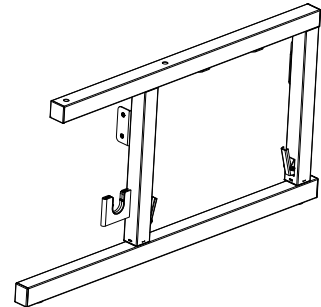

Right Leg Assembly (1)
Box 3
 Part# QF09341-400-2
 consists of
 1, QF09341-400 upper leg right
 1, QF09341-407 lower leg

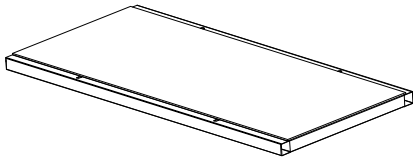

4-Foot Table Section
 (One 2-foot section for 10-foot frame)
 4-Foot Part# QF09341-300 **Box 2**
 2-Foot Part# QF09337-300 **Box 6**
Note: the above part #s include table frame and plastic table top only; however, they normally ship with two track supports and four QF09341-03 coupler screws pre-assembled when an entire frame is shipped

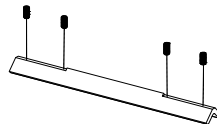
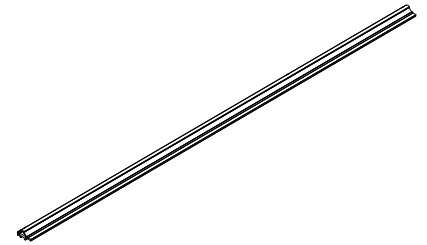
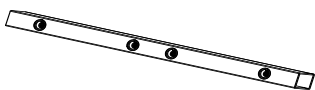

Table Frame Coupler (4) Box 5
Screws (M8 X 16 SKS) (16) Box 4
 Coupler Part# QF09341-04
 Screw Part# QF09341-05 (M8 X 16 SKS)



4-Foot Track Support Section
 4-Foot Part# QF09318-02 **Box 2**
 2-Foot Part# QF09304-02 **Box 6**
These come pre-assembled to the table section with QF09341-03 screws with spacer when an entire frame is shipped.



Pole Coupler (10)
Box 5
 Part# QF09341-702

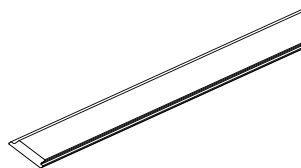

12-foot Black Plastic Track (4)
Box 3
 Part# QF09318-04
 Note: you will need to cut the 12 foot tracks down to 10 foot for the 10-foot frame.

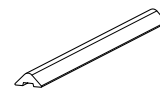

Track Support Coupler (4)
Box 4
 Part# QF09318-03

Frame Hardware List

Found in the inner carton in Box 4



Screw-M5 X 8 SKB ZN
(24)
Track Support Coupler
Screws
Part# QF09318-304



Knob (2)
Part# QM11780



Snap Button (2)
Part# QF09318-714

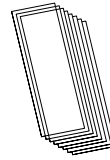

Track Alignment Kit (1)
Part# QF00100

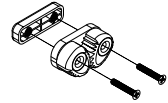

Bungee Grabber™ Assy (4)
Part #HG10003
(Screw Part #QF10050-
If screw only needed later)

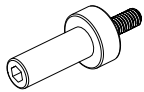

M6 Screw w/
Spacer (16)
Part# QF09341-03



Screw-M8 X 16
SBHCS
w/Flange (36)
Part# QF09318-07



Pole Coupler
Screw (40)
M10 X 20M SKS
Part# QM11735

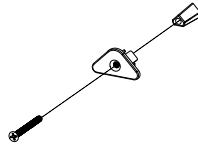

Retainer-Locking
Track Ext (4)
Part# QF09341-113
includes screw, cap
and wedge as shown

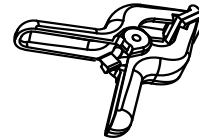

Bungee Clamp (4)
Part# QF09318-110



16mm Wrench
Part# QM40230

**12-pre-installed
to table
assemblies, 4
more used on
side arm height
tubes**

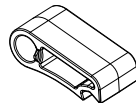

Ratchet-Stop (4)
Part# QF09318-203



Ratchet-Stop Mount (4)
Part# QF09318-202

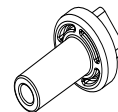

Ratchet-Stop
Bushing (4)
Part# QF09318-201



Ratchet-Stop
Holder (4)
Part# QF09318-205

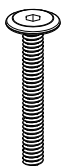

Connector Screw (4)
M6 x 48mm
Part# QF09318-204



5mm Hex Tool (1)
Part# QM40415



5mm L Hex Tool (1)
PART# QM10289

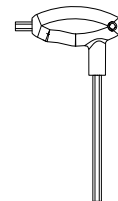

4mm Hex Tool (1)
Part# QF09318-112

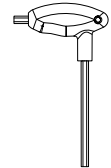

3mm Hex Tool (1)
Part# QF09318-111

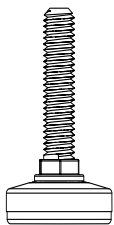

Leveling Foot (8)
Part# QF09318-108

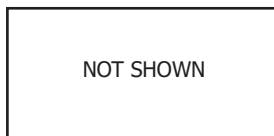

Velcro Set 12-Foot
(1)
Part# QF00669

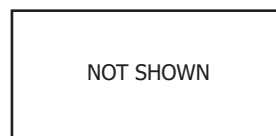

Leader Super Set 9.5'
(1)
for 10-foot frame
Part# QF09548

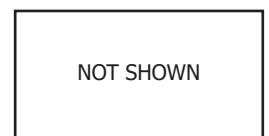

Leader Super Set 11.5'
(1)
for 12-foot frame
Part# QF09558

Frame Box Contents

12-foot Frame

Box 1 (qty 1)
11 1/2-foot leader set (qty 1)

Box 2 (qty 3)
Table Assembly – 4 feet (qty 1)
Pole Sections – 4 feet (qty 5)

Box 3 (qty 1)
Leg Assembly, Right (qty 1)
Leg Assembly, Left (qty 1)
Track Insert (qty 4)

Box 4 (qty 1)
Middle Leg (qty 2)
Inner Carton (qty 1): includes plastic parts,
screws, and tools

Box 5 (qty 1)
Table Frame Coupler (qty 4)
Pole Coupler (qty 10)
Connector Arm - Left (qty 1)
Connector Arm - Right (qty 1)
Side Arm - Left (qty 1)
Side Arm - Right (qty 1)
Side Arm - Left Front (qty 1)
Side Arm - Right Front (qty 1)
Brace, Corner (qty 2)
Brace, Corner Mirrored (qty 2)
Tube, Side Arm Height (qty 4)

10-foot Frame

Box 1 (qty 1)
9 1/2-foot leader set (qty 1)

Box 2 (qty 2)
Table Assembly – 4 feet (qty 1)
Pole Sections – 4 feet (qty 5)

Box 3 (qty 1)
Leg Assembly, Right (qty 1)
Leg Assembly, Left (qty 1)
Track Insert (qty 4)

Box 4 (qty 1)
Middle Leg (qty 2)
Inner Carton (qty 1): includes plastic parts,
screws, and tools

Box 5 (qty 1)
Table Frame Coupler (qty 4)
Pole Coupler (qty 10)
Connector Arm - Left (qty 1)
Connector Arm - Right (qty 1)
Side Arm - Left (qty 1)
Side Arm - Right (qty 1)
Side Arm - Left Front (qty 1)
Side Arm - Right Front (qty 1)
Brace, Corner (qty 2)
Brace, Corner Mirrored (qty 2)
Tube, Side Arm Height (qty 4)

Box 6 (qty 1)
Table Assembly – 2 feet (qty 1)
Pole Sections – 2 feet (qty 5)

Step 1: End Leg Assembly

 **NOTE:** Assembly will be easier if all connections are tightened lightly at first (called finger-tightening), as instructed, while assembling the frame. Tighten with tools wrench only when instructed.

Why is this important? If you tighten as you go, you may have trouble getting all the parts to align properly.

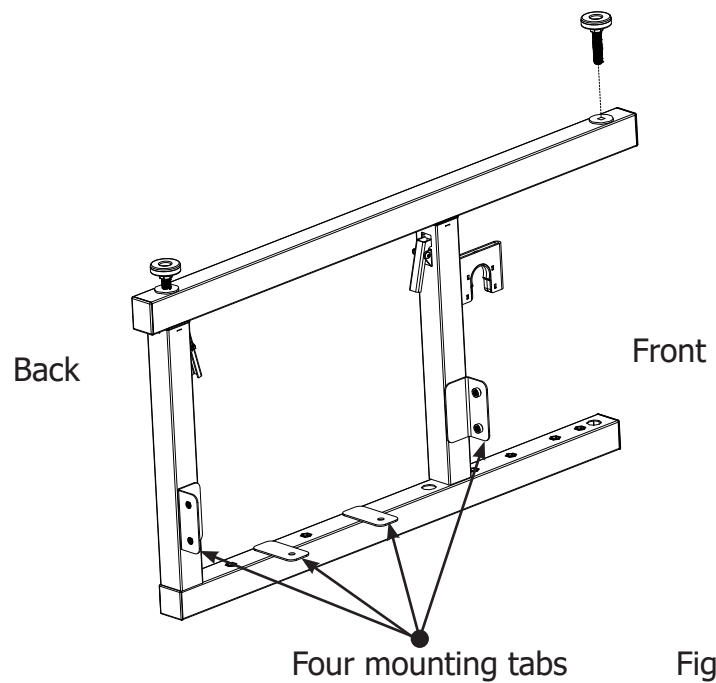

 **NOTE:** Make sure the mounting tabs are on the inside so they can attach to the table section assembly before proceeding.

(Fig. 1-1)

Parts Needed

1 - right side leg assembly
1 - left side leg assembly
4 - leveling feet

Tools Required

16mm Wrench

1-1: Screw two (2) leveling feet about half way into the bottom of the left side leg, as shown in Fig. 1-1. This makes it easier to adjust them up or down for levelling later on.

1-2: Repeat Step 1-1 for the right side leg.

Step 2: Table Assembly

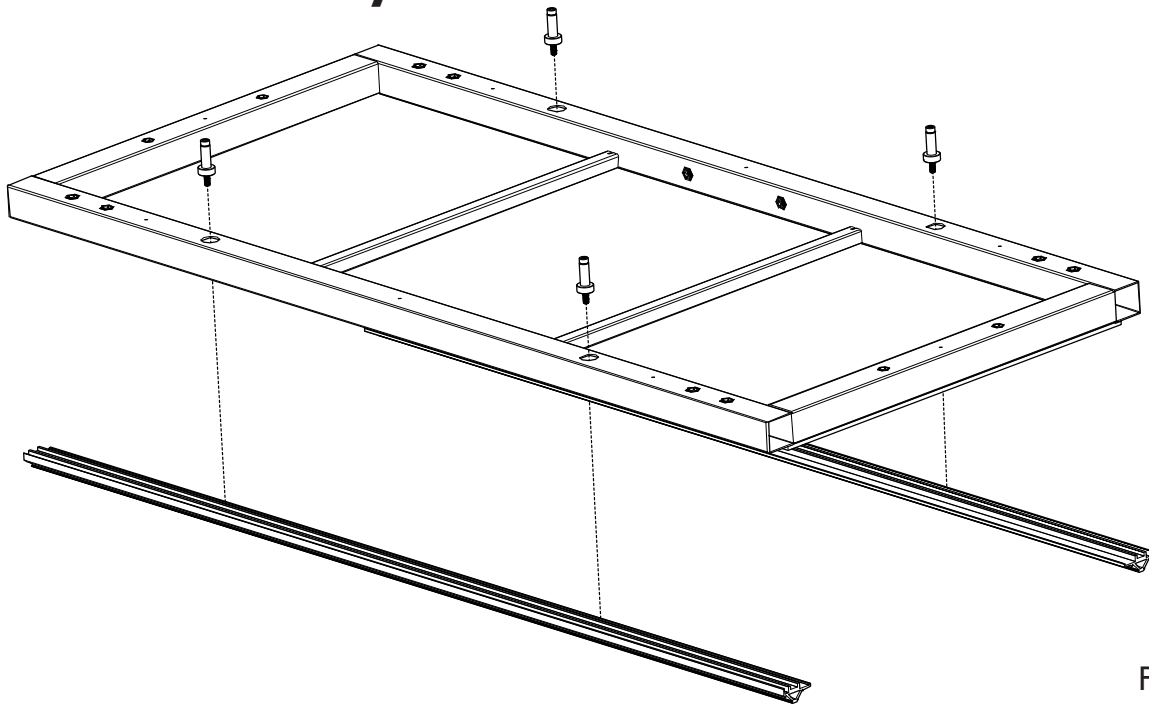



Fig. 2-1

Parts Needed

- 3 - table section
- 12-foot: three 4-foot sections
- 10-foot: two 4-foot sections
one 2-foot section

Tools Required

5mm Hex Tool (provided)

 **NOTE:** For this step, a carpeted surface is recommended for the protection of your floor and frame.

If you are working on a hard surface (such as tile, hardwood, or concrete), cover the surface with a blanket or rug.

 **NOTE:** Skip **Steps 2 and 3** if you are setting the frame up at four feet. The 12-foot frame uses a 4-foot center/middle table section. **The 10-foot frame uses a 2-foot center/middle table section.**

2-1: Prepare the three table sections by removing the two screws with spacer assemblies from each track support. Set the track supports and screws with spacer assemblies aside. These will be reinstalled in Step 5 (see Fig. 5-5). These were assembled on the table temporarily to protect them during shipping.

Step 2: Table Assembly (continued)

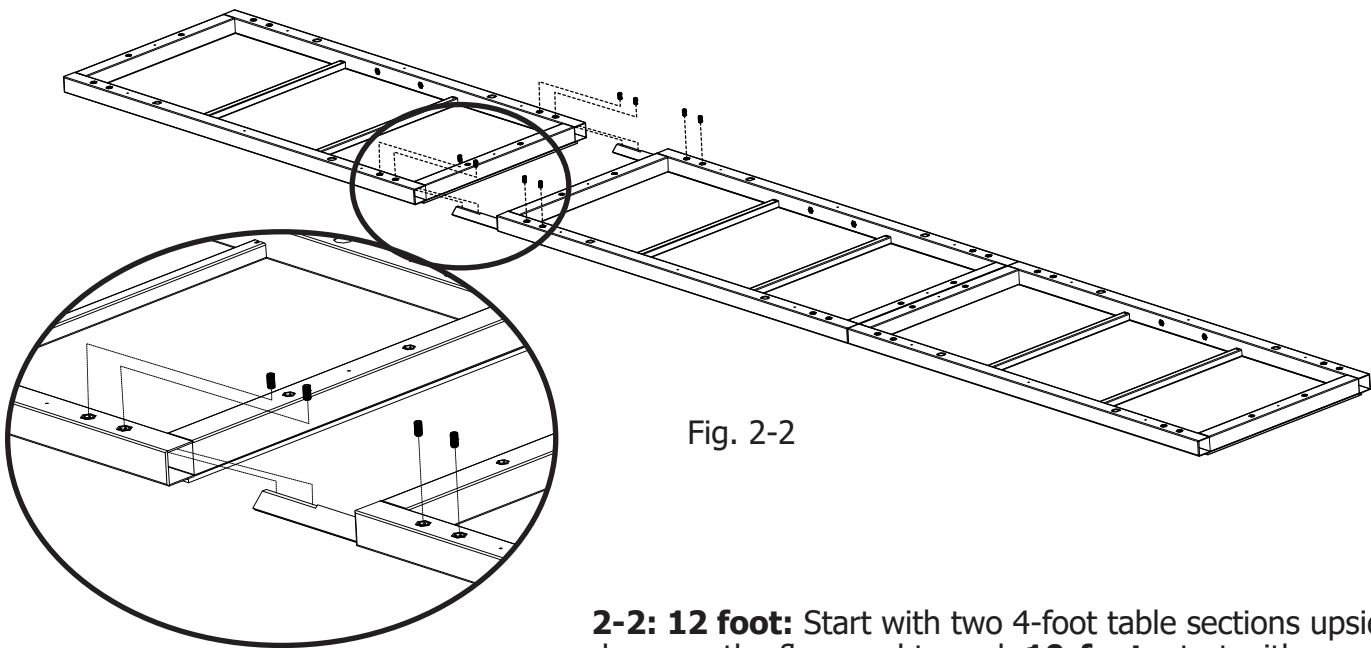

Fig. 2-2

Parts Needed

- 3 - table section
 - 12-foot: three 4-foot sections
 - 10-foot: two 4-foot sections
one 2-foot section
- 4 - table frame coupler
- 16 - Screw-M8 x 16mm SKS

Tools Required

- 4mm Hex Tool (provided)



NOTE: For this step, a carpeted surface is recommended to protect your floor and frame.

If you are working on a hard surface (such as tile, hardwood, or concrete), cover the surface with a blanket or rug.



NOTE: Skip **Steps 2 and 3** if you are setting the frame up at four feet. The 12-foot frame uses a 4-foot center/middle table section. **The 10-foot frame uses a 2-foot center/middle table section.**



NOTE: Remember to lightly tighten all screws first. Once all are in place, you may fully tighten them as instructed.

2-2: 12 foot: Start with two 4-foot table sections upside-down on the floor end to end. **10-foot:** start with one 2-foot and one 4-foot table section upside-down on the floor, end to end (as shown in Fig. 2-2). Join the sections together by placing a table frame coupler half way into each side of the middle section, lining up the flats on the coupler with the holes in the section. Place an M8 X 16 screw into the two holes and lightly tighten the screws onto the coupler flats. Repeat this process for the two holes on the other side of the section.

2-3: Slide the outside section onto the two couplers until the two table sections make good contact with each other on both sides without any gap.

2-4: Check that the holes in the section align with the flats on the coupler on both sides of the section.

2-5: Place an M8 X 16 screw into the two holes and lightly tighten the screws onto the coupler flats. Repeat this process for the two holes on the other side of the section.

2-6: Check that the table sections are as close together as possible to remove any gap.

2-7: Using the 4mm Hex Tool, fully tighten the four screws on each table frame coupler.

2-8: Repeat **Steps 2-2** through **2-7** to add the remaining 4-foot section.

Important: For the 10-foot frame, the 2-foot section goes in the center.

2-9: All 16 coupler screws should now be fully tightened.

Step 3: Middle Leg Assembly

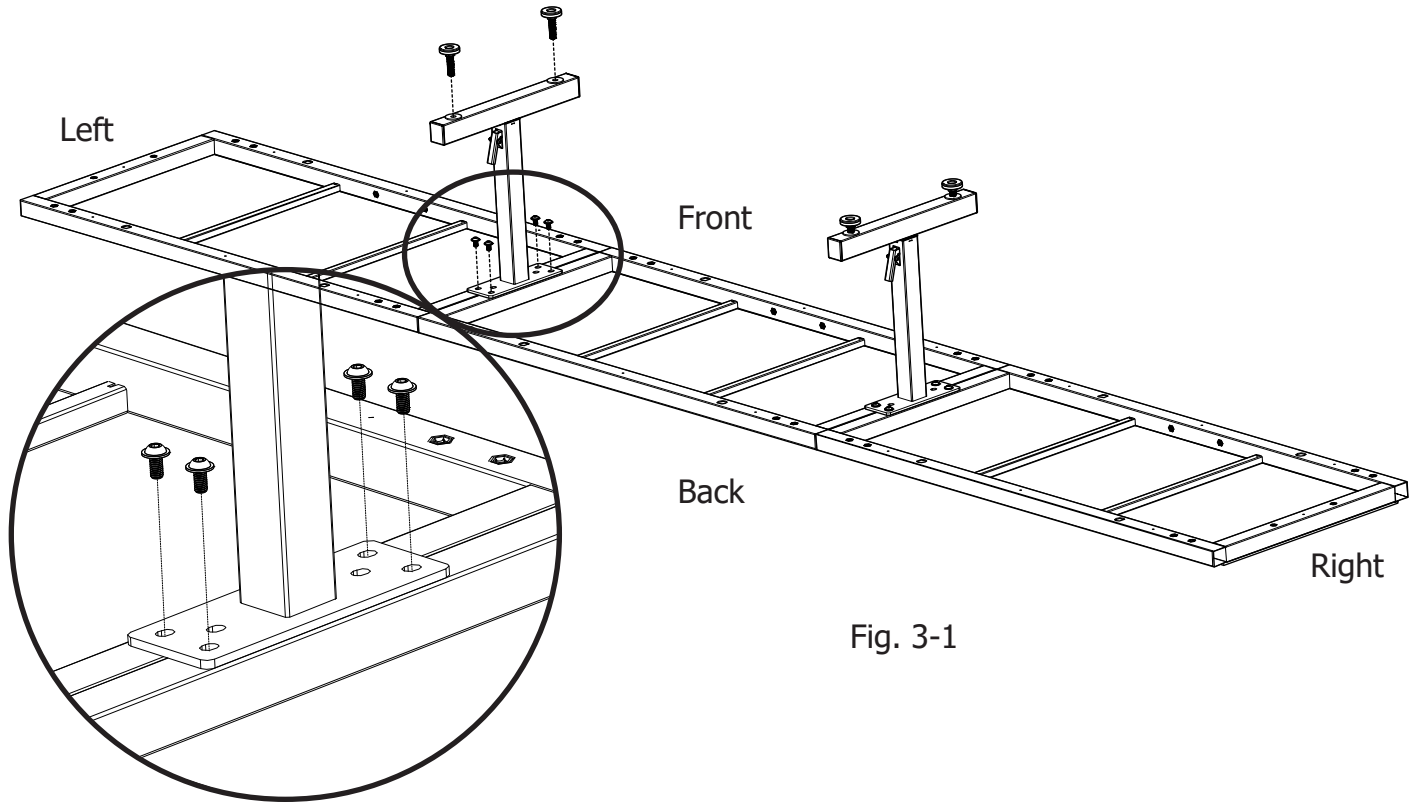

Fig. 3-1



NOTE:

If instructions were carefully followed in Section 2, the gap between the table sections where the sections meet should be minimal. The middle legs' mounting plate holes should align properly. Check to ensure that all table frame coupler screws are tightened before tightening the four middle leg screws.

Parts Needed

- 1 - table assembly
- 2 - middle legs
- 4 - leveling feet
- 8 - M8 x 16mm SBHCS

Tools Required

- 5mm Hex Tool (provided)

3-1: Install two (2) leveling feet all the way in and then 1/2 turn out.



NOTE: This will ensure the two middle legs will not be too high to start with. The leveling feet can be easily turned down to the floor as needed when leveling the frame later on.

3-2: Place the middle leg assembly over two joined table sections, aligning the mounting plate with the threaded inserts in the table sections. Attach the middle leg assembly using four (4) M8 x 16mm SBHCS.



NOTE: The direction the height adjustment levers face on the middle legs determines the back of the frame in this step.

3-3: Fully tighten the four (4) screws.

3-4: Repeat **Steps 3-1** through **3-3** to attach the remaining middle leg. Be sure the middle leg assemblies are set at the lowest settings and that the height adjustment levers are facing in the same direction, toward the back of the table as shown in Fig. 3-1.

Step 4: End Leg to Table Assembly

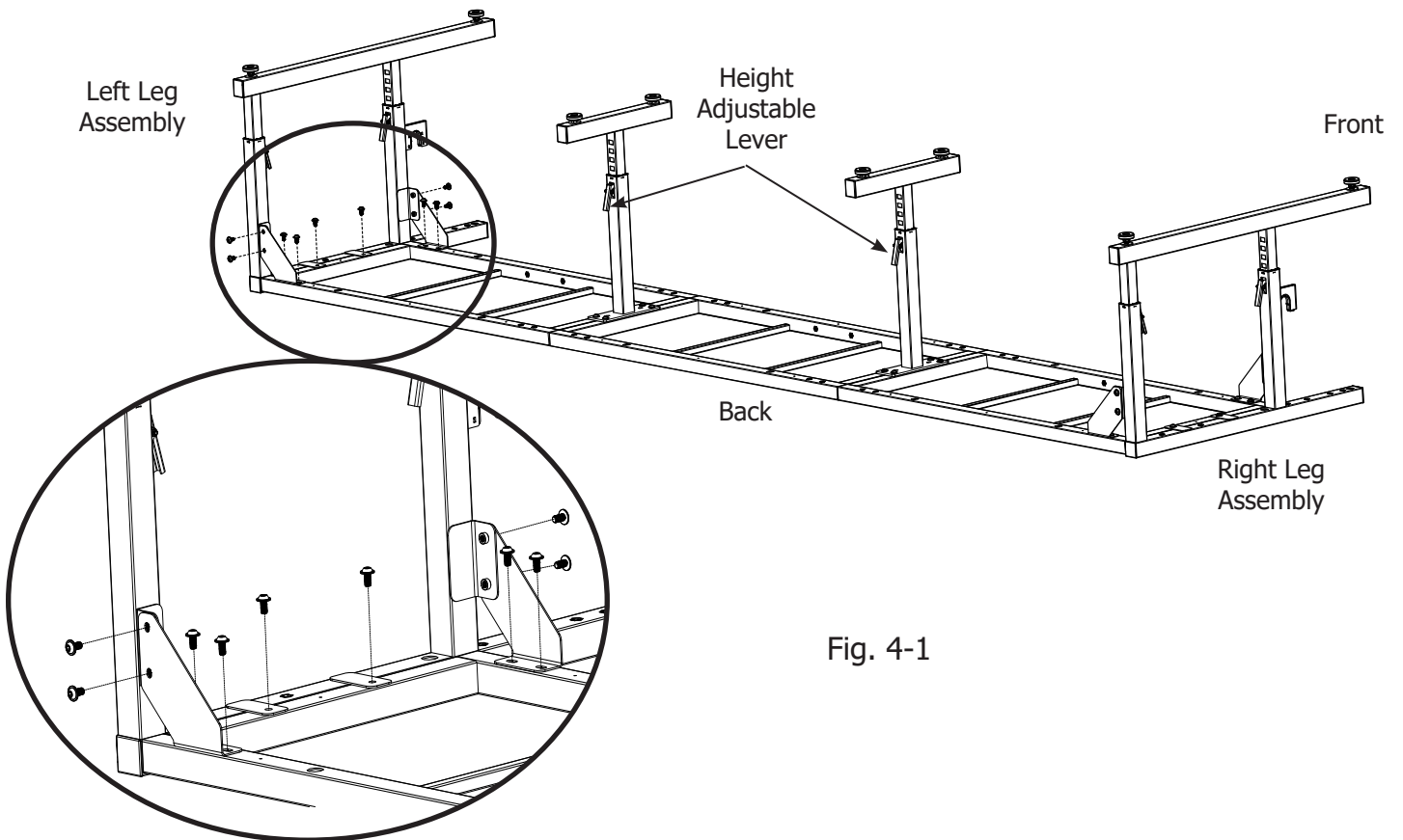

NOTE: Finger-tighten screws only until all screws are in place, they will be fully tightened **Step 4-6**.

Parts Needed

- 1 - table assembly
- 1 - right leg assembly
- 1 - left leg assembly
- 4 - corner braces
(two braces and two mirrored braces)
- 20 - M8 x 16mm SBHCS

Tools Required

- 5mm Hex Tool (provided)
- Spirit level (not provided)

4-1: Set the leg assembly at the lowest setting. With the table upside down, place the leg assembly at the end of the table assembly with the mounting tabs over the table top as shown.

4-2: Align the two holes in the mounting tabs with the table assembly and place two M8 X 16 SBHC screws into the table top. Finger tighten only for now.

Step 4: End Leg to Table Assembly (continued)



NOTE:

Make sure all height-adjustable legs are at their shortest setting before proceeding with **Step 4-6**.

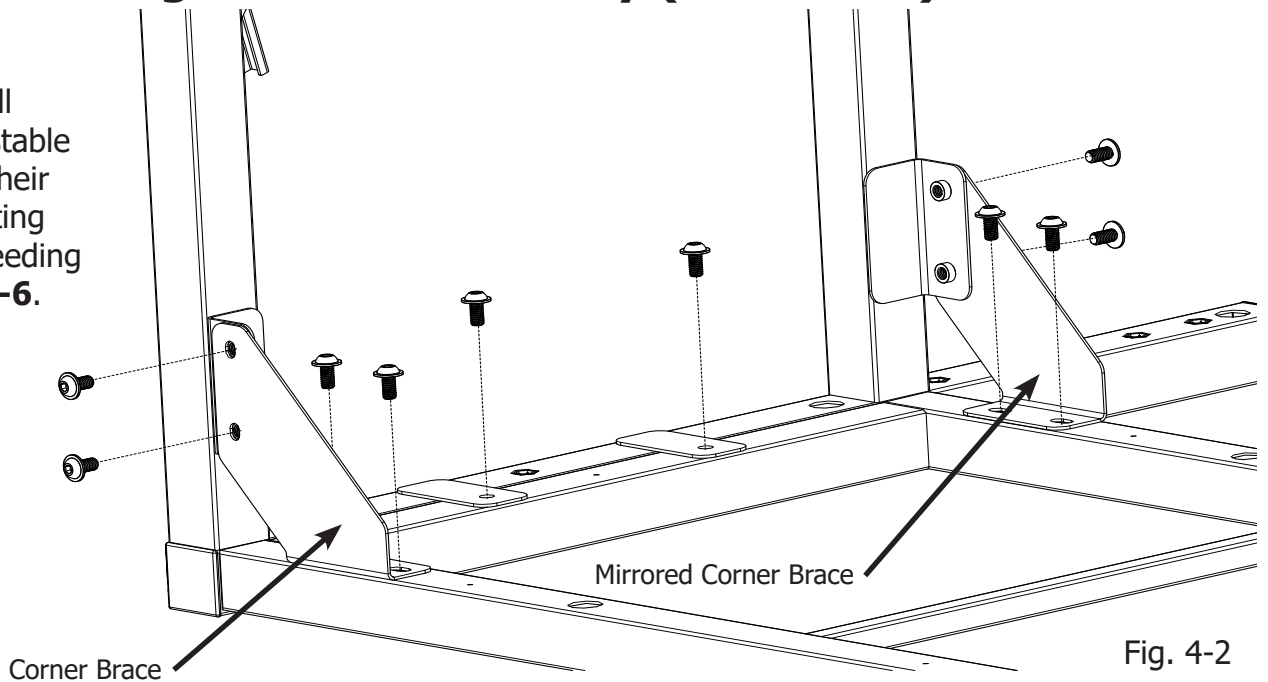

Fig. 4-2

4-3: Locate a corner brace and a mirrored corner brace. The corner braces should be positioned on the outside of the leg assembly tabs as shown. See (Fig. 4-2).

4-4: Align the holes in the corner brace with the table top and end leg and start an M8 X 16 SBHCS into each hole. Finger tighten only for now.

4-5: Push the leg assembly up tight against the table assembly to remove any gap and fully tighten the two tab screws into the table assembly.

4-6: Ensure the leg assembly is square to the table assembly and fully tighten the four screws on both corner braces.

4-7: Repeat **Steps 4-3** through **4-6** for the right leg assembly.

4-8: At this point, all screws should be tightened on the table. Double-check all M8 X 16mm screws to make sure they are tightened, using the 5mm hex tool.

4-9: With the help of a second person rotate the table so it is upright.

4-10: Using a spirit level, check and adjust the frame top to be level **in the location where the frame will be used**. Check the leveling in the front and back and both sides. Adjust the leveling feet if needed.

Double-check the table-top frame to ensure that it is flat at each table splice brace and not sagging or high at the joints. If no spirit level is available, check the table with the machine on the carriage and the Precision-Glide tracks after they have been installed **in Step 5**. Ideally, the machine will stay wherever it is placed and not roll left or right or to the front or back.

Step 5: Precision-Glide Track Assembly

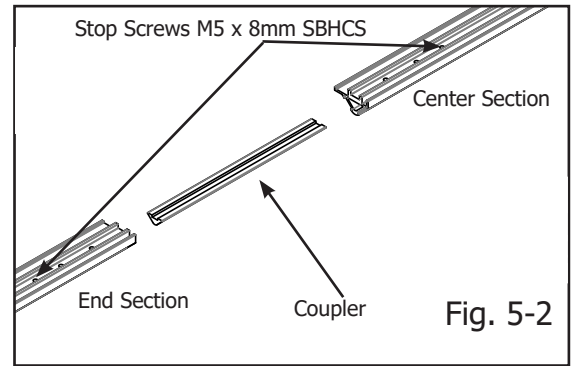
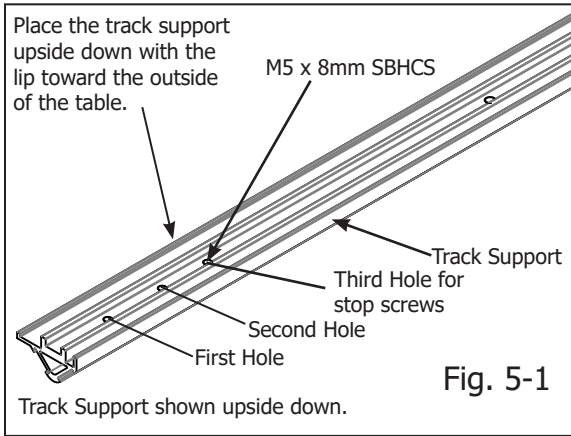

NOTE: The aluminum track support sections are cut from single sections of extruded aluminum and should align when placed end to end. However, if all directions in Step 5-4 are followed and track supports still do not align properly, try swapping track support sections, so that different ends are joining.

NOTE: If you cannot seem to get a joint between two track supports to align properly see pages 36 and 37 about the Track Alignment Kit.

Parts Needed

- 1 - table
- 6 - track supports
 - 12 foot: 6 four foot supports
 - 10 foot: 4 four foot & 2 two foot
- 4 - track support couplers
- 24 - M5 X 8mm SBHCS
- 12 - M6 connector screw with spacer assembly.
- 4 - 12' black plastic tracks
- 1 - Track Alignment Kit - only if needed, see note at bottom left. See pages 36, 37 for more info.

Tools Required

- 3mm Hex Tool (provided)
- 5mm Driver Hex Tool (provided)

5-1: Check inside the ends of the track supports for burrs or debris and remove all foreign matter from the inside.

5-2: Lay three track-support sections on the table upside down, with the wider lip of the sections facing toward the outside of the table (Fig. 5-1).

5-3: To prepare for joining one end and the center support sections together, screw one M5 X 8mm SBHCS into the third hole from each splice end of each section to serve as a stop screw (Fig. 5-1, Fig. 5-2). Fully tighten the screw with a 3mm hex tool. This

will help align the coupler properly into the two track support sections when joined together.

5-4: Insert a coupler into one prepared end of one track support section up to the stop screw. Thread an M5 X 8 mm SBHCS into the first hole and lightly tighten as shown in Fig. 5-2. Insert the other end of the coupler into second prepared track support section. Hold the two adjoining track support sections tightly together and thread an M5 X 8mm SBHCS into the first hole of the second track support and lightly tighten (shown in Fig. 5-2). You may need to gently rock the track support to seat the coupler. Finally, insert a second screw into the track supports, align and tighten.

5-5: Repeat **Steps 5-3** and **5-4** to join remaining track support section to center track support section to assemble one (1) track support. Once everything is aligned properly, tighten all screws firmly.

Step 5: Precision-Glide Track Assembly (continued)

 **NOTE:** The extrusions have a wider shoulder on one edge of the track. This shoulder is to be placed toward the inside of the table over the edge of the black plastic tabletop. (Fig. 5.4)

 **NOTE:** The track support surfaces must be perfectly aligned; otherwise, the quilter will feel a bump and quilting stitches will be adversely impacted.

 **NOTE:** for 10' frames the tracks will need to be scored and then snapped off at 10'.

5-6: Insert a plastic track completely into one side of the aluminum track supports. The plastic track should slide into the track support easily. If the plastic track binds slightly, try backing the track out a little, then pushing it further. If the plastic binds badly, check the track supports for debris, burrs, misalignment, or damage. (Fig. 5-3) In the same manner, insert plastic track in the other side of the track support.

5-7: Repeat **Steps 5-1** through **5-6** to make the second track.

5-8: Install Locking Retainer in track ends.

- Assemble the screw through the cap and into the wedge just enough to align the wedge into the cap without expanding the cap.
- Slide the locking retainer assembly into the end of the track extrusion and then tighten the screw firmly.
- Do not over tighten the screw.
- Repeat for the other three track extrusion ends.

(Fig. 5-5, 5-6, and 5-7.)

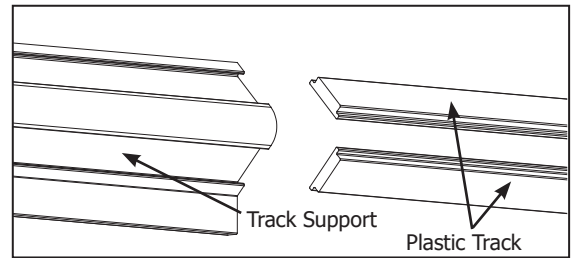

Fig. 5-3



Fig. 5-4

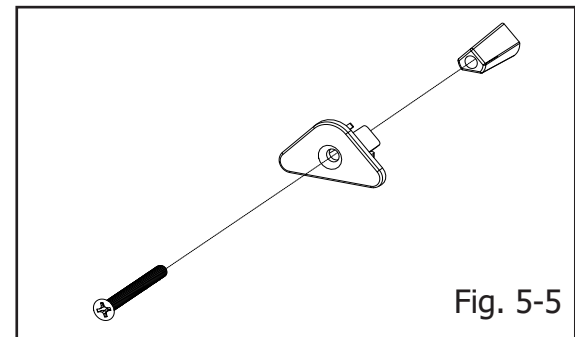

Fig. 5-5

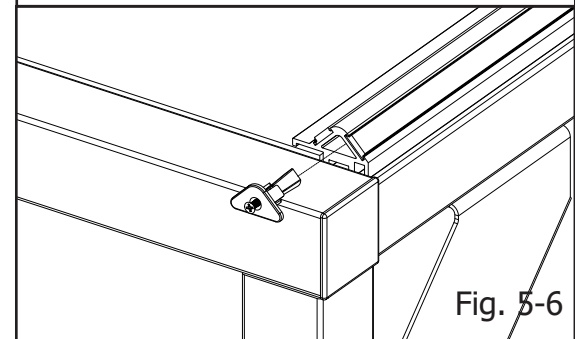

Fig. 5-6

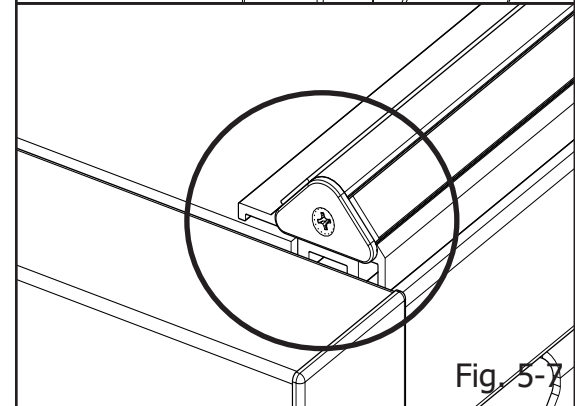

Fig. 5-7

Step 5: Precision-Glide Track Assembly (continued)

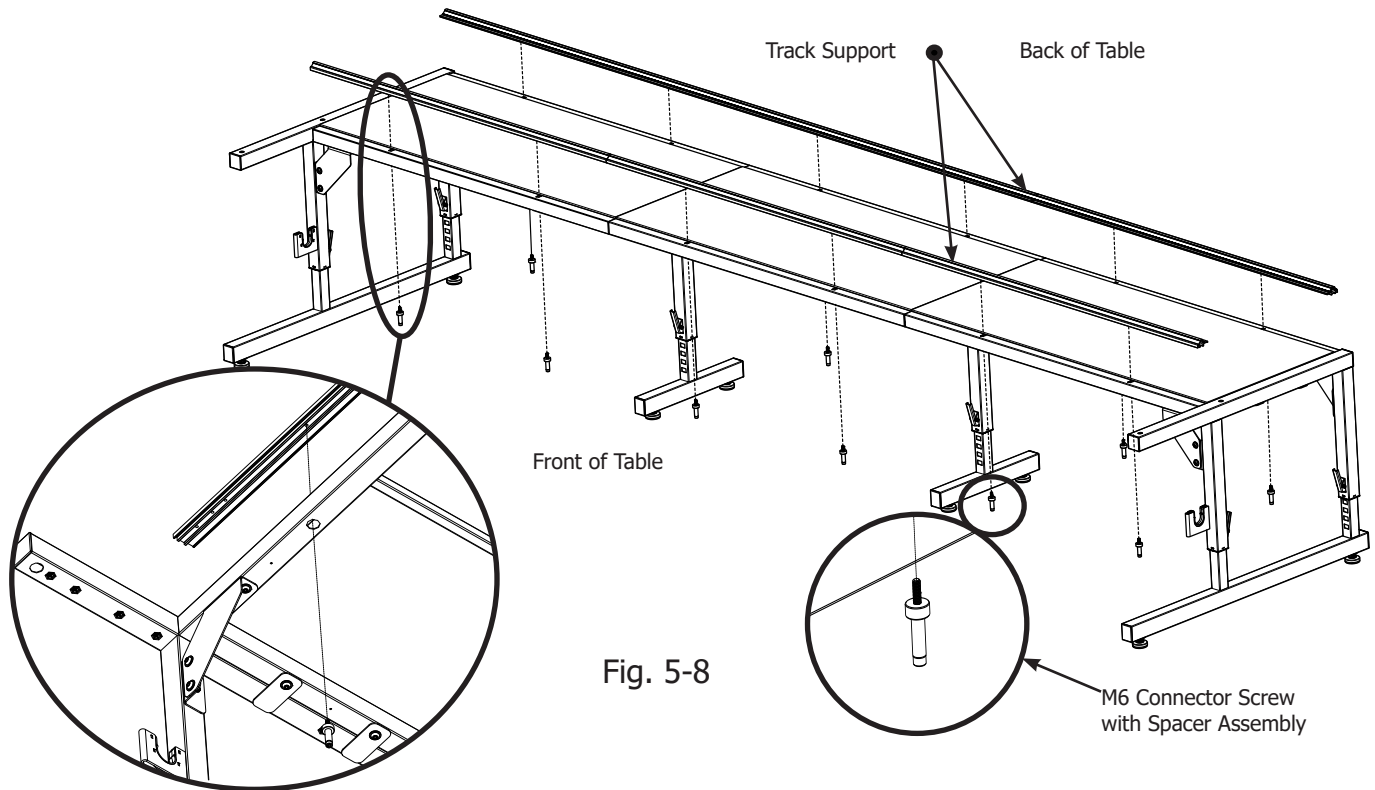

Fig. 5-8

5-9: Attach Tracks. Secure one assembled track to the back of the quilting frame. Line up the track support by holding it tightly against the plastic tabletop as you secure it to the frame using six (6) M6 connector screw with spacer, as shown in Fig. 5-8. **Do not tighten screws at this time.** They need to be loose to accommodate adjustments in **Step 5-10.** In same manner, attach the remaining track support to the front of the frame using six (6) M6 connector screw with spacer.

5-10: Align Tracks. Place the carriage on the tracks at one end of the table. Roll back and forth along the length of the table, establishing the distance between the two tracks, taking care to check that the wheels are engaging the track on both the front and the back of the carriage. Move both tracks in tandem to the back of table as far as possible. (Slots in the tables allow this movement.) Double-check that the back track is straight along the back edge of the table. Fully tighten the screws in the **BACK track only** for now with the 5mm driver hex tool.

5-11: Place the machine onto the carriage and again, roll it the entire length of the frame, working the tracks into the wheels as you go. With the machine and carriage over each screw area, lightly tighten the front track support screws as you move down the table. Check the carriage to verify that it rolls smoothly and that both ends of the carriage are engaging the tracks. If you find a section of track where the carriage rocks back and forth when moved all the way forward or back, loosen the front track support screws and adjust the front track until the carriage rolls smoothly and does not rock, then re-tighten the front-track screws.

5-12: Finally, fully tighten the front track to the table with the 5mm driver hex tool.



NOTE: If you feel a bump at the joint of the track supports, see the Troubleshooting section at the end of these instructions.

Step 6: Side Arm Height Tube Assembly

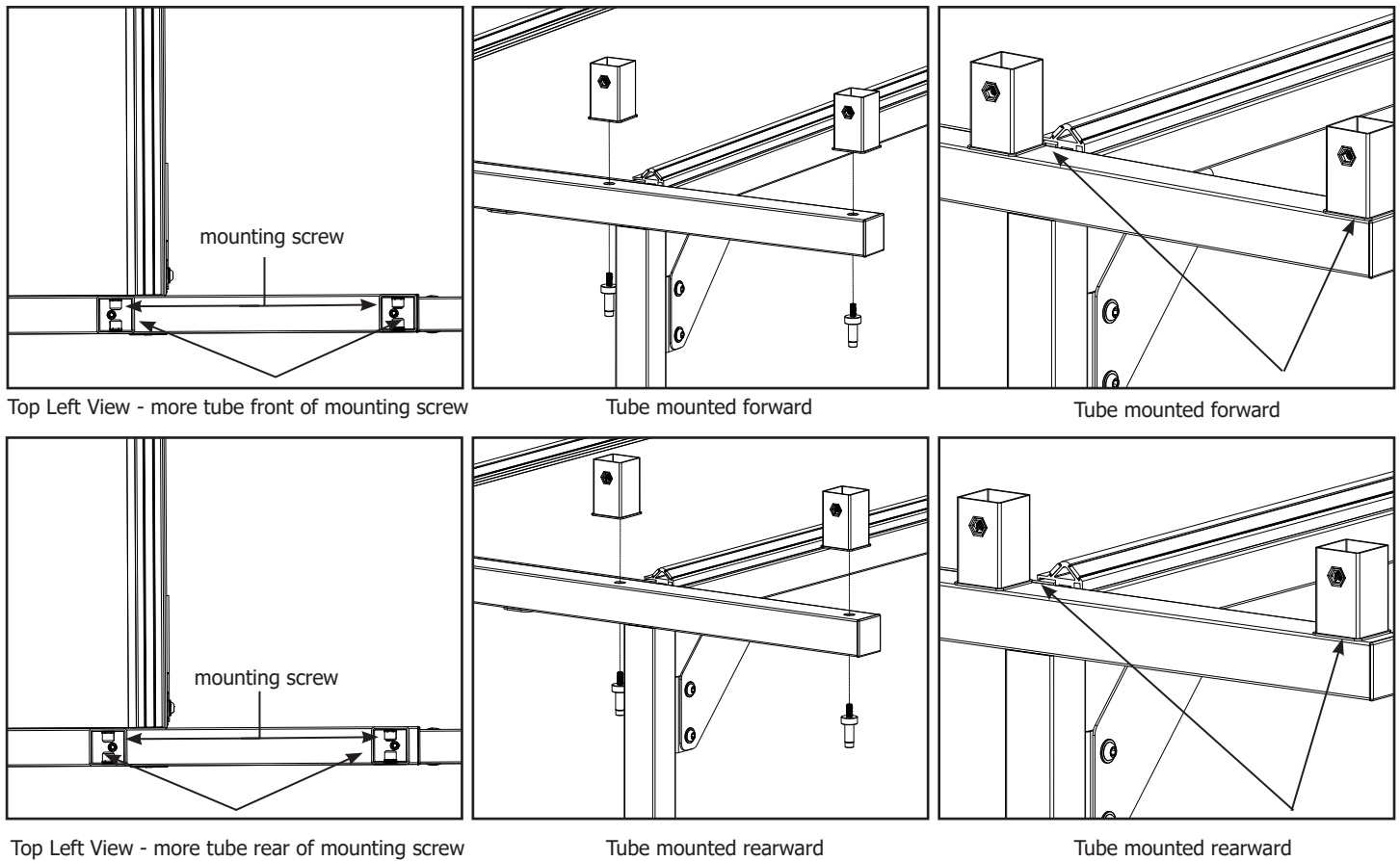



Fig. 6-1

Parts Needed

- 4 - side arm height tubes
- 4 - connector screw with spacer assembly

Tools Required

- 5mm Hex Tool, straight handle (provided)
- 5mm Hex Tool, L handle (provided)

 **NOTE:** Study the inside of the side arm height tubes to see that the mounting hole is offset, not centered. All four tubes must be mounted in the same configuration, rearward for the 20" machine and forward for the 16" and 18" machines. If one tube is mounted forward and the other side rearward the side arm assemblies will not fit onto the tubes and or not be aligned properly from one frame side to the other. It is critical that they be mounted correctly so the quilt will be straight on the frame.

6-1: The 20" machine has the height tube mounted rearward. The 16" and 18" machine have the height tube mounted forward.

6-2: Mount all four height tubes as stated above using an M6 screw with spacer. Check that the bottom of the height tube seats flat into the hole in the horizontal tube and tighten with the 5mm straight handle hex tool and then fully with the 5mm L hex tool.

Step 7: Connector Arm to Front Pole Side Arm Assembly

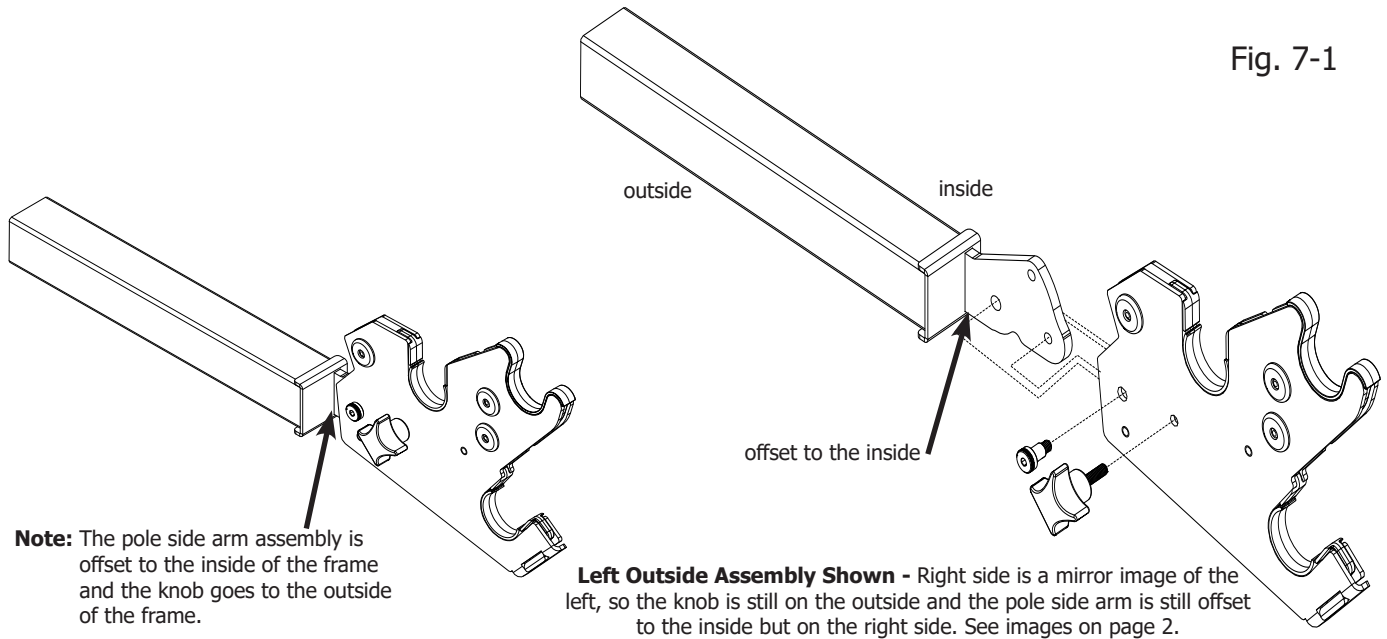

Parts Needed

- 1 - front right side arm assembly
- 1 - front left side arm assembly
- 1 - rear right side arm assembly
- 1 - rear left side arm assembly
- 1 - connector arm right
- 1 - connector arm left
- 2 - shoulder screws (8MMx10 SHLD M6 THRD)
- 2 - knob

Tools Required

- 4mm Hex Tool (provided)

NOTE: Normally the left pole side arm assemblies (front and back) have plugs in them from the factory. The right side comes without plugs for the latches to be installed into later on.

IMPORTANT: For more information on how to decide whether you want the handwheel and latches to be on the right or left of the frame see **Step 9**.

7-1: Identify the front left side arm assembly and the left connector arm.

7-2: Slide the connector arm plate with three holes into the front side arm. Align the connector plate rear hole with the rear hole inside the front side arm assembly. Carefully start the shoulder screw into the captive nut in the far side of the front side arm assembly.

NOTE: You may need to wiggle the connector arm as you tighten the screw so the screw will pass all the way through the connector plate and tighten fully into the captive nut in the front side arm assembly.

7-3: The front side arm assembly can be moved into two positions, one up and one down. The knob threads into a captive nut in the front side arm assembly holding it into position. When the assembly is on the correct side of the frame, the knob will be on the outside.

7-4: Repeat steps 7-1 through 7-3 for the front right side arm assembly. **IMPORTANT:** Make sure the right side is set the same as the left side, either up or down but not mixed.

Step 8: Rear Pole Side Arm to Frame Assembly

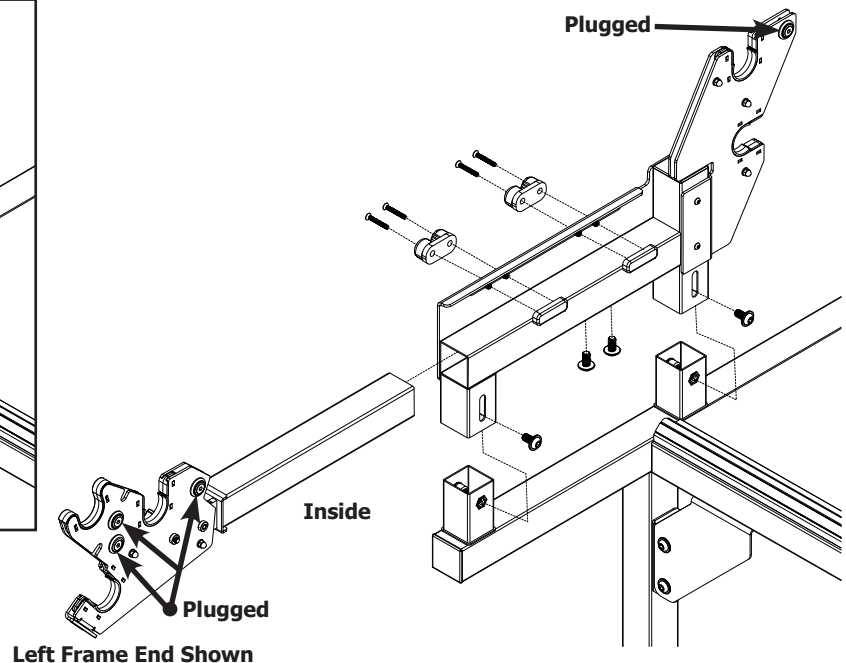
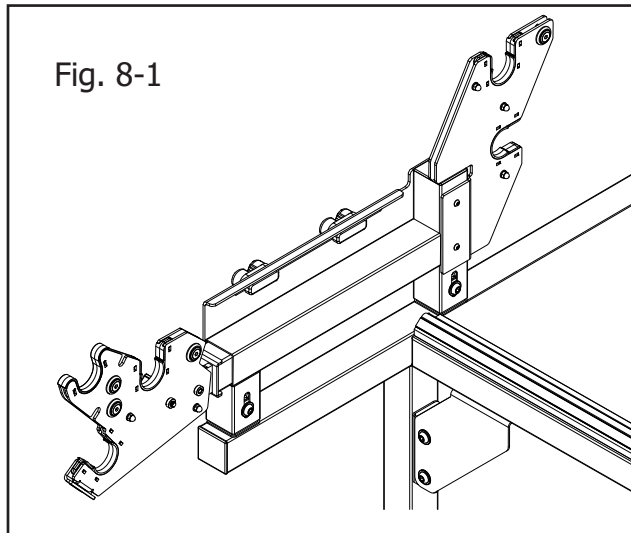



Parts Needed

- 1 - front left connecting arm assy
- 1 - front right connecting arm assy
- 1 - rear left pole side arm assy
- 1 - rear right pole side arm assy
- 8 - screw, M8 X 16
- 2 - knob
- 4 - screws, M6 connector screw with spacer
- 2 - Bungee Grabber™ Assemblies

Tools Required

- 5mm Hex Tool (provided)
- #2 Phillips Screwdriver (not provided)

 **NOTE:** Normally, the left pole side arm assemblies (front and back) have plugs in them from the factory. The handwheel and latch assemblies go on the unplugged frame end where you want your handwheel and ratchet assemblies.

 **IMPORTANT:** For more information on how to decide whether the unplugged pole bracket will be on the right or left of the frame see **Step 9**.

8-1: Identify the left (plugged) and right (unplugged) rear side arms and the left (plugged) and right (unplugged) front side arm with connector arm assemblies.

8-2: Lower the left rear plugged side arm onto the height tubes and place a M8 X 16 screw thru the two elongated slots into the height tubes. Set the assembly at the lowest setting for now and lightly tighten the two screws. (The final height setting will be done once the machine is on the carriage and on the tracks. See Step 16.)

8-3: Slide the left front plugged side arm assembly with connecting arm all the way into the rear side arm for now. Place a M8 X 16 screw up into the two captive nuts under the arm and lightly tighten the screws. (The final front to back setting will be done once the machine is on the carriage on the tracks, see Step 16.)

8-4: Attach the two Bungee Grabber assemblies by placing a mounting screw through the assembly, the outside of the side arm bracket, and into the mounting plate. Slide the assemblies to the desired positions and fully tighten the screws with a #2 Phillips screwdriver.

8-5: Repeat steps 8-1 through 8-4 for right side unplugged pole bracket assemblies.

Step 9: Ratchet-Stop Assembly

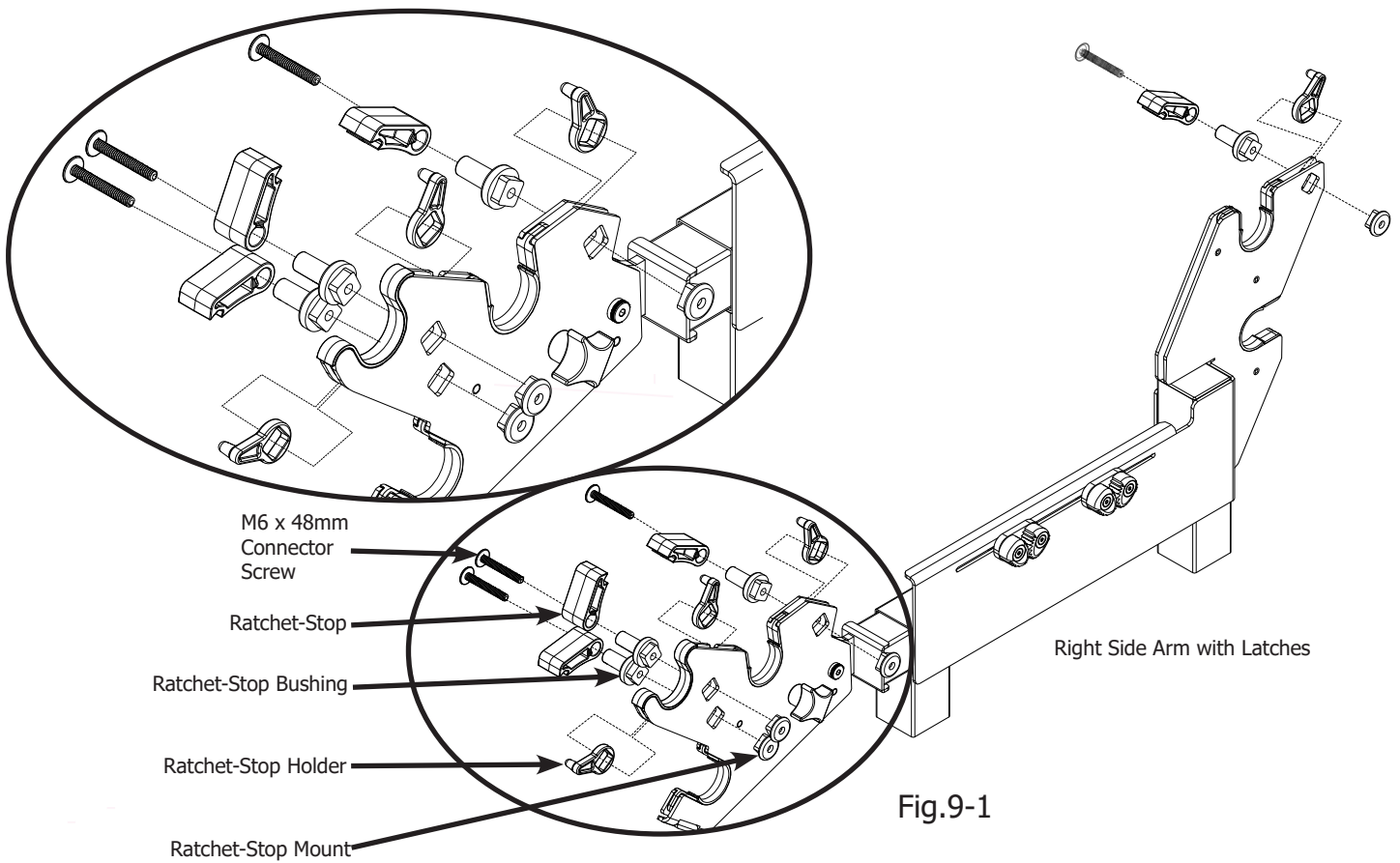

Parts Needed

- 1 - unplugged pole bracket assembly
- 4 - M6 x 48mm connector screw
- 4 - ratchet-stop
- 4 - ratchet-stop bushing
- 4 - ratchet-stop mount
- 4 - ratchet-stop holder

Tools Required

- 4mm Hex Tool (provided)

9-1: Decide whether you want the ratchets and handwheel to be on the left or the right side of the frame. The following instructions show how to assemble the frame with the handwheel on the right side of the frame, which is the most common setup. If you prefer the handwheel to be on the left side of the frame, see “Left Side Option” on the next page.

9-2: The right side arms (front and rear) come unplugged ready for the ratchet stops.

 **NOTE:** The instructions that follow assume that the unplugged side arm, latches, and handwheel will be used on the right side of the frame.

9-3: Place one ratchet-stop holder between the two metal pieces at the back of the unplugged pole bracket, with the stop nub facing inside, as shown in Fig.9-1.

9-4: Following the parts order in the circled detail in Fig. 9-1, thread one M6 x 48mm connector screw through a ratchet stop, ratchet-stop bushing, pole bracket (with ratchet-stop holder inserted) and finally into the ratchet-stop mount. Pay close attention to the orientation of the ratchet stop. Tighten with the 4mm hex tool until the ratchet-stop holder nub holds the ratchet stop.

9-5: In same manner, attach the remaining ratchet stops and ratchet-stop holders to the front of the pole bracket, paying attention to the orientation of the ratchet stops (Fig. 9-1) to create the right pole bracket.

Step 9: Ratchet-Stop Assembly (continued)

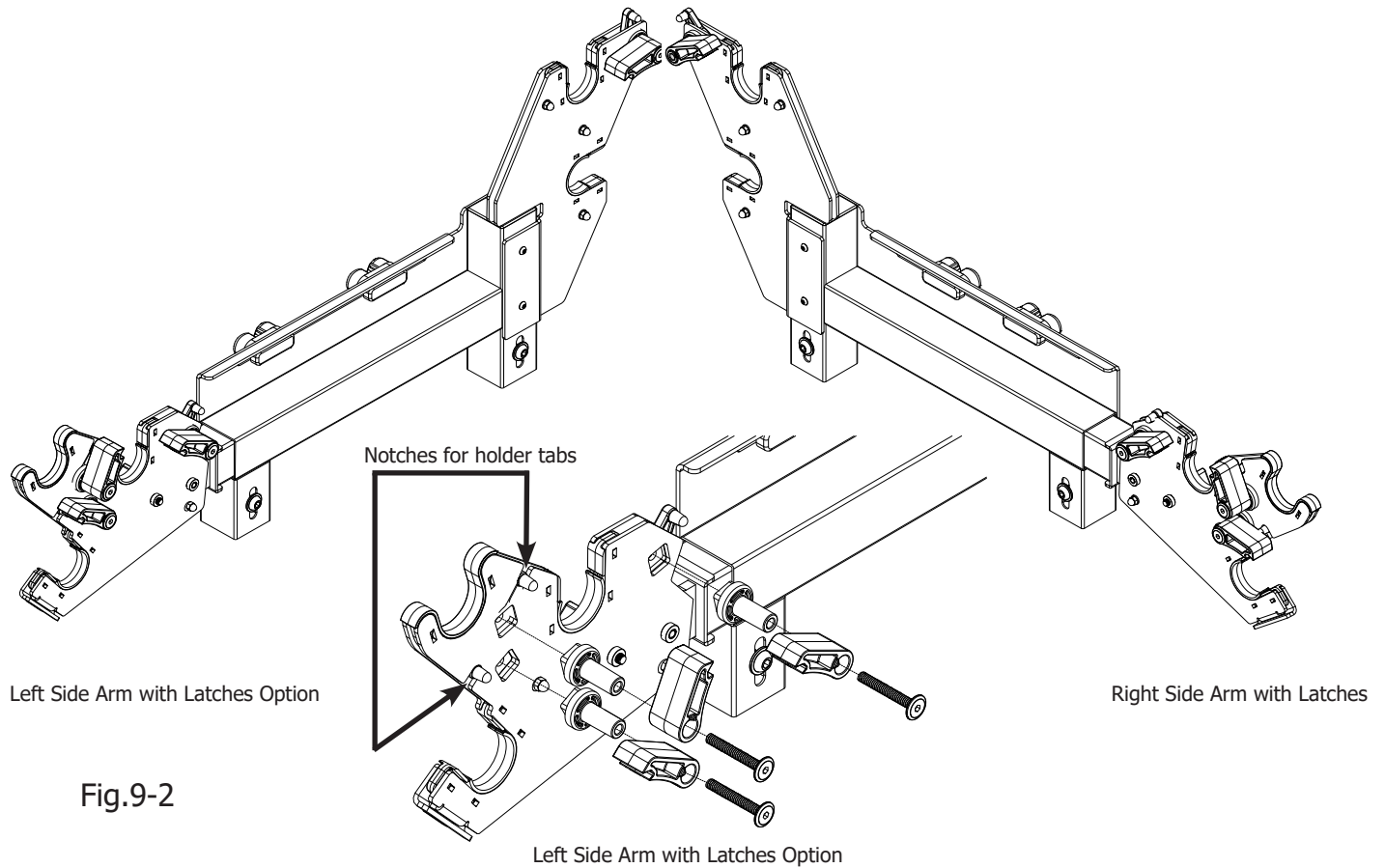

Left Side Option

If assembling with the handwheel and ratchets on the left side, remember that the ratchet stops and the ratchet-stop holder nubs go to the inside of the pole bracket when it is attached to the table. You will first need to remove the plugs in left side arm and install them into the right side arm. Keeping this in mind, follow **Steps 9-2** through **9-5** to assemble the left pole bracket, reversing the direction of the ratchet-stop, ratchet-stop bushing, ratchet-stop holder and ratchet-stop mount shown in Fig. 9-1.

Step 10: Pole Coupler Assembly

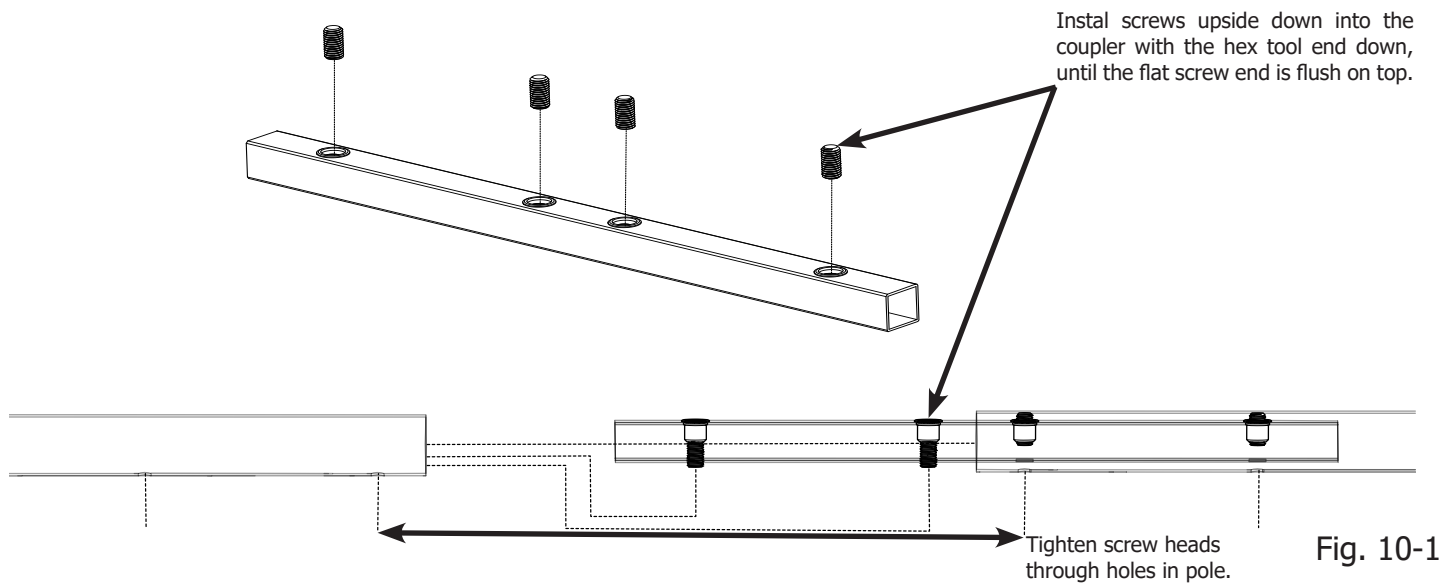

IMPORTANT: Be careful not to pinch your hands between pole parts while sliding them together.

NOTE: Your frame comes with 15 pole sections, which enable you to create 5 completed pole assemblies (the 4-foot size uses five pole sections, 8-foot uses 10 pole sections and 5 couplers, and the 12-foot uses all 15 pole sections and all 10 couplers).

NOTE: If you are assembling a four-foot (4-foot) frame, you may skip **Step 10** and proceed to **Step 11**.

NOTE: 10-foot frame uses 10 four-foot pole sections and 5 two-foot pole sections. The two-foot sections go in the center.

Parts Needed for 12' Frame

15 pole sections
10 pole couplers
40 Screws-M10 X 20 SKS

Tools Required

5mm Hex Tool (provided)

10-1 Prepare the pole couplers by installing four screws upside down into the coupler with the hex tool end down, until the flat screw end is flush as shown in Figure 10-1.

10-2: Join two 4-foot pole sections together by inserting a pole coupler into the end of one pole section half way until the coupler screws align with the holes in the pole. Lightly tighten the two coupler screws to hold it into place.

10-3: Slide the next pole onto the coupler until it touches the first pole without any gap. Lightly tighten the screws in the second pole. Check for gap between the poles and that the poles are straight and then fully tighten all four coupler screws.

10-4: In same manner, add final 4-foot pole section to section completed in **Step 10-3** to complete one 12-foot pole assembly.

10-5: Using remaining couplers and pole sections, repeat **Steps 10-2** through **10-4** to complete four more 12-foot pole assemblies for a total of 5 pole assemblies.

Step 11: Pole End Assembly

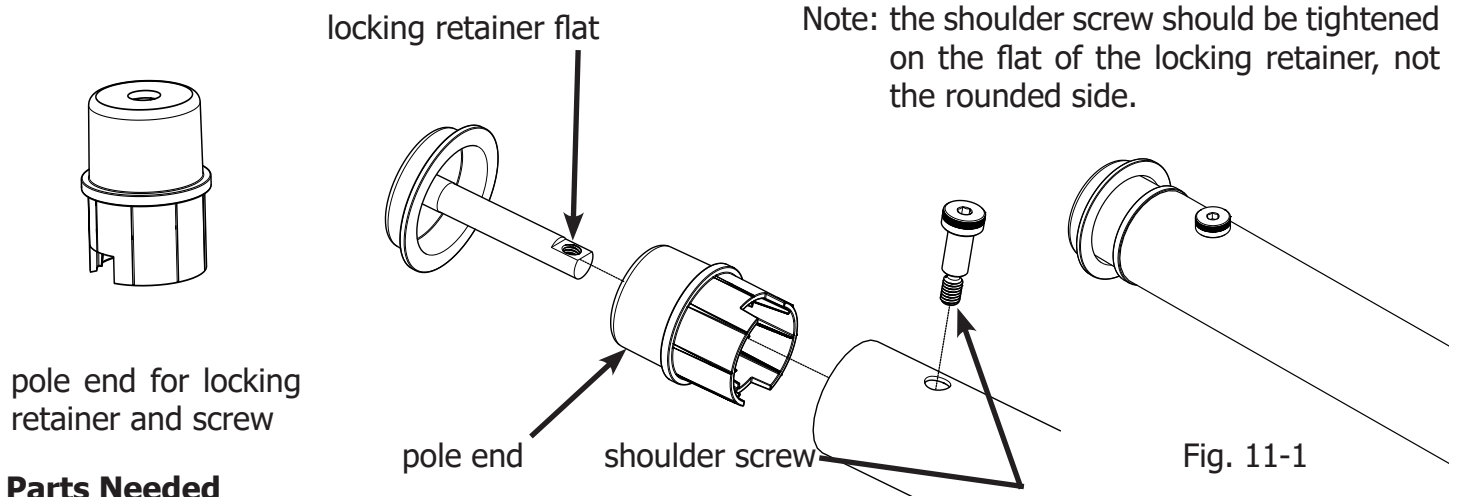

Parts Needed

- 5 - pole assemblies
- 4 - retainer pole end
- 5 - pole ends
- 5 - locking retainers
- 5 - shoulder screw 8mmX16, 6mm thd
- 3 - ratchet wheels
- 2 - snap buttons
- 1 - handwheel assembly

Tools Required

- 4mm Hex Tool (provided)

NOTE: the ratchet and handwheel side of the frame will use the four retainer pole ends. The non ratchet side of the frame will use the pole ends with the locking retainers and shoulder screws.

Pole End Assembly

11-1: Place one pole end, one locking retainer, and one shoulder screw (Figure 11-1) on one end of all five pole assemblies. The screw should tighten down on the flat of the locking retainer, not the round side.

11-2: Place a retainer pole end on the other end of one pole assembly to be used as the batting bar pole.

11-3: Repeat the previous step for the idler pole.

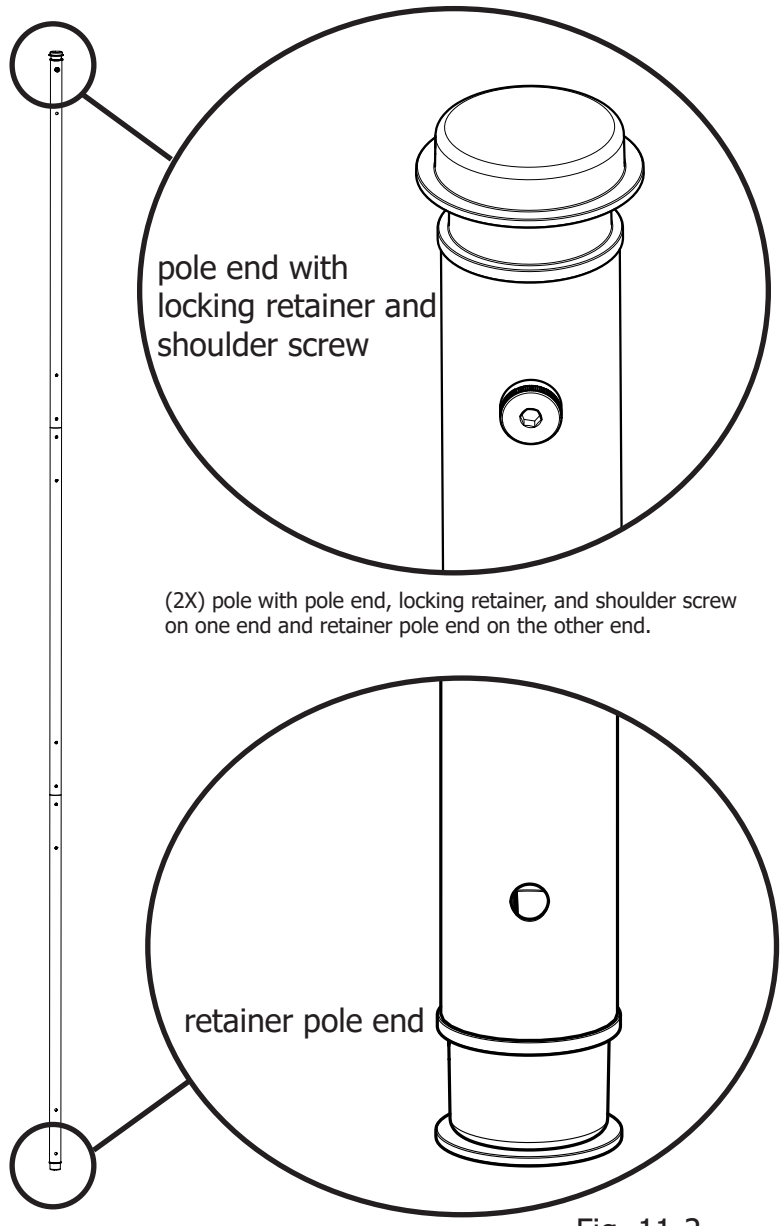

Step 11: Pole End Assembly (continued)

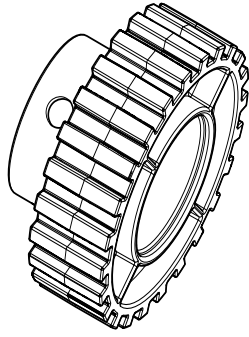

ratchet wheel

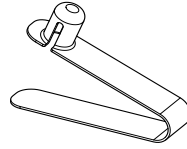

snap button

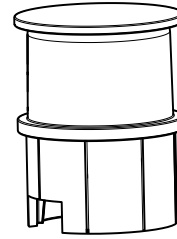

retainer pole end

Fig. 11-3

Ratchet Wheel Assembly

 **NOTE:** Two poles will have a ratchet wheel placed onto the pole before the retainer pole end. One will be the quilt top pole and the other will be the backing pole.

11-4: Place a snap button into a pole and then align it with the hole in a ratchet wheel. Slide the ratchet wheel flange end with small hole over the pole and let the snap button snap into the small hole on the ratchet wheel. The snap button keeps the ratchet wheel in position on the pole.

11-5: Locate the two notches in the pole end and ensure they are aligned properly to clear the snap button. Then push the pole end into the pole until it seats nicely against the ratchet wheel.

This end already has the pole end with locking retainer from step 11-1.

notches in retainer pole end for snap button

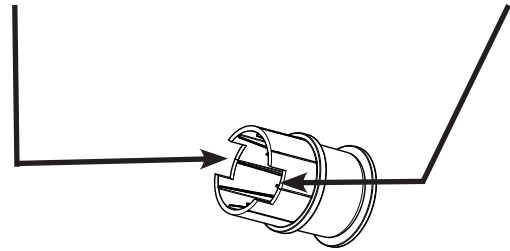

(2X) pole with ratchet wheel, retainer pole end on one end and pole end with locking retainer on the other end.

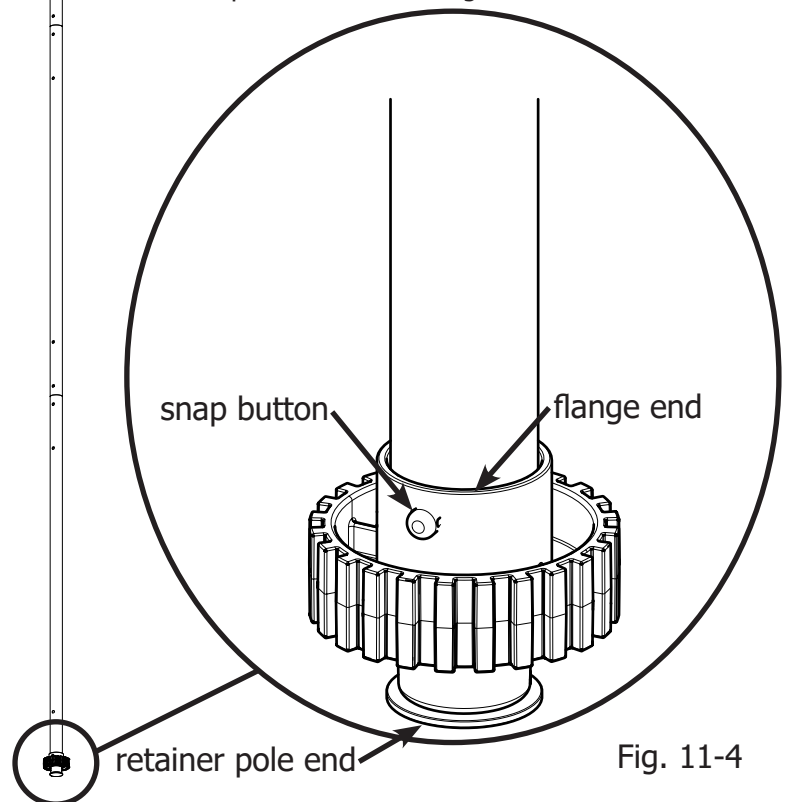
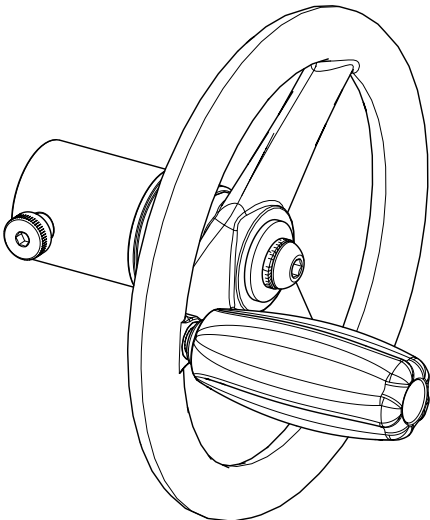
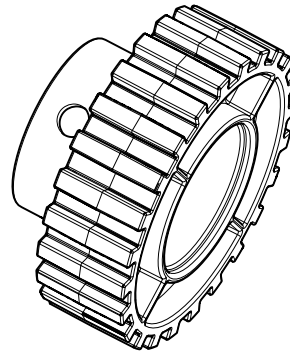

Fig. 11-4

Step 11: Pole End Assembly (continued)



handwheel assembly



ratchet wheel

Fig. 11-5

Handwheel with Ratchet Wheel Assembly

 **NOTE:** One pole will have a handwheel assembly with ratchet wheel. This will be the take-up pole. The pole insert for handwheel is part of the handwheel assembly and acts as the pole end in this case.

11-6: Slide the ratchet wheel onto the pole end flange first. Align the hole in the ratchet wheel with the hole in the pole.

11-7: Place the handwheel assembly into the pole end aligning the threaded hole in the pole insert for handwheel with the pole and ratchet wheel holes.

11-8: Insert an M8 X 10 Shoulder screw with 6mm threads and firmly tighten with a M4 hex tool. (Do not over-tighten.)

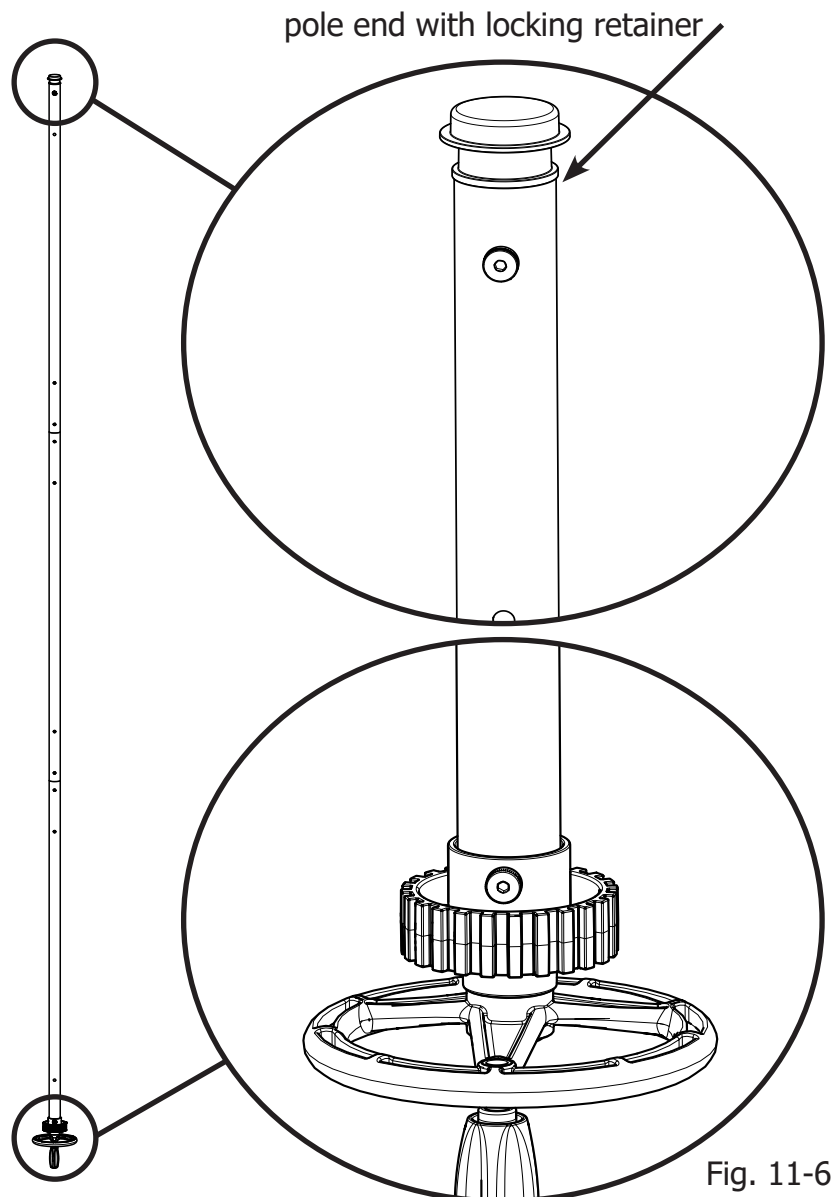

Fig. 11-6

Step 12: Pole to Frame Assembly

Parts Needed

- 1 - frame assembly
- 1 - backing pole (A)
- 1 - quilt-top pole (B)
- 1 - take-up pole (C)
- 1 - idler pole (D)
- 1 - batting storage pole (E)

12-1: Place the poles on the frame as shown in Fig. 12-1.

Note: the pole ends with locking retainers go on the side opposite of the handwheel and ratchets poles.

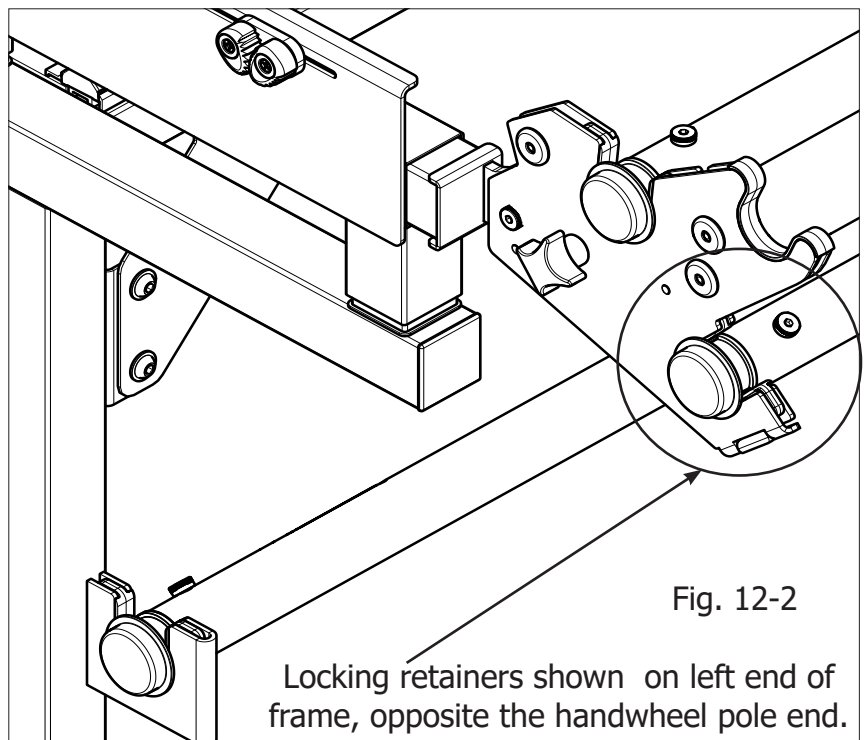
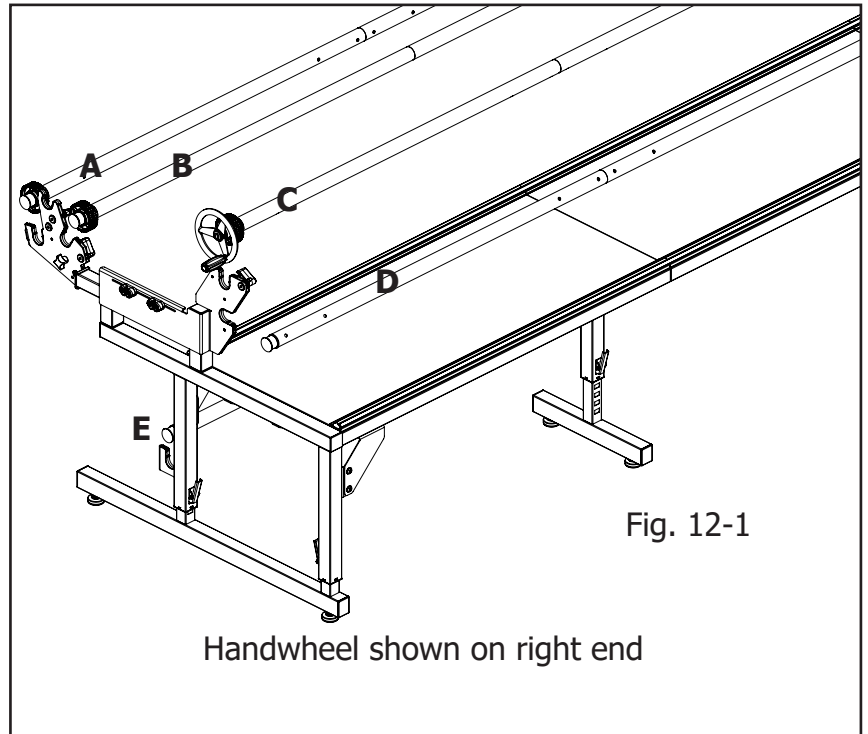

Step 13: Hook and Loop Strip Attachment

Parts Needed

- 1 - quilt-top pole
- 1 - backing pole
- 1 - take-up pole
- 3 - hook and loop strips

Tools Required

- measuring tape or ruler (not provided)
- scissors (not provided)
- permanent marker (not provided)

Apply Hook and Loop to pole assemblies

13-1: Locate the center of the pole from left to right and mark it with a permanent marker.

There should be three pieces of Velco.

13-2: Locate the center of the hook and loop and mark it with a permanent marker.

13-3: Hook and loop will be attached to 3 pole assemblies. The take-up pole, the backing pole, and the top pole. Working on one pole at a time, rotate the pole so that the holes are facing up.

13-4: Starting from the center and working your way out, adhere the hook and loop to the poles. Use the holes in the poles to keep the hook and loop strip straight, making sure you are placing the hook and loop to one side of the holes, not over them. Carefully cut the adhesive paper **backing** at the center of the hook and loop strip, leaving one side of the backing in place as you work on removing the other side and adhering the hook and loop to the pole. Expose the adhesive a little at a time as you work from the center to one end, adhering the hook and loop to the pole as straight as you can as you go. Repeat with the other side of the pole.

13-5: Repeat step 3 with the remaining 2 pole assemblies. You'll have 3 pole assemblies with hook and loop in total.



NOTE: If done as stated above, your hook and loop will be in one piece over the pole assemblies. If at any point you wish to disassemble the pole assemblies you will need to cut the hook and loops at the pole junctions in order to separate the poles.



NOTE: Take care to stick the hook and loop on straight. This step will determine how well your quilts load in the future. For best results use the holes in the pole as a guide when aligning the hook and loop strip.

Step 14: Attach Leaders

Parts Needed:

1- Leader Set

Attaching the leaders to the pole assemblies

Attach a leader to each of the 3 poles with the hook and loop attached. **High Position** or **Low Position**. (See the diagrams that follow.)

14-1: Fold each of the leaders in half and mark the centers with a permanent marker. Place a mark on both the hook and loop edge and the hemmed edge.

14-2: When attaching the leaders to the hook and loop on the pole assemblies, start by aligning the center of the leader with the center of the pole and work toward the ends, keeping the leader as straight as possible and aligning it with the hook and loop.

14-3: The leader on the take-up pole at the rear of the frame attaches at the front of the pole, wraps over the top of the pole, and waterfalls to the back. This is the same for both position settings.

14-4: The leaders wrap differently on the two front poles (top pole and backing pole) for the 2 different settings.

High Position: On the pole closest to the front (backing pole), attach the leader at the front of pole and wrap over the top of the pole so that it waterfalls to the back between the 2 poles.

Blue arrows represent the direction the fabric comes off the poles

HIGH POSITION LEADERS

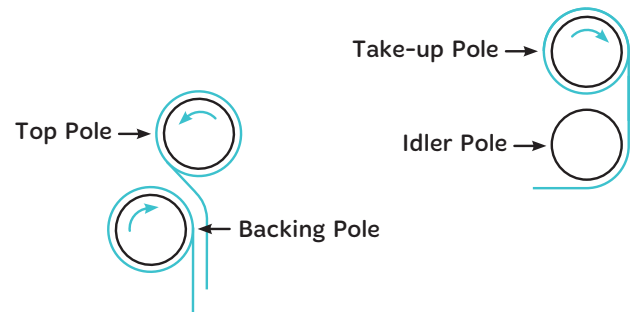

On the other pole (top pole) attach the leader at the rear of pole, wrap over the top of the pole so that it waterfalls to the front between the 2 poles.

Low Position: On the 2 front poles, attach the leader at the front of pole and wrap over the top of the pole so that it waterfalls to the back.

LOW POSITION LEADERS

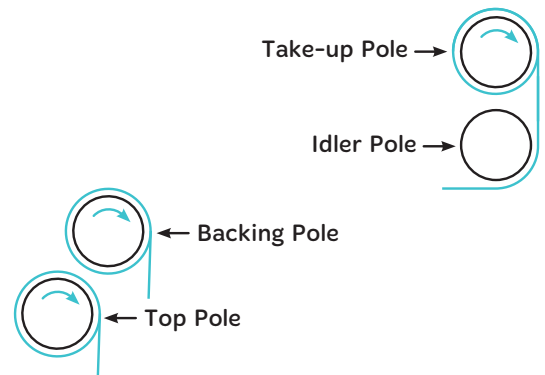

Step 15: Adjusting Side Arm Pole Bracket Position/Mode

This frame allows you to choose the loading method you prefer. You can choose which configuration you want to use for each quilt. **But keep in mind, you cannot change loading configuration once you have started quilting.** Position 1 provides a visual reminder of the actual quilting space and easy access to the bobbin area for oiling and bobbin changing. Position 2 is an option that allows for easy use of longer or larger templates or rulers.

Position 1, High Position

Start by putting the poles in the correct position for Position 1, upper position.

15-1: Grasp the pole bracket assembly under the bottom pole at the front. Remove the black knob from the outside of the side arm pole bracket. Raise the front of the side arm assembly and place the knob into the upper hole. Re-tighten the knob. Do this on both the left and right end of the frame.

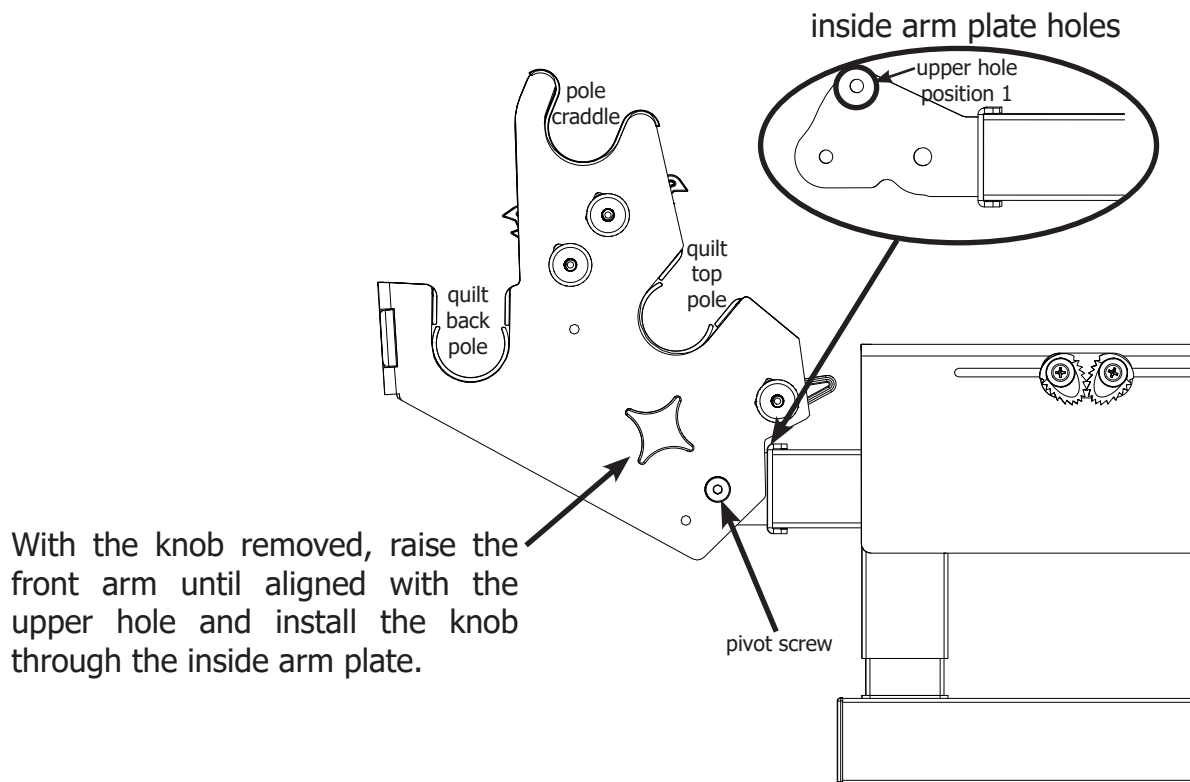

The pole closest to you is for loading the backing fabric. Use the ratchet stop closest to the front of the frame for the backing pole.

The pole closest to the back of the frame is for loading the quilt top. You will use the middle ratchet-stop on the top pole for this type of loading.

Step 15: Adjusting Side Arm Pole Bracket Position/Mode - Continued

Once you have the poles in the correct position, disengage the ratchet-stops and completely unroll the leaders from each pole. Engage the correct ratchet-stop and roll up the leader. The ratchet stop will only let you wind in the correct direction and will ensure the leader is wrapped correctly on each pole. For Position 1, the leaders should be wrapped around the poles so that they come over the tops of the poles and fall between the poles.

Always engage the ratchet stop when loading your quilt so that you can be assured you are winding in the correct direction.

High Position Setting: The bottom edge of the quilt top is loaded on the highest front pole. The bottom of this pole is level with the bottom of the idler pole. The quilt top fabric will come under the pole and stretch toward the back of the frame and basted to the backing and batting already in place. The quilt backing will be loaded on the front pole closest to the front of the frame. The backing fabric will come over the backing pole and under the top pole and stretch toward the back of the frame, going under the idler pole to the take-up pole. This configuration allows for easy access to the bobbin area of the machine. If you will not use rulers for quilting you should choose this setting.

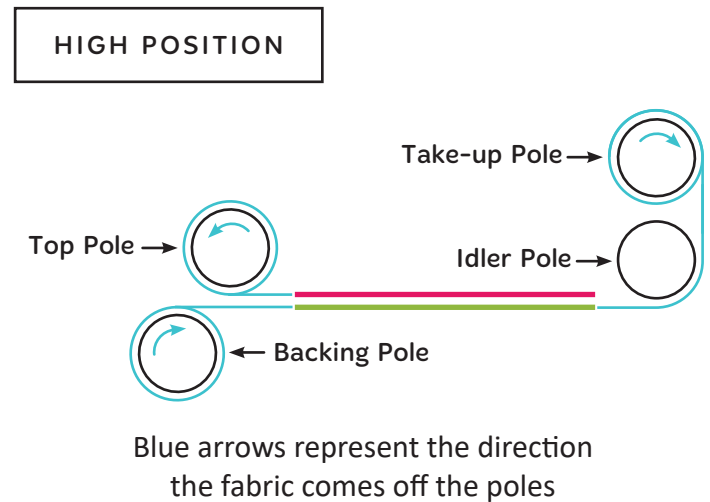

Step 15: Adjusting Side Arm Pole Bracket Position/Mode - Continued

Position 2, Low Position

Start by putting the poles in the correct position for Position 2, down position.

15-2: Grasp the pole bracket assembly under the bottom pole at the front. Remove the black knob from the outside of the side arm pole bracket. Lower the front of the side arm assembly and place the knob into the lower hole. Re-tighten the knob. Do this on both the left and right end of the frame.

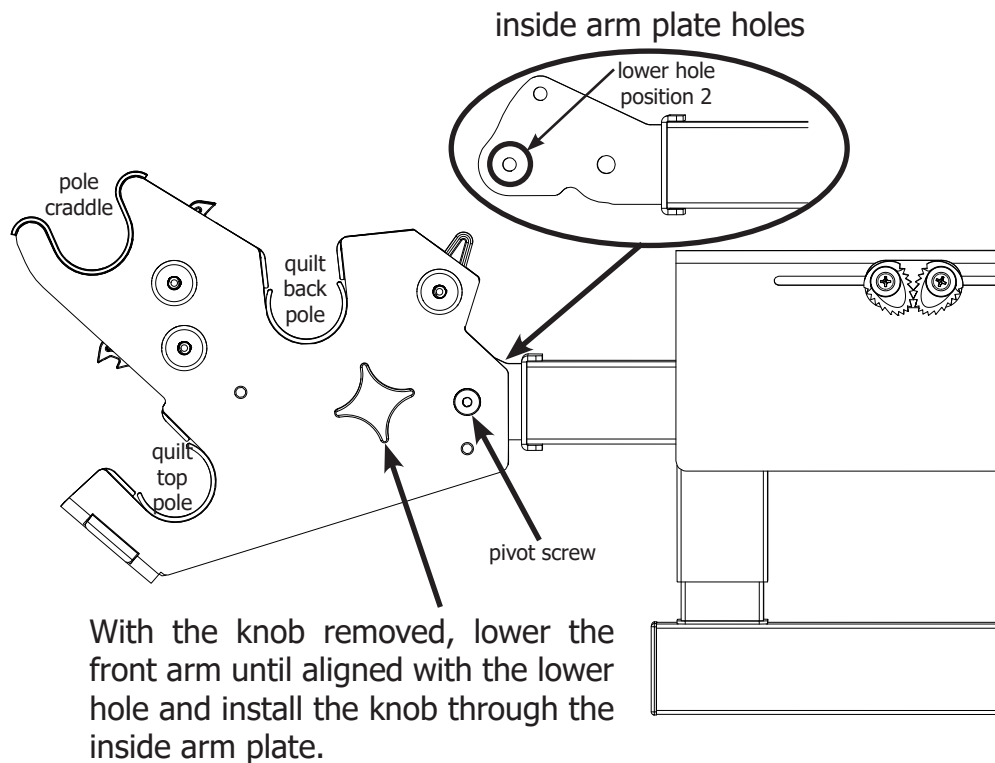

The bottom pole will be the pole on which you load the quilt top. This pole will use the ratchet stop closest to the front.

The top pole will be the pole you use for the backing. This pole will use the ratchet-stop furthest from the front for Position 2.

Once you have the poles in the correct position, disengage the ratchet stops and completely unroll the leaders from each pole. Engage the correct ratchet stop and roll up the leader. The ratchet stop will only let you wind in the correct direction and will ensure the leader is wrapped correctly on each pole.

Always engage the ratchet stop when loading your quilt so that you can be assured you are winding in the correct direction.

Step 15: Adjusting Side Arm Pole Bracket Position/Mode - Continued

Once you have the poles in the correct position, disengage the ratchet stops and completely unroll the leaders from each pole. Engage the correct ratchet stop and roll up the leader. The ratchet stop will only let you wind in the correct direction and will ensure the leader is wrapped correctly on each pole.

Always engage the ratchet stop when loading your quilt so that you can be assured you are winding in the correct direction.

Low Position Setting: The quilt backing is loaded on the highest front pole. The top of this pole is level with the bottom of the idler pole. The quilt backing fabric will come over the pole and stretch toward the back of the frame, going under the idler pole to the take-up pole. The quilt top will be loaded on the lower front pole, coming over the top of the pole and over the backing pole, stretching toward the back of the frame and basted to the backing and batting already in place. This is a good configuration when using larger rulers or templates while quilting. If you plan to use rulers for quilting you can choose either setting, however, the low position setting will make using larger rulers easier.

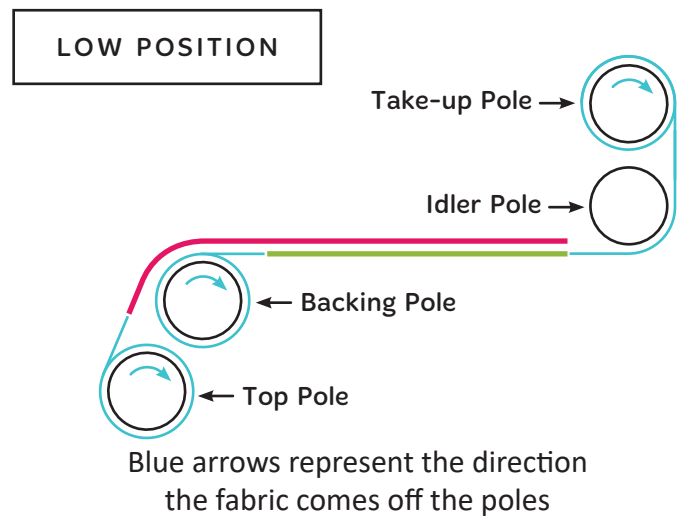

Step 16: Adjusting Side Arm Pole Bracket Height and Length

The side arm pole brackets will be adjusted for the following desired results:

- unrestrained movement
- maximum quilting area
- safe quilting area

Parts Needed

- 1 - assembled frame
- 1 - machine
- 1 - carriage

Tools Required

- measuring tape or ruler (not provided)
- 5mm L hex tool
- 5mm driver hex tool

 **NOTE:** Before attempting to adjust the side arm pole brackets, make sure the frame is level and that the machine and carriage stay where you place them, front to back or left to right. Check this at each end, center, and the entire length of the frame.

16-1: Place the carriage and machine on the frame. Roll the machine all the way to the front and all the way to the back to ensure it does not rock and that it rolls freely. Roll the machine and carriage left to right all the way to the end to make sure it rolls freely. Adjust the track assemblies if necessary. **See Step 5.**

16-2: Check that the frame is level and that the machine and carriage stay wherever they are placed, front to back and left to right.

16-3: Roll the machine and carriage to one end of the frame. Using a 5mm hex tool adjust the height of the pole side arm assemblies so there is about 1/2" (3/8" to 3/4") clearance between the bottom of the pole and the machine surface.

 **NOTE:** The front and back of the side arm assembly should be the same height, level, and not at an angle.

16-4: Repeat **Step 16-3** at the other end of the frame. Set the height and clearance the same as on the other frame end.

16-5: Roll the machine and carriage to the center of the frame and check the pole clearance while rotating the pole 360° to make sure the pole clears the machine.

 **NOTE:** if the frame top is level and the front and back of the side arm assembly is adjusted the same height then the assembly will also be level.

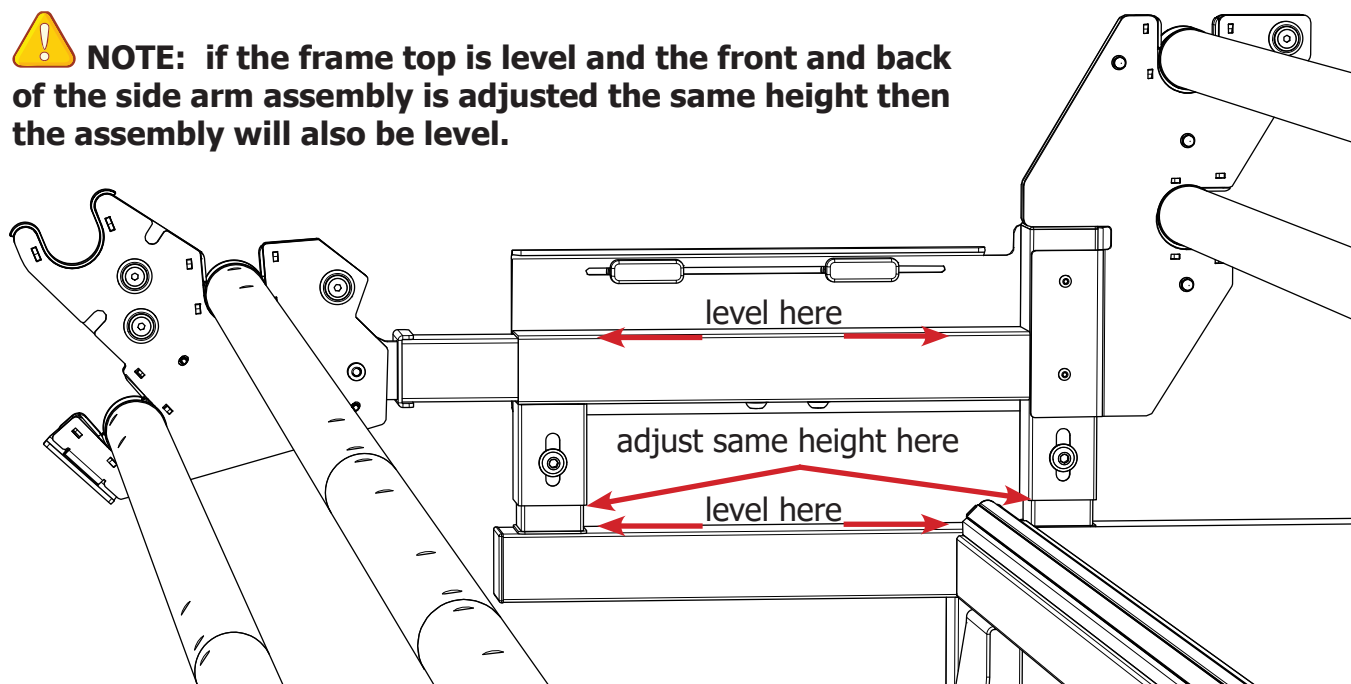

Step 16: Adjusting Side Arm Pole Bracket Height and Length - Continued

16-6: Determine the following:

- Position 1 (up) or Position 2 (down) mode
- With or without ruler base. If using the ruler base, install it now.

For more information about Position 1 and Position 2, see **Step 15**.

16-7: Loosen the two screws under the pole side arm as shown on one end of the frame and adjust the arm in or out as desired to clear the front pole, clear the ruler base, and give maximum machine movement.

16-8: Repeat Step **16-7** on the other end of the frame.

 **NOTE: It is IMPORTANT** that the pole side arms be adjusted the same on the left and right frame ends so the quilt will be straight. Measure to be sure they are set the same on both frame ends.

 **NOTE: IMPORTANT** Ensure the machine stops at a pole at the front, at the rear, or at the carriage end caps before the needle bar or needle bar head frame support can hit a pole.

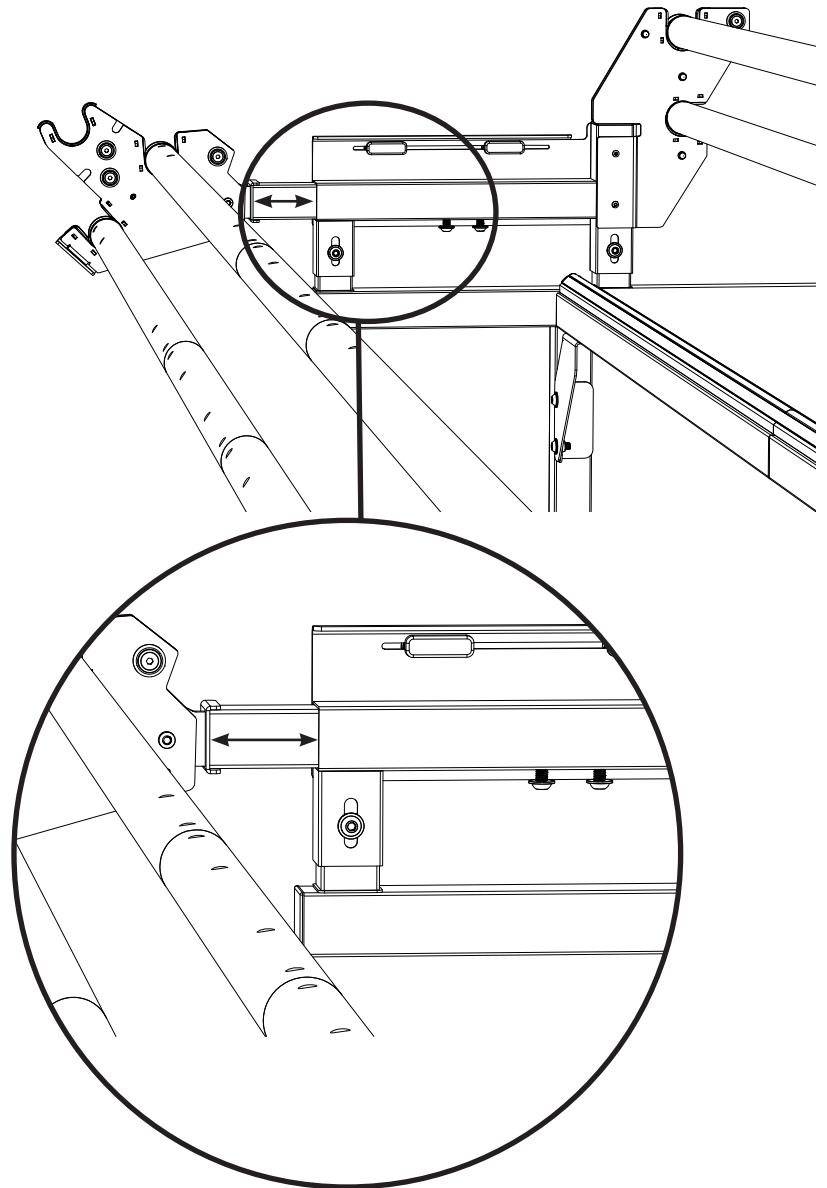

Step 17: Bungee Clamp Assembly

Parts Needed

- 1 - frame assembly
- 4 - bungee clamps

17-1: Drape the bungee cord over the bracket and down into the clamp as shown (Figure 17-1).

17-2: Follow **Step 17-1** for the other three bungee clamps.

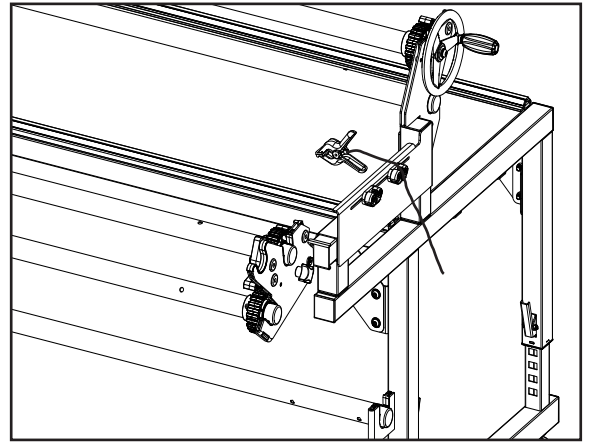

Fig. 17-1

Step 18: Adjusting Frame Height



NOTE: It is easier to raise the frame height than to lower the frame because the legs will ratchet up when lifted. To lower the frame, a second person will be needed to release the two latches on each leg while the other lifts the frame. This is why the frame was assembled at the lowest height setting.

18-1: The frame can be all the way down with no slots showing on the legs or raised in increments up to where nine sets of slots are showing. Most quilters will have three to six sets of slots showing when the height is set comfortably for them.

18-2: Adjust the frame height so that when standing at the front of the machine with your hands on the front handle bars, your elbows are bent at a 90 degree angle. It is recommended that you raise the frame one or two slots at a time until you reach your desired height setting as described in **Steps 16-3** and **16-4**.

18-3: Place a foot on the side leg bottom tube and lift the end of the frame up until the latches click once or twice, making sure both latches are fully engaged and in the same height slot. The end of the latch levers will be about 1.5 inches away from the leg when engaged properly and much closer if not fully engaged.

18-4: Repeat **Step 18-3** on the other end of the frame and then lower the two middle legs to the same slot, ensuring that the latches are fully engaged into the same slot on both side legs and the two middle legs. You may need a second person to lift the middle of the table to engage the latches fully on the middle legs.

18-5: Finally, double-check to make sure the frame is level. The slots on the legs are for rough height adjustment and the levelers on each leg are for fine height adjustment and leveling of the frame. See **Step 4-10**, if needed, for leveling review.

18-6: Your frame assembly is now complete.

Using the Pole Cradles

To use the Pole Cradles when loading the quilt and quilt batting

1. After loading the quilt backing and the quilt top, release the ratchets on the quilt-top pole.
2. Pull one side of the quilt-top pole out of the pole bracket and lay it in the corresponding pole cradle. Repeat on the other side of the quilt frame.
3. Lay the quilt batting on the quilt backing, align it with the top of the backing, and smooth it in place.
4. Unroll enough of the quilt top to reach the top of the quilt backing and batting.
5. Return both sides of the quilt-top pole to the pole brackets and put the ratchets back in place.
6. Proceed with stitching the plumb line, aligning the quilt top with the plumb line, basting the top edge and sides of the quilt top and attaching the clamps.

To use the Pole Cradles when advancing the quilt

1. When you're ready to advance your quilt, release the ratchets on the poles. Advance the quilt.
2. Pull one side of the quilt-top pole out of the pole bearing and lay it in the corresponding pole cradle. Repeat on the other side of the quilt frame.
3. Reach under the quilt top to smooth and straighten the batting.
4. Return both sides of the quilt-top pole to the pole brackets and put the ratchets back in place.
5. Proceed with smoothing and tensioning the quilt top, basting down the sides of the quilt and attaching the clamps.

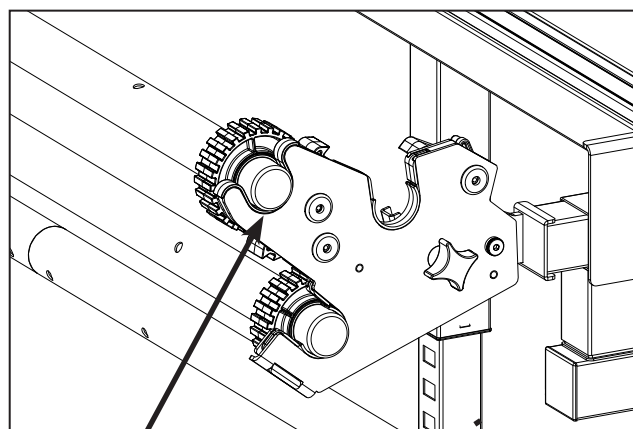

Pole Cradle Position

Troubleshooting

Track Support Joint Problems: Bumps or Unevenness

Issue:

At times the machine user feels what they describe as a bump or restriction that prevents them from quilting smoothly as they go over the frame table joints.

Background Information:

The track supports used on the frame are aluminum extrusions made with special dies. The aluminum is pushed and pulled through the dies during the extrusion process. This can cause slight variations between batches. Very long extruded pieces are later cut to make shorter pieces used in the frame system. Extrusions are cut to 4 foot, and 2 foot long pieces. Once the extrusion is cut, it is possible that it will be mated with another extrusion that is slightly different. The difference is typically less than the thickness of a sheet of paper.

The important surface of the track support is where the machine carriage wheels roll. A track support coupler makes the joint between two track supports stronger and aids in alignment of this important surface where the wheels make contact.

Even though the black plastic track insert covers the track support joint, it is still very important that the two track supports be as evenly aligned as possible at the joint. If the two surfaces do not match very closely, the end user will feel a bump or resistance at this point.

Important: It is very important that the frame table tops be even at the joints first, because they provide the foundation upon which the track supports mount.

Uneven Track Support Joints:

If you encounter an uneven track joint with the track support coupler tightened, first try turning one track support around to see if it matches better at the joint. If this does not make any difference, try other track supports to see if they match better at the joint.

Shimming Uneven Joints:

If after trying the above, you still have an issue with the joint not matching well enough, a kit is available to address this issue.

Track Alignment Kit: QF00100

“Track Alignment Kit” part number is QF00100. The kit consists of 8 pieces of foil tape with an adhesive and paper backing, and an instruction sheet. One kit is included with this frame.

Applying Foil Tape:

Foil tape can be used on the top of the track support coupler on the side that is lower. This will raise the lower track support to make it level with the other track support. A piece of the supplied foil tape is placed over the top of the track support coupler on the side that is low, as shown in the drawing on the next page. It is important to begin the tape placement at the center of the coupler.

Important: Ensure that the coupler with shim tape is installed onto the low side of the track extrusion first. If any portion of the tape protrudes onto the high side, it will make the high side even higher, defeating the purpose of the shim tape.

Usually only one thickness of foil tape will be needed to eliminate the issue. On the rare occasion where the mismatch is more extreme, two thicknesses of tape may be required to make both track supports even at the joint. For this reason eight pieces of foil tape are included in the kit, two for each joint, even though only one piece may be needed.

Track Support Joint Problems: Bumps or Unevenness - Continued

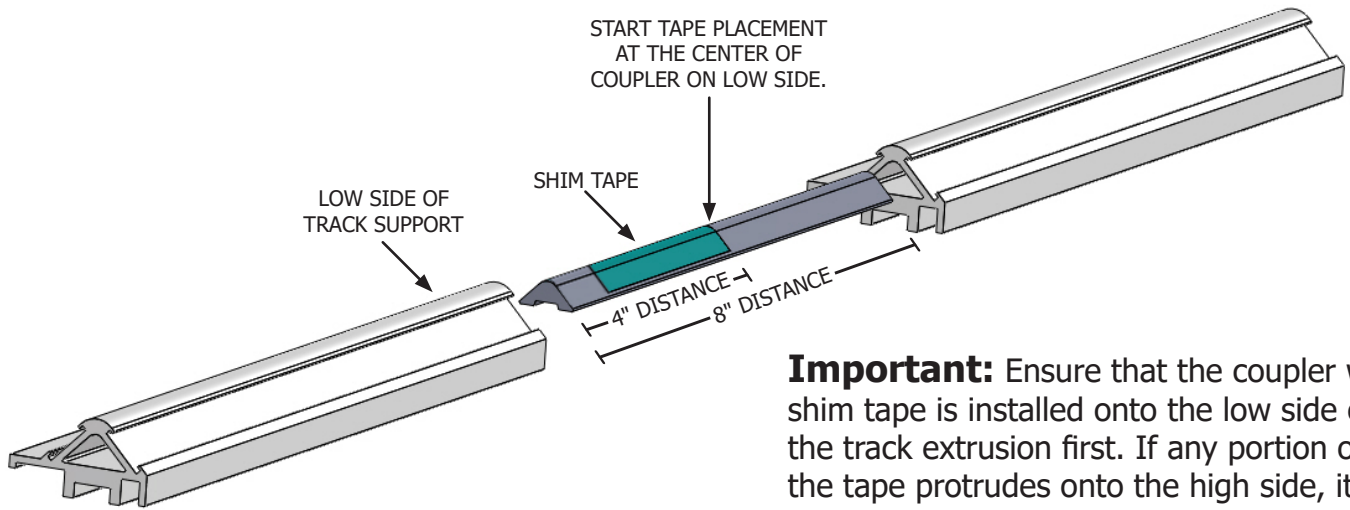

Important: Ensure that the coupler with shim tape is installed onto the low side of the track extrusion first. If any portion of the tape protrudes onto the high side, it will make the high side even higher, defeating the purpose of the shim tape.