



BERNINA Q-matic Software

User Manual



Table of Contents

IMPORTANT SAFETY INSTRUCTIONS	5	Reverse Sew	35
WARRANTY AND LIABILITY REGULATIONS for software	5	Connect	35
1 Important Information	7	Unconnect	36
1.1 Internet Usage with the Q-matic PC	7	Align	37
2 My Q-matic system	8	Resize	38
2.1 Introduction	8	5.4 Exchanging with Art & Stitch	40
2.2 Welcome to the World of BERNINA	8	5.5 Pantograph	40
3 My Q-matic Software	10	Creating pantographs	40
3.1 Installation	10	Realign Safe Area	41
3.2 Overview of Q-matic – Art & Stitch	10	6 Managing Designs	45
3.3 Overview of User Interface	11	6.1 Saving a quilt project	45
3.4 Overview Menu Bar	11	6.2 Opening a quilt project	45
3.5 Overview of Quilt Design Area	14	6.3 Creating a new quilt project	45
3.6 Overview of Tool Center	15	6.4 Deleting quilt projects	45
3.7 Software Operation	16	6.5 Saving quilt designs	46
4 Quilting Preparation	19	6.6 Importing quilt designs	46
4.1 Preparing the Machine	19	6.7 Deleting the Design	47
4.2 Starting Q-matic	19	6.8 Tagging Designs	48
4.3 Setting the Safe Area	20	7 Automatic Quilting	50
4.4 Entering the Quilt Size	20	7.1 Emergency	50
5 Creative Quilting	21	7.2 Sew Options	51
5.1 Selecting Designs for a Project	21	7.3 Sewing Quilt Designs	52
5.2 Placing Designs	22	7.4 Interrupting Sewing	52
MicroMove	22	7.5 Continuing Sewing after a Thread Break	53
Markers	23	7.6 Canceling Sewing	54
Boundary	23	8 Settings	55
Grab and Drop	27	8.1 Activating/Deactivating Securing Stitches	55
Multiply	27	8.2 Sewing On/Off	55
Deleting quilt designs	28	8.3 Activating/Deactivating Sounds	55
5.3 Modifying the Design	28	8.4 Easy Glide	55
Moving Quilt Designs	28	9 Maintenance	57
Copy	28	9.1 Reinstalling Windows	57
Rotate	28	9.2 Installing/Updating the Q-matic Software	57
Mirror and Flip	30	Reinstall or Update the Q-matic Software/Firmware	57
Mask	30	Downloading Software	57
Trim	32	Unpacking Software	58
		Installing Software	58

9.3	Installing/Updating Art & Stitch Software	61
9.4	Replacing the Q-matic PC	61
10	Errors and Faults	62
10.1	Troubleshooting	62
10.2	Error messages Q-matic software	62
10.3	Q-matic system status and troubleshooting	64
11	Appendix	65
11.1	Overview Quilt Designs	65
	Tips around the Quilt Designs	65
	Amanda Murphy	65
	Keryn Emmerson	68
	Patricia Ritter	70
	Aggy Burczyk	71
	Basic Shapes by AB	73
	Alfonsina Uriburu	75
	Linzi Upton	76
	Gerda Raschle	77
	Lisa Calle	78
	Tula Pink	78
	Sarah Vedeler	79
	OESD	80
	Index	85



IMPORTANT SAFETY INSTRUCTIONS

For the safe handling of the Q-matic System, observe the safety instructions in the following manuals:

- Frame Mounting Manual
- Assembly Instructions Q-matic
- User Manual BERNINA Q Series Machine

WARRANTY AND LIABILITY REGULATIONS for software

No part of this publication or the accompanying software may be copied or distributed, transmitted, transcribed, saved in a database, translated into a human or computer language or made accessible to third parties in any format or in any manner, whether electronically, mechanically, magnetically, manually or in any other way.

NOTE

The screen illustrations from the software in this guide are intended to be representations and may differ from those in the actual software delivered.

PRINTED USER GUIDE

Registered users of BERNINA Q-matic software are permitted to create one (1) copy of the BERNINA Q-matic instruction manual for personal use. This can be printed using a private printer or a commercial printing office.

LIMITED WARRANTY

BERNINA International AG warrants for a period of 90 days, commencing from the date of handover of the software to you, that the product is free from defects in materials and workmanship. You have the option, during the warranty period only, to return the products covered by this warranty, together with proof of purchase for the former, to BERNINA or an

authorized BERNINA specialist. You receive a replacement free of charge. You pay for any shipping and insurance costs. You alone bear the risk of any loss, damage or for losing products. The purchaser relies on their knowledge and judgment in selecting the software for their own use and assumes the entire risk as to the results and performance of the software. Subject to warranties and conditions determined by law, BERNINA International AG expressly refuses to recognize any other warranties and conditions, whether these are expressed or implied, including without limitation, warranties and conditions of merchantability, fitness for a particular purpose, property rights and infringement of third-party rights. BERNINA International AG does not guarantee that the software meets the purchaser's requirements, runs without any interruptions or errors or appears as shown in the accompanying documentation.

LIMITED LIABILITY

Where legally permissible, under no circumstances will BERNINA International AG or its developers, officers, employees or subsidiaries be liable to you for any consequential, incidental or indirect damages (including damages for loss of business profits, business interruption, loss of business information and the like), whether foreseeable or unforeseeable, arising out of the use of or inability to use the software or the control cabinet and cable supplied, as well as the instruction manual, regardless of the basis of the claim and even if BERNINA or an authorized BERNINA representative has been advised of the possibility of such damages. Some states or jurisdictions do not allow the exclusion of incidental, consequential or special damages, so the above limitations of liability may not apply to you.

TERMINATION

Your license to use the BERNINA Q-matic software is effective as long as you comply with the terms and conditions of the License Agreement. If you fail to comply with the terms and conditions of the License Agreement, this license shall automatically be



terminated immediately and without notice by BERNINA International AG. You may terminate this license at any time by returning the BERNINA Q-matic software and all copies thereof, the control cabinet and cables, as well as all accompanying documentation, to BERNINA International AG.

Use of antivirus software and other programs:

As a general rule, no programs other than the software already installed upon delivery should be installed on the supplied Q-matic PC. The Internet should only be accessed if this is expressly demanded by BERNINA or Art & Stitch customer service/support in connection with technical support. In addition, specifically, no antivirus software should be used other than the «Windows Defender» program already installed under Windows 10. Only if these measures are followed will the Q-matic system work without any problems. For this reason, always use your personal laptop or PC to surf the Internet in order to purchase designs or run other software.

License agreements for Q-matic software and Art & Stitch software

The license agreements for the Q-matic software and Art & Stitch software are automatically accepted by the owner/user when the software is installed and used.



2 My Q-matic system

2.1 Introduction

Large quilting projects can be created with the Q Series machines. The Q-matic automation system supports creative designing of the quilt layouts and automatic sewing out of designs on the quilt.

The Q-matic automation system comprises:

- Q-matic hardware:
Mechanical and electronic parts, for automated machine movements on the frame.
- Q-matic PC with touchscreen:
To operate the software.
- Q-matic software:
For designing whole quilt tops, editing individual designs and controlling the Q-matic hardware during automatic sewing out of the quilt design.

Further Information

The following information products are included with your BERNINA Q-matic:

- Assembly Instructions for the Q-matic System
- Instruction Manual for the Q-matic Software

The machine's instruction manual contains further important information regarding work with the Q-matic system.

The current version of the assembly instructions, the instruction manual, a video of the assembly instructions and a great deal of further information about the machine and the accessories can be found on our website <https://www.bernina.com>.

2.2 Welcome to the World of BERNINA

Made to create, this is the slogan of BERNINA. Not only with our machines do we support you in the implementation of your ideas. In addition to the offers listed below, we offer you lots of suggestions and instructions for your future projects as well as the opportunity to exchange ideas with other sewing, quilting and embroidery enthusiasts. We wish you lots of pleasure.

BERNINA YouTube Channel



On YouTube we offer a wide range of how-to videos and support concerning the most important functions of our machines. You can also find detailed explanations many presser feet, meaning that your projects will be a complete success.

<https://www.youtube.com/BerninaInternational>

Available in English and German.

inspiration – the Sewing Magazine in the Online Shop



Are you looking for ideas, sewing patterns and instructions for great sewing projects? In this case, the BERNINA magazine «inspiration» is exactly what you need. Three times a year, inspiration offers fantastic sewing and embroidery ideas. From seasonal fashion trends to trendy accessories and practical tips to original decorations for your home or cute sewing ideas for children.

The magazine is available in English, German, Dutch, and French.

In our online shop you can purchase "inspiration" as an e-magazine or as a print version, either as individual issues or as a subscription. Furthermore, there are many individual downloadable cutting patterns to discover! Please have a look at <https://www.bernina.com/inspiration>

BERNINA Blog



Refined instructions, free cutting patterns and embroidery designs as well as many new ideas: All this you can find in the weekly blog of BERNINA. Our experts give useful tips and explain step by step how you can achieve the desired result. In the community you can upload your own projects and exchange experiences and ideas with other sewing and embroidering enthusiasts.

<https://www.bernina.com/blog>

Available in English, German, Dutch and French.

BERNINA Social Media



Follow us on social networks to learn more about events, thrilling projects as well as tips and tricks about sewing, quilting and embroidering. We will keep you informed and we are looking forward to presenting highlights from the world of BERNINA.

<https://www.bernina.com/social-media>



3 My Q-matic Software

3.1 Installation

The Q-matic software and Art & Stitch software are installed during start up of the system. If the Q-matic software is not installed when the Q-matic PC is first started, it can be installed according to the section on «Installing software» (see page 58). More information on starting up can be found in the assembly instructions.

For more significant adaptations of designs, we recommend additionally installing «Art & Stitch» on a separate PC. The second Art & Stitch license that was supplied can be used for this.

3.2 Overview of Q-matic – Art & Stitch

The system consists of various mechanical components, electronics, the Q-matic PC, and the Q-matic and Art & Stitch software programs.

Q-matic Software

A quilting project can be easily and intuitively designed with the Q-matic software. The Q-matic software contains more than 325 designs, which can be edited through simple commands and placed on the quilt top. The finished quilting project can be automatically sewn.

Art & Stitch Software

Art & Stitch is a comprehensive digitization program with which you can create your own designs. Art & Stitch has more than 350 designs that can be freely used or edited. Use Art & Stitch to open files and designs of different longarm file formats and vector graphics, digitize a design from a picture, design an appliqué design or create creative filler designs as a background. In addition, existing designs can be altered at your discretion, saved in any major longarm file format and directly imported into the Q-matic software.

Further information and instruction manuals can be found at <https://artandstitch.com> or directly in the program under the «Help» function.

Exchanging Designs between Q-matic and Art & Stitch

Designs can easily be exchanged between Q-matic and Art & Stitch. A design can be transferred to Art & Stitch, edited there in detail, and also easily transferred back to Q-matic. The design must be saved in .ans format before transfer. Then it can be reimported at any time.

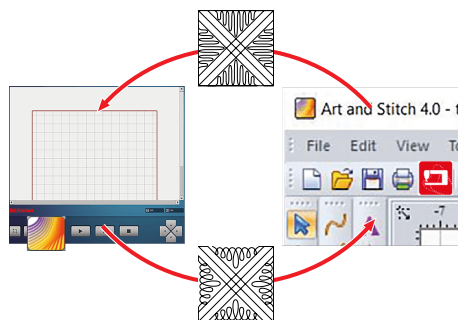



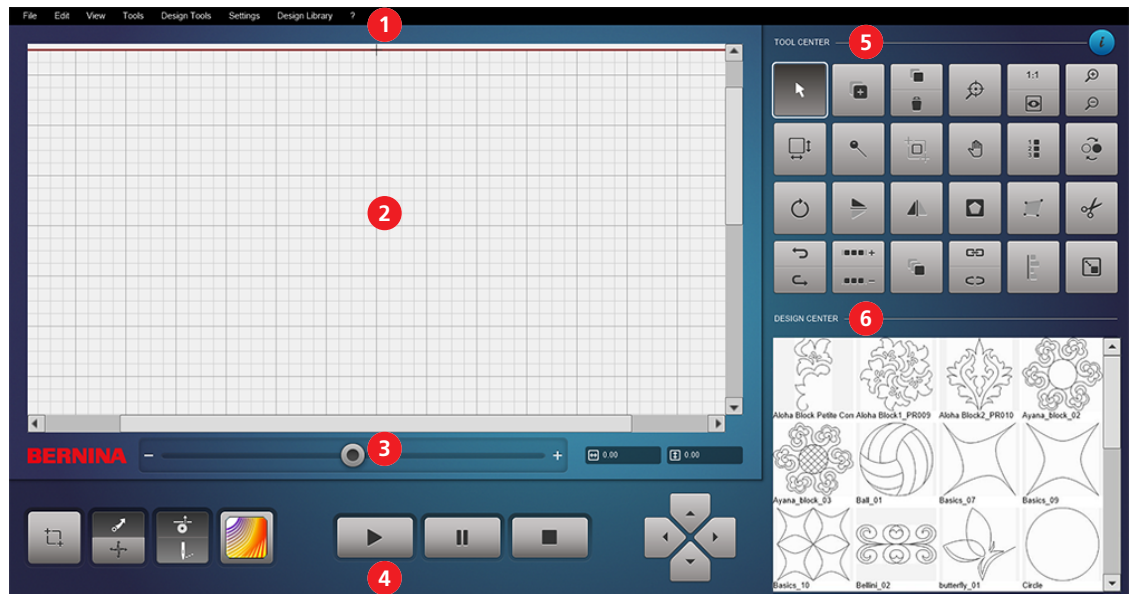

3.3 Overview of User Interface















- | | | | |
|---|-------------------|---|---------------|
| 1 | Menu Bar | 4 | Control Area |
| 2 | Quilt Design Area | 5 | Tool Center |
| 3 | Speed Control | 6 | Design Center |













3.4 Overview Menu Bar

The menu bar contains menus with the functions. Some functions are also available in the «Tool Center». The corresponding icons can be found in the overview table.

Menu	Function	Icon	Purpose
«File»	«Open Project»		Open a project.
	«New Project»		Create a new project.
	«Save»		Saving <ul style="list-style-type: none"> • «Save Design File» • «Save Project»
	«Delete»		Deleting <ul style="list-style-type: none"> • «Delete Design File» • «Delete Project»
«Edit»	«Delete a design»		Delete a design.
	«Copy a design»		Copy a design.
	«Undo»		Undo an action.
	«Redo»		Redo an action.

Menu	Function	Icon	Purpose
«View»	«Normal View»		Standard display. The center of the view can be established with zoom functions or the scroll bar.
	«Needle Center»		The needle position always remains in the center of the view.
	«Center Zoom»		Enlarge and center a section.
	«Actual Size»	1:1	Show the actual size of a section.
	«Full View»		Show the entire quilt.
	«Zoom In»		Enlarge a section.
	«Zoom Out»		Reduce a section.
«Tools»	«Safe Area»		Determine quitable area.
	«Select»		Select a design.
	«Quilt Size»		Specify quilt size.
	«Design Pool»		Select designs for «Design Center».
	«Markers»		Set markers.
	«Realign Safe Area»		Adjust the quitable area.
	«Grab/Drop»		Link the design with the needle and place with the machine.
	«Reverse Sew»		Change sewing direction.
	«Sew Options»		Change sewing settings.



Menu	Function	Icon	Purpose
«Design Tools»	«Resize»		Alter the quilt design size.
	«Flip»		Mirror design horizontally.
	«Mirror»		Mirror design vertically.
	«Rotate»		Rotate design.
	«Trim»		Trim the quilt design.
	«Mask»		Mask a design.
	«Boundary»		Set boundary lines.
	«Align»		Align designs.
	«Connect»		Connect designs.
	«Unconnect»		Unconnect designs.
	«E2E More»		Add pantograph design.
	«E2E Less»		Remove pantograph design.
	«Multiply»		Multiply designs.
«Settings»	«Pause to pull bobbin»		Interrupt sewing to pull the bobbin thread.
	«Sewing»		Activate/deactivate sewing.
	«Show jump stitches»		Show/hide jump stitches.
	«Sound»		Switch sounds on/off.
	«Easy Glide»		Activate/deactivate «Easy Glide»function.
	«MicroMove»		Activate/deactivate «MicroMove»function.
	«Easy Glide Settings»		Set resistance for Easy Glide.

Menu	Function	Icon	Purpose
«Design Library»	«Import Design»		Import design.
	«Manage Tags»		Manage tags.
	«Design Tags»		Assign/remove tags.
«?»	«How-To Videos»		Show how-to videos.
	«Contact Us»		Show contact details.
	«About»		Show software versions.

3.5 Overview of Quilt Design Area

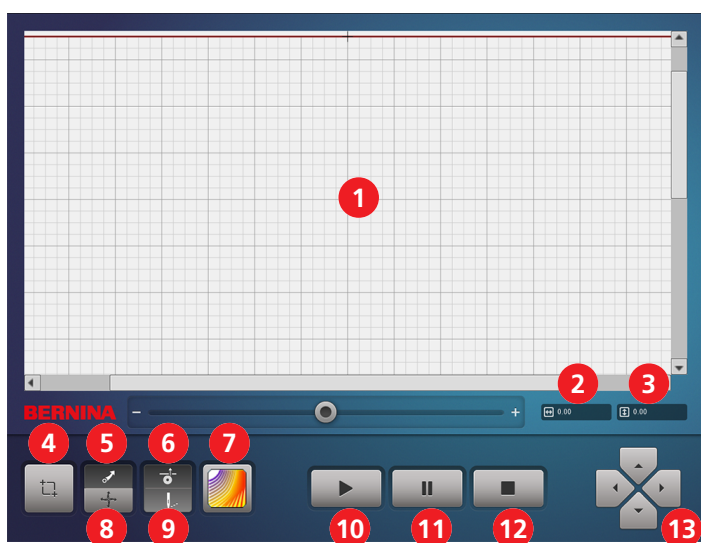

















- | | | | |
|---|--------------------------------|----|-------------|
| 1 | Quilt Design Area | 8 | «MicroMove» |
| 2 | «Width:» Width of the Design | 9 | «Sewing» |
| 3 | «Height:» Height of the Design | 10 | «Start» |
| 4 | «Safe Area», quiltable space | 11 | «Pause» |
| 5 | «Easy Glide» | 12 | «Stop» |
| 6 | «Pause to pull bobbin» | 13 | «Nudge» |
| 7 | «Art & Stitch» | | |

3.6 Overview of Tool Center



Illustration	Name	Purpose
	«Select»	Select a design.
	«Design Pool»	Select designs for «Design Center».
	«Copy»	Copy a design.
	«Delete»	Delete a design.
	«Center Zoom»	Enlarge and center a section.
1:1	«Actual Size»	Show the actual size of a section.
	«Full View»	Show the entire quilt.
	«Zoom In»	Enlarge a section.
	«Zoom Out»	Reduce a section.
	«Quilt Size»	Enter quilt size.
	«Markers»	Set markers.
	«Realign Safe Area»	Adjust the quiltable area.
	«Grab/Drop»	Link the design with the needle and place with the machine.

Illustration	Name	Purpose
	«Sew Options»	Change sewing settings.
	«Reverse Sew»	Change sewing direction.
	«Rotate»	Rotate design.
	«Flip»	Mirror design horizontally.
	«Mirror»	Mirror design vertically.
	«Mask»	Mask a design.
	«Boundary»	Set boundary lines.
	«Trim»	Trim the quilt design.
	«Undo»	Undo an action.
	«Redo»	Redo an action.
	«E2E+»	Add pantograph design.
	«E2E-»	Remove pantograph design.
	«Multiply»	Multiply designs.
	«Connect»	Connect designs.
	«Unconnect»	Unconnect designs.
	«Align»	Align designs.
	«Resize»	Alter the quilt design size.

3.7 Software Operation



The Q-matic PC can be operated with your finger or with a touchscreen pen.

Activate and Deactivate Functions



- > Tap the object to be edited in the «Quilt Design Area».
- > Tap the desired function in the «Tool Center» or in the menu.
- > Where applicable, implement settings and apply the function.





Confirming the Entry

Illustration	Name	Purpose
 	«Confirm»	Confirm the input and close the window.

Discarding the Entry

Illustration	Name	Purpose
 	«Cancel»	Discard input and close window.





Preview

Illustration	Name	Purpose
	«Preview»	Display settings in the preview.
	«Clear»	Discard changes and close preview.

Closing the Window

Illustration	Name	Purpose
	«Close»	Close the window. Unsaved changes are not applied.

Screen Gestures

Illustration	Name	Purpose
	Tap	Tap object.
	Long Tap	Press and hold object.
	«Zoom Out»	Reduce a section.
	«Zoom In»	Enlarge a section.
	Pan	Move the visible area of the «Quilt Design Area».

4.3 Setting the Safe Area

The «Safe Area» defines the quitable area, i.e. the area of the quilting project where the machine can sew. The settings window for the «Safe Area» opens automatically each time the software is started. If necessary, the «Safe Area» can be reset any time.



> Tap «Safe Area».



- > Move the sewhead to the top left corner of the quitable area.
- > To confirm the top left corner, tap «Set» (1) or press any toggle switch.
- > Move the sewhead to the bottom right corner of the quitable area.
- > To confirm the bottom right corner, tap «Set» (2) or press any toggle switch.
 - The positions are applied and the window is closed.
 - In the «Quilt Design Area», the «Safe Area» is marked with a red frame.

4.4 Entering the Quilt Size

The quilt size is displayed in the «Quilt Design Area» as a bold red frame. This allows the designs or pantograph designs to be adjusted to the quilt size.



> Tap «Quilt Size».

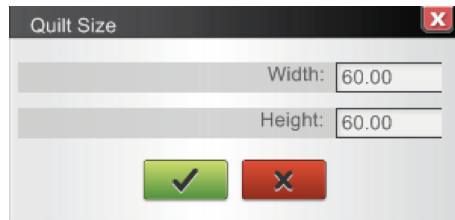

- ✓ > Enter and confirm the «Width» and «Height» in inches.
 - A bold red frame appears in the «Quilt Design Area», which corresponds precisely to the size of the quilt top.



5 Creative Quilting

5.1 Selecting Designs for a Project

All imported designs can be found in the «Design Pool» of the Q-matic software. For a better overview, it is recommended that you collect a preselection of the designs for the quilting project in the «Design Center». Tags can be used to search. The designs can be put into the «Quilt Design Area» from the «Design Center», and sewn out on the quilt from there.



- > Click «Design Pool».
- > To copy a design from the «Design Pool» (2) into the «Design Center» (3), double-click the design.
 - The design is copied into the «Design Center» (3).
 - The design is highlighted in the «Design Pool» (2) in light gray.



- > When all desired designs for the project have been selected, click «Close».

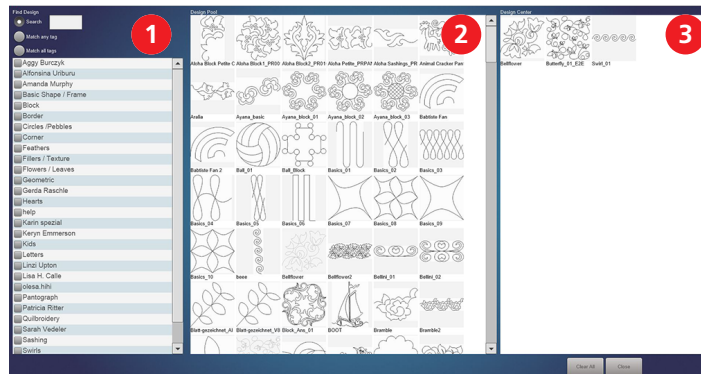

1 Search Area

3 «Design Center»

2 «Design Pool»

Operating Component	Purpose
Search Area (1)	
«Search»	Input field for search term.
«Match any tag»	Show designs that include one of the selected tags.
«Match all tags»	Show designs that include all selected tags.
List of Tags	List of all selectable tags.
«Design Pool» (2)	
«Design Center» (3)	Display of the selected designs.
«Clear All»	Remove all designs from the «Design Center».
«Close»	Close «Design Pool».

5.2 Placing Designs

Use the following functions to accurately place quilt designs on the quilt:

- Set markers («MARKERS»)
- Place design with sewhead («GRAB/DROP»)
- Set boundary («BOUNDARY»)
- Mask design («MASK»)
- Trim design («TRIM»)
- Align design («ALIGN»)
- Alter design size («RESIZE»)

For most of these functions, a design can be placed in the «Quilt Design Area» of the software or with the sewhead («Sewhead»). When placing the design with the sewhead, the design is connected to the needle. The sewhead is moved by hand to the desired start point. With the «MicroMove» function, the sewhead can be moved in small steps until the needle is precisely in the desired position. With the touch of a button, the needle position is transferred to the software.

MicroMove

With «MicroMove», lines and points in the «Quilt Design Area» can be set exactly by moving the needle over the quilt in microsteps. The position of the needle is transferred to the «Quilt Design Area» at the touch of a button.

MicroMove can be used with the following functions:

- Set markers («MARKERS»)
- Place design with sewhead («GRAB/DROP»)
- Set boundary («BOUNDARY»)
- Mask design («MASK»)
- Trim design («TRIM»)
- Align design («ALIGN»)
- Alter design size («RESIZE»)
- Realign the safe area («REALIGN SAFE AREA»)

Prerequisite:

- A design is selected in the «Quilt Design Area».
- > Tap a function in the «Tool Center».
- The settings window for the function opens in the software.
 - With some functions, the «Set» window opens on the display of the machine at the same time.
 - For some functions, «Sewhead» must be selected in the settings window in the «CONTROL» area.

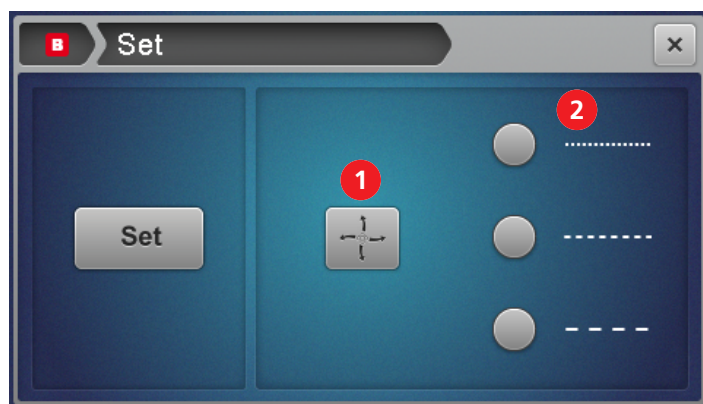

- > Move the sewhead close to the desired position.
- > Tap «MicroMove» (1).
- > Select the size of the microsteps (2).

- > To move the sewhead in microsteps, press the toggle switches on the handles.
 - Right handle, toggle switch I: Move the sewhead to the right
 - Right handle, toggle switch II: Move the sewhead to the left
 - Left handle, toggle switch I: Move the sewhead backward
 - Left handle, toggle switch II: Move the sewhead forward.
- > To move the sewhead in increments, briefly press the corresponding toggle switch.
- > To keep moving the sewhead, press and hold the corresponding toggle switch.
- > To set the point or the line, tap «Set».



- > When all points and lines are set, deactivate «MicroMove» (1).

NOTICE! As long as MicroMove is activated, the machine cannot be moved by hand.

Markers

Designs can be positioned precisely using markers. Several markers can be connected to one object. Such an object can be moved, edited, sewn out or deleted like any other design.



- > Click «Markers».

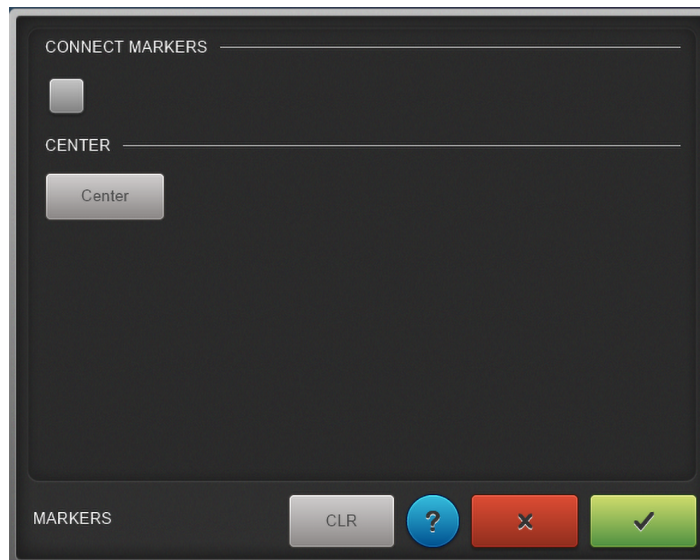

- The «Set» window opens on the display of the machine.
- > To set a marker, place the sewhead over the desired place, using «MicroMove» where applicable. (see page 22)
- > Tap «Set» on the screen of the machine or press any toggle switch.
 - The marker is transferred to the «Quilt Design Area».
- > Set further markers in the same way.
- > To connect the markers with each other, activate «Connect Markers» and click on all markers in turn on the Q-matic screen.
 - The markers are connected with a line to form an object.
- > To display the center of all markers, click «Center».
- > If necessary, delete all markers and lines.
- > Once markers are set as desired, click «Confirm».



Boundary

Designs can be placed precisely within boundary lines with the «Boundary» function. Boundary lines can be created with the sewhead or using the software. The design can be positioned within the boundary lines with unaltered proportions or distorted.



- > Click «Select» and select a design in the «Quilt Design Area».



> Click «Boundary».

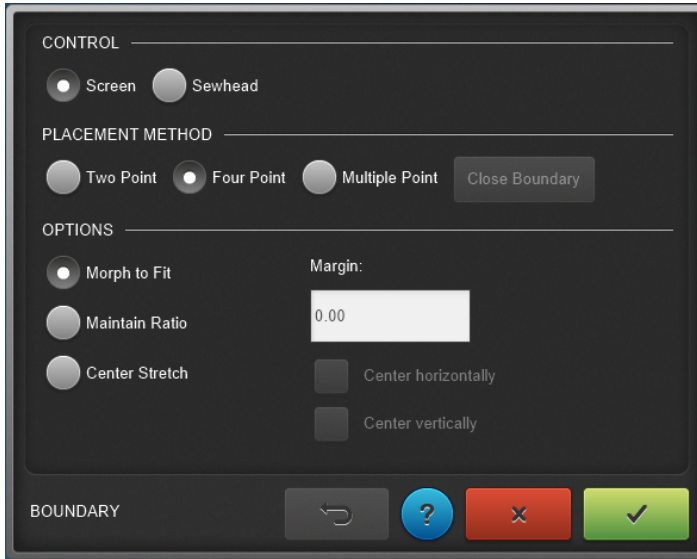

- > In the CONTROL area, select whether the boundary lines are set with the sewhead or using the software.
- > In the PLACEMENT METHOD area, select the type of boundary lines.
- > In the OPTIONS area, select the settings.
 - The selected settings are displayed in the preview.
- > If necessary, undo the settings.
- > Once the design is displayed as desired, tap «Confirm».



CONTROL

Operating Component	Purpose	Preview
«Screen»	Carry out the function on the Q-matic screen. > Set the points on the Q-matic screen.	
«Sewhead»	Carry out the function with the sewhead. > For each point, guide the needle to the desired position and tap «Set» to transfer the point.	

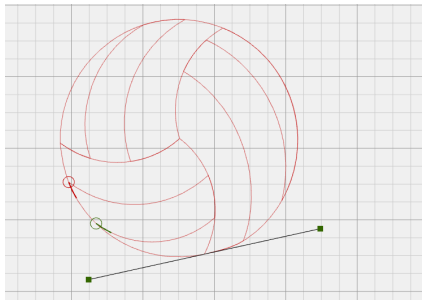
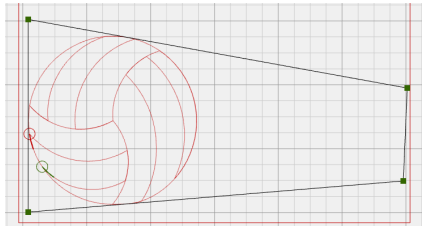
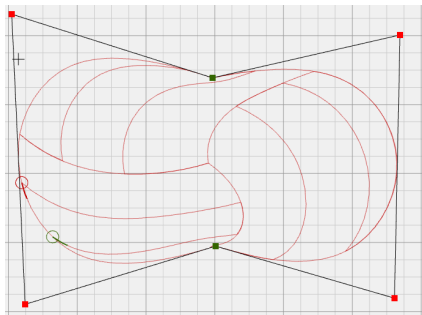

PLACEMENT METHOD

Operating Component	Purpose	Preview
«Two Point»	Position the design on a line drawn between two points. > Set two points, starting by setting the left point and then setting the right point.	
«Four Point»	Position the design within a four-point boundary. > Set four points, starting at the bottom left and setting points in counterclockwise order.	
«Multiple Point»	Position the design within a multiple-point boundary. > Set the desired number of points and close by pressing «Close Boundary». > Select four points as a positioning guide, starting at the bottom left and selecting points in counterclockwise order.	

«Morph to Fit», «Maintain Ratio» and «Center Stretch» OPTIONS

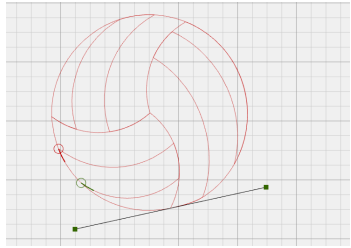
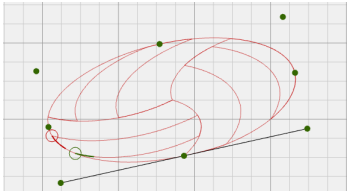
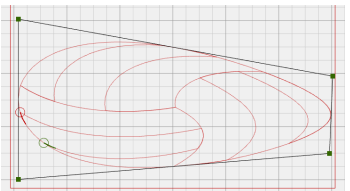
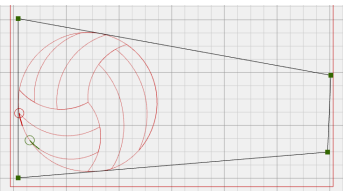
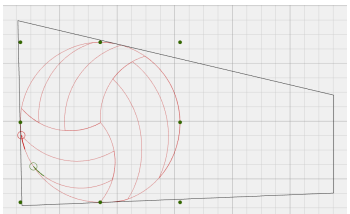
Option	«Morph to Fit»	«Maintain Ratio»	«Center Stretch»
Placement Method			
«Two Point»	Not possible		
«Four Point»			

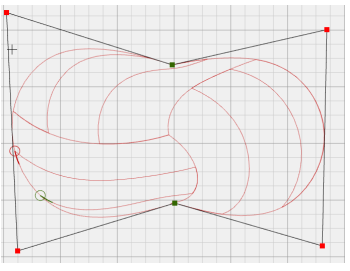

Option	«Morph to Fit»	«Maintain Ratio»	«Center Stretch»
Placement Method			
«Multiple Point»		Not possible	Not possible

«Center Horizontally» and «Center Vertically» OPTIONS

«Center Horizontally» and «Center Vertically» can be combined using the «Four Point» positioning method and the «Maintain Ratio» and «Center Stretch» options. The size of the design is based on the available distance to the nearest edge of the boundary frame.

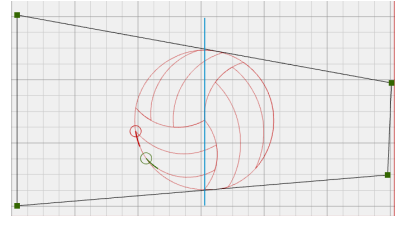
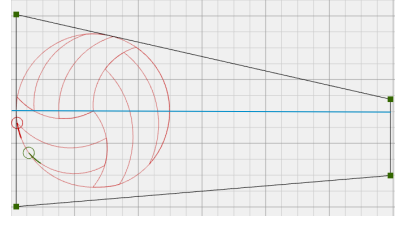
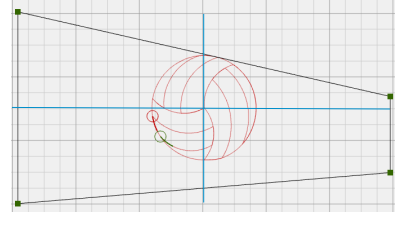
Option	Purpose	Preview
«Center Horizontally»	Align the design along the center line of the longer horizontal edge.	
«Center Vertically»	Align the quilt pattern along the center of the longer vertical edge.	
«Center Horizontally» and «Center Vertically»	Combination of «Center Horizontally» and «Center Vertically»	

«Margin» OPTIONS

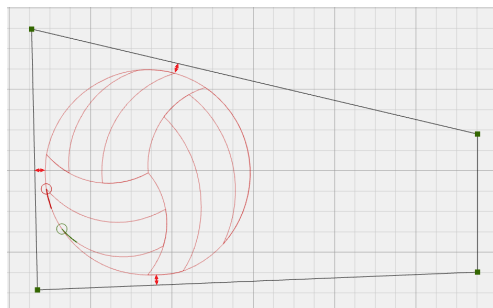

«Margin» can be used to set the distance between the design and the boundary frame.



Grab and Drop



«Grab/Drop» is always active if a design from the «Design Center» is placed in the «Quilt Design Area».

«Grab/Drop» can also be activated in order to move a design. When doing so, the design is linked with the needle and can be placed on the quilt with the sewhead in the desired place.

-  > Click «Select» and select a design in the «Quilt Design Area».
-  > Click «Grab/Drop».
 - The starting point of the active design is linked with the needle.
- > Move the sewhead so that the needle is over the desired place, using «MicroMove» where applicable. (see page 22)
 - In the «Quilt Design Area» the design is pulled along.
-  > Click «Grab/Drop» again or press a toggle switch on one of the handles.
 - The starting point of the design is placed at the needle position.

Multiply

Designs and rows of designs can be multiplied horizontally and vertically with the «Multiply» function. Simultaneously, the designs can be mirrored. The designs are **not** connected. The spaces between the designs can be enlarged or reduced.

-  > Click «Select» and select a design in the «quilt design area».
-  > Click «Multiply».



- > Multiply the designs horizontally in the ACROSS area. To do so, enter the number of designs in the input field and add these with «+» or remove them with «-». If necessary, mirror the inserted designs in the «Flip» area.
- > Multiply and mirror the designs vertically in the DOWN area.
- > In the SPACING (INCHES) area, set the distances and the offset between designs.
-  > Once the designs are displayed as desired, click «Confirm».

ACROSS and DOWN



Operating Component	Purpose
«Flip»	Mirror designs.
«Hor»	Mirror horizontally.

Operating Component	Purpose
«Vert»	Mirror vertically.
«All»	Mirror all designs.
«Alt»	Mirror every second design.

SPACING (INCHES)



Entry Field	Purpose
«Horizontal»	Enter increment for horizontal distance.
«Vertical»	Enter increment for vertical distance.
«Offset»	Enter increment for offset between rows of designs.

Deleting quilt designs



-  > Click «Select» and select a design in the «Quilt Design Area».
-  > Click «Delete».
 - The design is removed from the «Quilt Design Area».

5.3 Modifying the Design

Moving Quilt Designs

-  > Click «Select» and select a design in the «Quilt Design Area».
- > Move the design.
-  > Click «Select».

Copy

-  > Click «Select» and select a design in the «quilt design area».
-  > Click «Copy».
 - The copied design is inserted with the starting point at the current needle position of the machine. If several copies are inserted and the machine is not moved, all copies are inserted on top of each other.
-  > Click «Select».

Rotate

The design can be rotated freely or in individual increments. Each point of the grid can be selected as a rotation point.

-  > Click «Select» and select a design in the «Quilt Design Area».



> Click «Rotate».

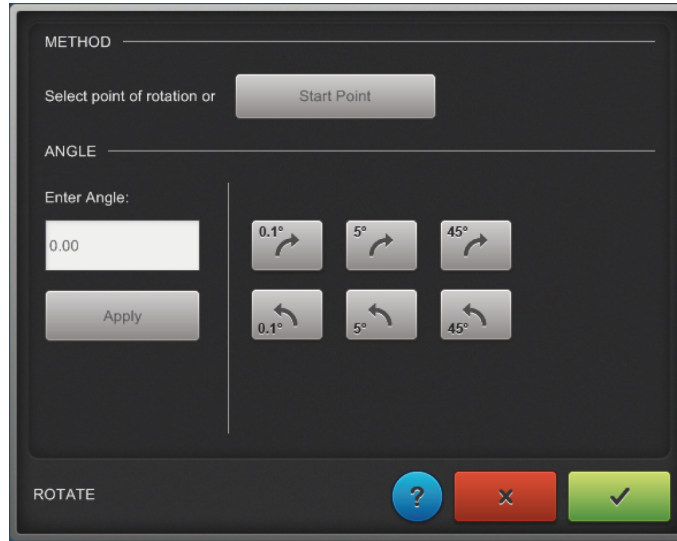

– The design is surrounded by a grid. The red dot marks the rotation point.

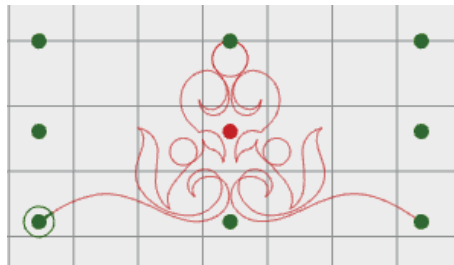

- > Select the rotation point in the METHOD area.
- > Set the angle of rotation in the ANGLE area.
 - The rotation is shown in the preview.









> Once the design is displayed as desired, click «Confirm».

METHOD



Option	Purpose	Preview
«Select rotation point»	Press and hold the desired rotation point until it turns red.	
«Start Point»	Set the start point of the design as a point of rotation.	

Angle

Option	Purpose
«Enter Angle»	Enter angle of rotation.
«Apply»	Confirm entry.
	Rotate design 0.1° clockwise.
	Rotate design 5° clockwise.
	Rotate design 45° clockwise.
	Rotate design 0.1° counterclockwise.
	Rotate design 5° counterclockwise.
	Rotate design 45° counterclockwise.

Mirror and Flip

Designs can be mirrored on a horizontal or vertical axis.

-  > Click «Select» and select a design in the «Quilt Design Area».
-  > To mirror the design on a vertical axis, click «Mirror».
-  > To mirror the design on a horizontal axis, click «Flip».

Mask

Masking is a partial concealment of a quilt design, as under a mask. A shape or another design can be used as a mask.

Creating a Mask from a Design

- > In the «Quilt Design Area», position a design as a background design.
- > Position a second design as a mask over the top of the background design, as desired.



- > Click «Select», then click the background design.

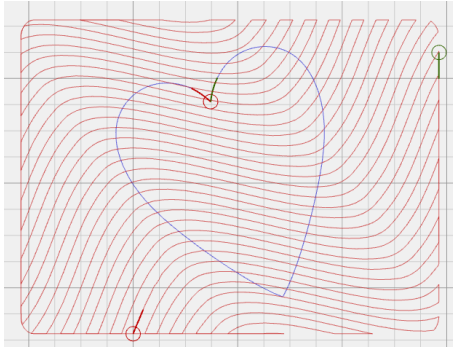

- > Click «Mask».

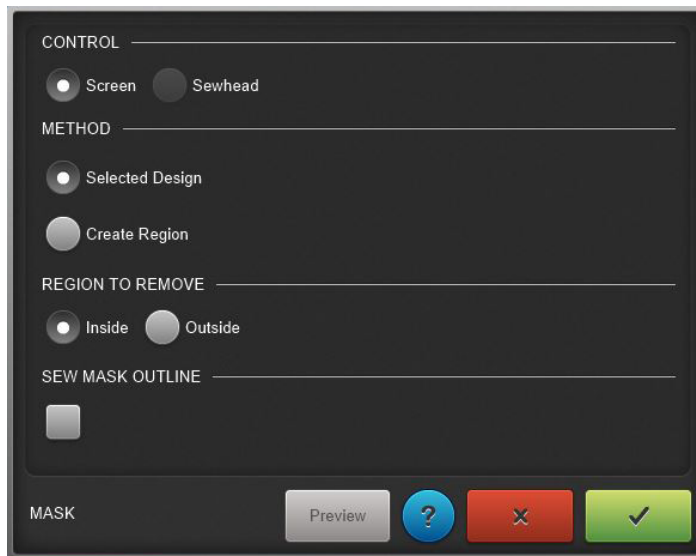

- > Click «Screen» in the CONTROL area.
- > Click «Selected Design» in the METHOD area.
- > In the REGION TO REMOVE and SEW MASK OUTLINE areas, select the desired options.
- > Click the mask in the «Quilt Design Area».
 - The mask is displayed in black.

- Preview > To display a preview, click «Preview».
 - The design is displayed masked with the selected options in the «Quilt Design Area».

- Confirm > Once the design is displayed as desired, click «Confirm».

Creating a Mask from a Shape

- > In the «Quilt Design Area», position a design as a background design and select it.

- > Click «Mask».
- > Click «Sewhead» or «Screen».
- > Click «Create Region».

- > Create a shape from multiple points using the sewhead or in the «Quilt Design Area».
 - The mask is displayed in the «Quilt Design Area» as a black shape.



- > Set the options as desired.
- > Display the preview.
 - The design is displayed masked with the selected options in the «Quilt Design Area».
- > Once the design is displayed as desired, click «Confirm».

Setting Options

REGION TO REMOVE	«Inside»	«Outside»
SEW MASK OUTLINE		
«Sew Mask Outline» activated		
«Sew Mask Outline» deactivated		



Trim

Designs can be trimmed along a horizontal, vertical or diagonal line.

-  > Click «Select» and select a design in the «Quilt Design Area».

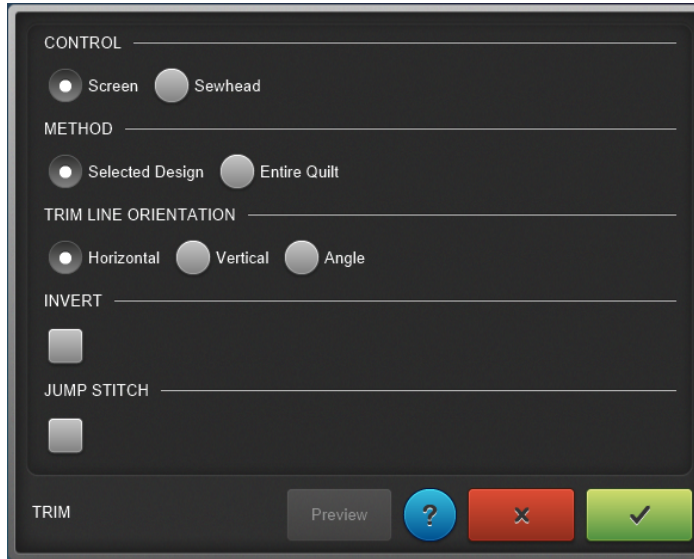
 > Click «Trim».



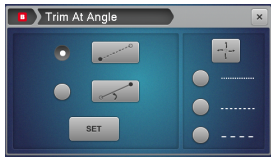
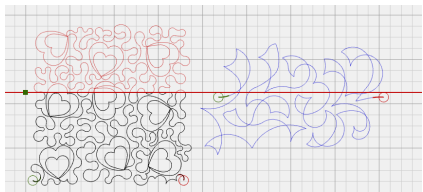

- > In the «CONTROL» area, select how the function is to be carried out.
- > In the «METHOD» area, select what is to be trimmed.
- > In the «TRIM LINE ORIENTATION» area, select the orientation of the trim line.
- > In the «INVERT» area, select which part is to be trimmed.
- > In the «JUMP STITCH» area, select whether or not jump stitches are to be sewn.
-  > To display a preview, click «Preview».
 - The design is displayed trimmed with the selected options in the «Quilt Design Area».
-  > Once the design is displayed as desired, click «Confirm».

Operating Component	Purpose	Preview
CONTROL		
«Screen»	Carry out the function on the Q-matic screen.	
«Sewhead»	Carry out the function with the sewhead.	
METHOD		
«Selected Design»	Trim the selected quilt pattern.	

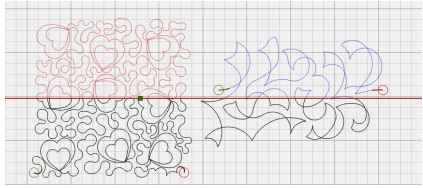
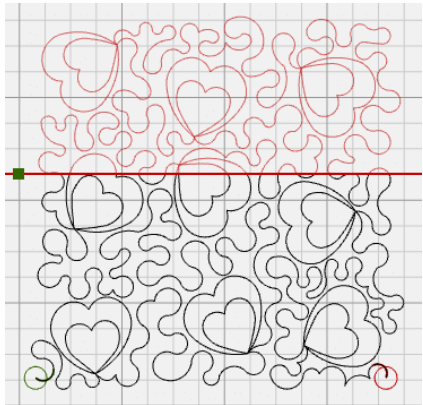
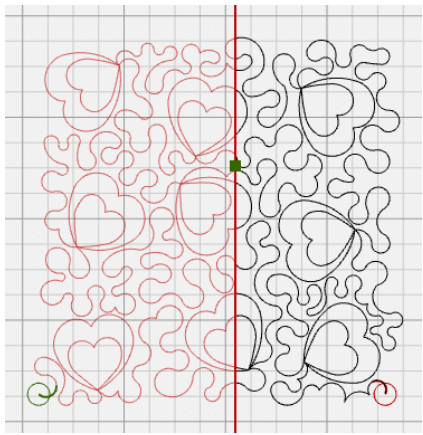
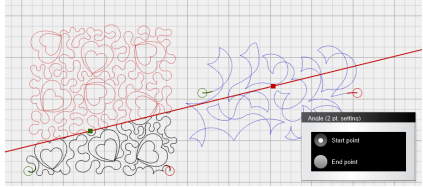

Operating Component	Purpose	Preview
«Entire Quilt»	Trim the entire quilt.	
TRIM LINE ORIENTATION		
«Horizontal»	Set a horizontal trim line.	
«Vertical»	Set a vertical trim line.	
«Angle»	Set a diagonal trim line. <div data-bbox="619 1541 943 1733" style="border: 1px solid gray; padding: 5px; margin: 10px 0;"> Angle (2 pt. setting) <div style="background-color: black; color: white; padding: 5px; display: flex; justify-content: space-around;"> Start point End point </div> </div> <ul style="list-style-type: none"> > Click «Start Point» and set a point to use as the start point of the trim line. > Click «End Point» and set a point to use as the end point of the trim line. <ul style="list-style-type: none"> – The diagonal trim line is transferred to the «Quilt Design Area» and displayed as a red line. 	



Operating Component	Purpose	Preview
«Invert»	Invert the cutting area. Parts of the design shown in black will be trimmed off.	
«Jump Stitch»	<p>Activate/deactivate Jump Stitch.</p> <p>If «Jump Stitch» is activated, the jump stitches will not be sewn out, and the stitches are displayed in gray.</p> <p>If «Jump Stitch» is not activated, the jump stitches will be sewn out, and the stitches are displayed in red.</p>	

Reverse Sew

Each design has a defined start and end point. The start point is green and the end point is red. These determine in which direction the design is sewn. The sewing direction can be changed with «Reverse Sew».

- > Click «Select» and select a design in the «Quilt Design Area».
- > Click «Reverse Sew».
 - The start and end point of the design are switched, the design is sewn in the opposite sewing direction.

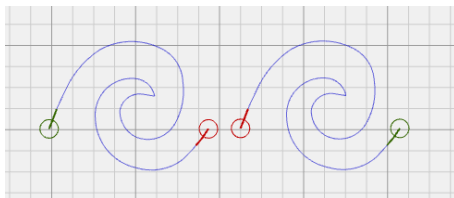

Connect

Q-matic offers three options for interconnecting designs:

- Group: The designs are put together into one group and can be edited as one design.
- Attach: The start point of a design is connected to the end point of the selected design.
- Link: The start point of a design is connected to the end point of the selected design with a joining seam.

- > Click «Select» and select a design in the «Quilt Design Area».

 > Click «Connect».

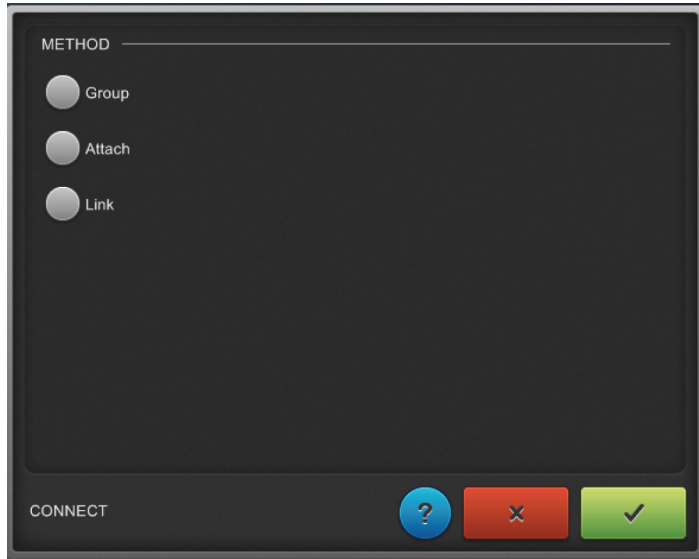

- > Select the type of connection in the METHOD area.
- > Click other designs in the «Quilt Design Area».
-  > Click «Confirm».
 - Designs are sewn out in the order in which they were clicked.

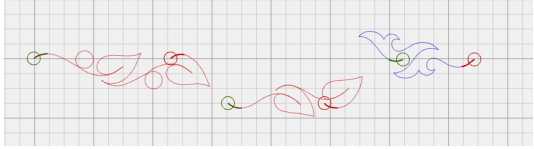
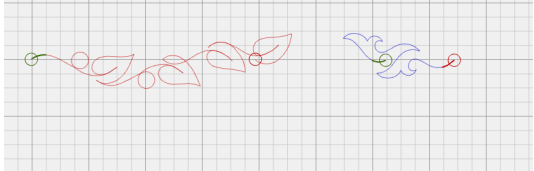
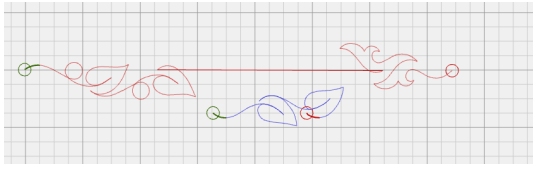
Operating Component	Purpose	Preview
«Group»	Group designs. The designs (red) are put together into one group and can be edited as one design. They remain in their position and are sewn out as a group.	
«Attach»	Attach designs. The start point of the second design is connected directly to the end point of the selected design. One design is created.	
«Link»	Link designs. The start point of the second design is connected to the end point of the first design with a joining seam. The connected designs remain in their position and are sewn out as a single design.	

Unconnect

Designs that were connected with the «Connect» function can be separated. Not all connections are separated at the same time, but rather in the order in which they were put together.

Even designs that have one jump stitch or several jump stitches can be separated.



- > Click «Select» and select a connected design in the «Quilt Design Area».
- > Tap «Unconnect».
 - The designs are separated.

Align

Several designs can be aligned with each other in different ways.

- > Click «Align».



- > In the «CONTROL» area, select how the function is to be carried out.
- > Select the alignment of the designs in the «ALIGNMENT ORIENTATION» area.
- > Place line.
- > Select design.
 - The aligned designs are shown in the «Quilt Design Area».
- > Once the design is displayed as desired, click «Confirm».

Operating Component	Purpose	Preview
CONTROL		
«Screen»	Carry out the function on the Q-matic screen.	
«Sewhead»	Carry out the function with the sewhead.	
ALIGNMENT ORIENTATION	Select alignment: Top, bottom, centered horizontally, left, right or centered vertically.	

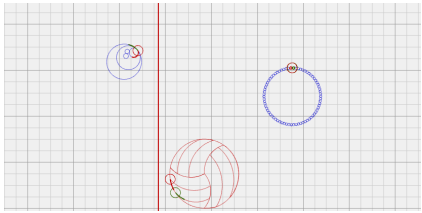
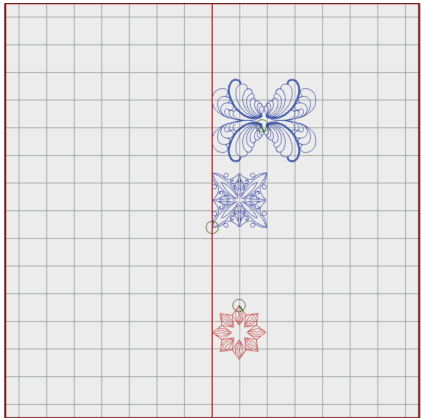
Operating Component	Purpose	Preview
«Place Line»	Set orientation line.	
«Select Design»	Select design.	

Resize

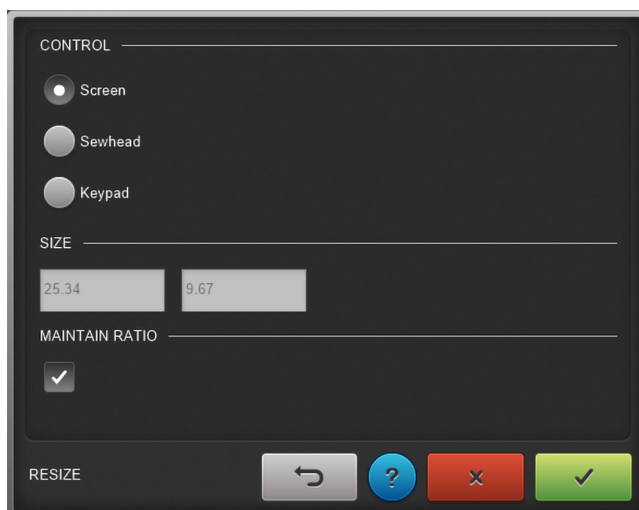

The design size can be altered proportionally or non-proportionally.

- > Click «Select» and select a design in the «Quilt Design Area».
- > Click «Resize».

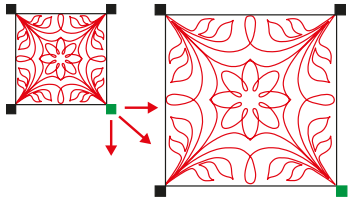

- > In the CONTROL area, select how the design size is to be altered.
- > In the SIZE area, enter the design width and/or the design height.
- > In the MAINTAIN RATIO area, select whether the size is to be altered proportionally or non-proportionally.
- > If necessary, undo settings.
- > Once the design is displayed as desired, click «Confirm».

CONTROL

Operating Component	Purpose	Preview
«Screen»	Carry out the function on the Q-matic screen. > Drag the green point away from the opposite point. > If necessary, set a green point by tapping another point and holding until it is displayed in green.	
«Sewhead»	Carry out the function with the sewhead. > Set the start point. > Drag the machine diagonally away from the start point. > Set the end point.	
«Keypad»	Enter details via the keyboard.	

SIZE

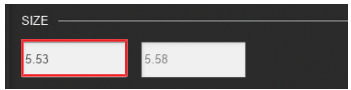
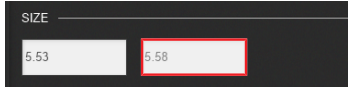
Operating Component	Purpose	Preview
Width	Input field for the design width. > Enter width with the keyboard.	
Height	Input field for the design height. > Enter height with the keyboard.	

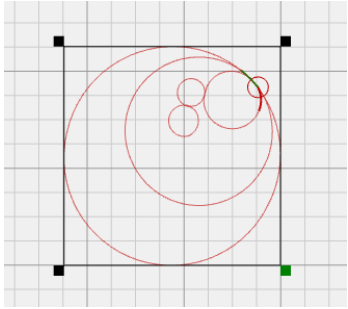
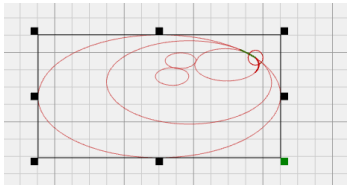

MAINTAIN RATIO

Operating Component	Purpose	Preview
«Maintain Ratio» activated.	Alter the design size proportionally.	
«Maintain Ratio» deactivated	Alter the design size non-proportionally.	

5.4 Exchanging with Art & Stitch

For further changes to designs, it is recommended to transfer the design to the Art & Stitch software, edit it there and transfer it back to Q-matic. It's better to perform extensive work on a separate PC with mouse operation.

Further information and instruction manuals for Art & Stitch can be found on the website <https://www.artandstitch.com>, and in the program under the Help function.

- > Click «Select» and select a design in the «quilt design area».
-  > To transfer the design to Art & Stitch, click the «Art & Stitch» icon.
 - Art & Stitch is opened and the design is transferred.
- > Edit the design in Art & Stitch.
- > Before the design is transferred to Q-matic, set the «Line Sew Type» to «Running stitch».
- > Save the design in the «Documents» folder or another folder with the file extension .ans.
-  > To transfer the altered design to Q-matic, click the «Q-matic» icon.
 - The design is shown in the «Quilt Design Area» of Q-matic.
- > Import the design into the «Design Pool». (see page 46)

5.5 Pantograph**Creating pantographs**

Designs suitable for pantographs can be combined using the functions «E2E+», «E2E-» and «Multiply». The rows of designs can be mirrored horizontally and vertically, and the distances between the rows of designs can be changed.

Creating a Row of Designs

Prerequisite:

- A pantograph design is placed in the «Quilt Design Area».
- > Click «Select» and select a design in the «Quilt Design Area».



- > To add a design to the row, click «E2E+».



- > To remove a design from the row, click «E2E-».

Multiplying Rows of Designs



- > Click «Multiply».

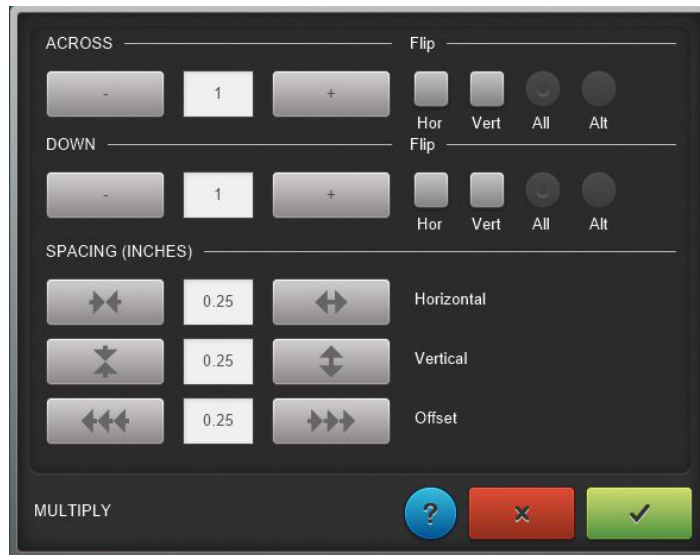

- > In the «DOWN» area, specify and mirror the desired number of rows of designs.
- > In the SPACING (INCHES) area, set the distances and the offset between designs.
- > Once the designs are displayed as desired, click «Confirm».



Realign Safe Area

This function is used primarily for pantograph quilting. The Safe Area can be repositioned to the actual needle position in the «Quilt Design Area» after advancing the quilt, in order to ensure that the next rows of the pantograph can be precisely sewn.

Prerequisite:

- A pantograph has been created in the «Quilt Design Area» and the first rows of the pantograph have been quilted.
- The selected Safe Area is large enough that at least one row of the pantograph can be positioned within it.

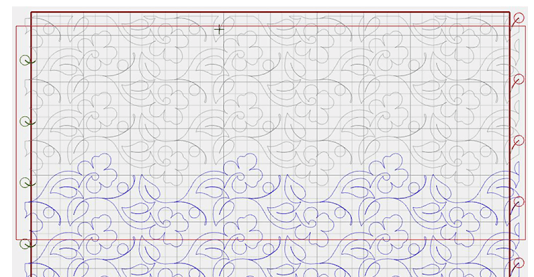

> Advance and baste the quilt.



> Look for a distinctive spot in the middle of the design and position the needle over that spot.

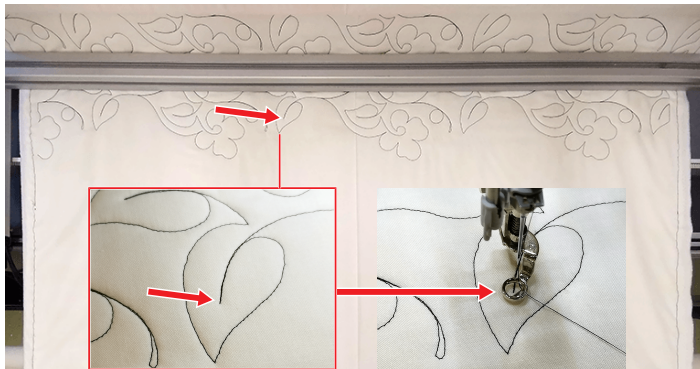

– In the «Quilt Design Area», the needle will still be at the old position (A) before the quilt was advanced. It must now virtually be moved to the actual needle position (B).

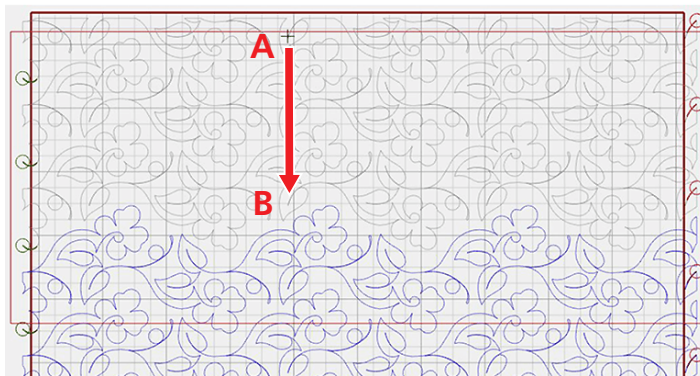

> Click «Realign Safe Area».

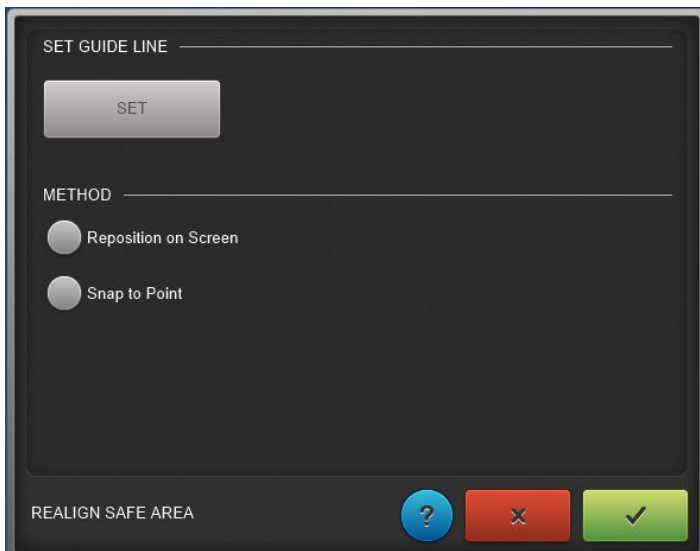

- > Click «Set» under «SET GUIDE LINE».
 - In the «Quilt Design Area», a vertical guide line will be shown at the actual needle position.

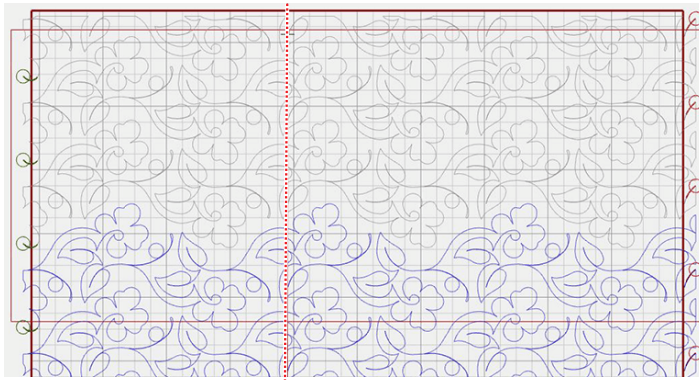

- > Move the Safe Area using either «Reposition on Screen» or «Snap to Point».

Repositioning the Safe Area using Reposition on Screen

- > Click «Reposition on Screen».
- > Move the needle cross in the «Quilt Design Area» near the actual needle position.
- > Zoom in on the area around the actual needle position and position the needle cross precisely at the actual needle position using the nudge buttons.

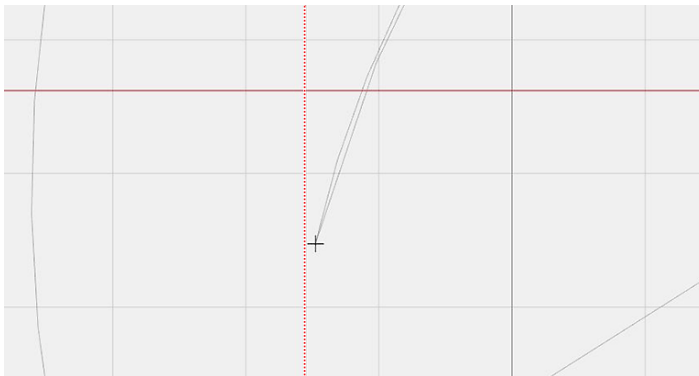

- ✓ > Click «Confirm».

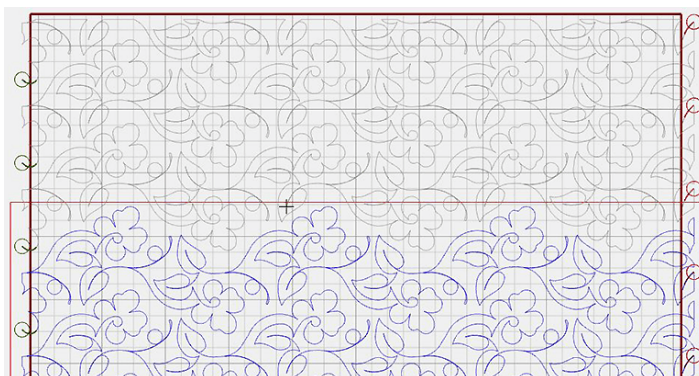

Repositioning the Safe Area using Snap to Point

- > Click «Snap to Point».
- > Zoom in on the area around the actual needle position.

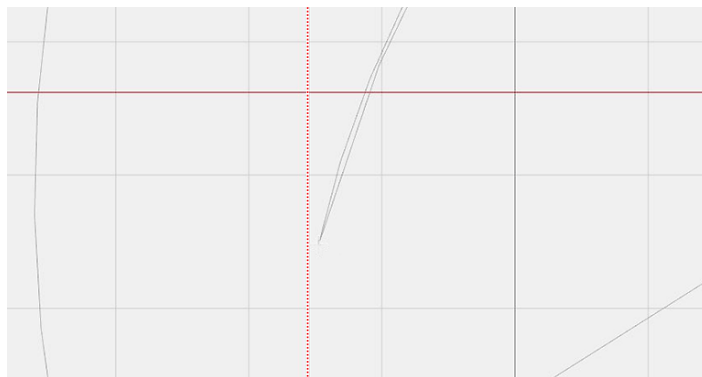

- > Click the actual needle position.

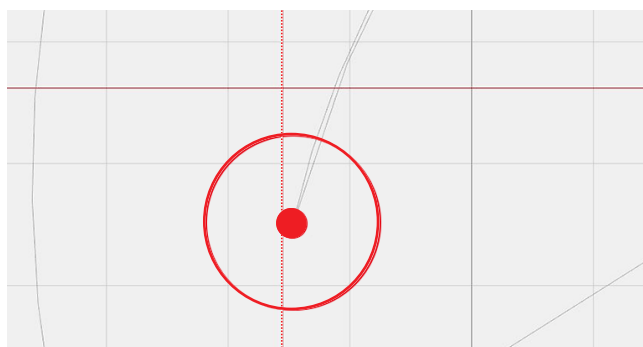

- ✓ > Click «Confirm».

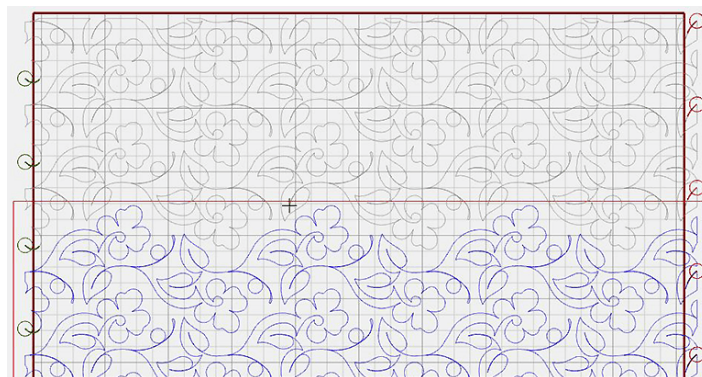

6 Managing Designs

6.1 Saving a quilt project

AutoSave

Quilting projects are automatically saved to the project folder at regular intervals in the «AutoSave» folder.

Saving Manually

Quilting projects can also be saved in any filing location.

- > In the menu bar, click «File» → «Save» → «Save project».
 - Explorer will now open.
- > Enter the file name of the quilting project.
- > Click «Save».
 - The quilting project is saved in .bqp format in the «Projects» folder.

6.2 Opening a quilt project

Saved quilting projects can be opened and changed. Before a project can be opened, the open project must be saved and closed.

- > In the menu bar, click «File» → «Open project».
 - A new window opens.
- > Open the desired storage medium in Explorer.
- > Select the desired project in .bqp format.
 - The selected quilting project is opened.

6.3 Creating a new quilt project

Prerequisite:

- If a quilting project is opened, it must first be saved.
- > In the menu bar, click «File» → «New project».
 - A new window opens.

6.4 Deleting quilt projects

Self-created quilting projects can be deleted.

- > In the menu bar, click «File» → «Delete» → «Delete project».

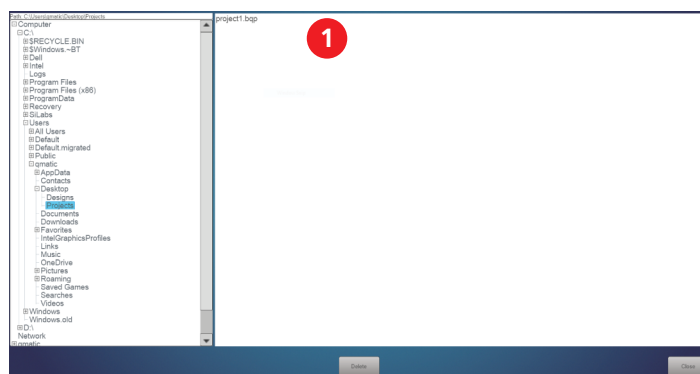

- > Activate the quilting project you want to delete in area (1).
 - The selected quilting project is highlighted in blue.

Delete

- > Click «Delete».

Close

- > To delete the quilting project, click «Yes».
- > To close the window, click «Close».

6.5 Saving quilt designs

Self-created or altered designs can be saved in Explorer or on a USB stick.

Saving a Design in Explorer

Prerequisite:

- A design is activated.
- > In the menu bar, click «File» → «Save» → «Save design file».
 - Explorer will now open.
- > Enter the file name of the design.
- > Click «Save».
 - The design is saved in .bqm format in the «Designs» folder.
 - The design can be imported into the «Design Pool». (see page 46)

Saving a Design on a USB Stick

Prerequisite:

- A design is activated.
- > Insert the BERNINA USB stick into a USB connection on the Q-matic PC.
- > In the menu bar, click «File» → «Save» → «Save Design File».
 - Explorer will now open.
- > Click the USB stick in Explorer.
- > Enter the file name of the design.
- > Click «Save».
 - The design is saved in .bqm format on the USB stick.
 - The design can be edited on another PC.

6.6 Importing quilt designs

Designs in .bqm and .dxf formats can be imported.

Importing a Design from Explorer

- > In the menu bar, click «Design Library» → «Import Design».

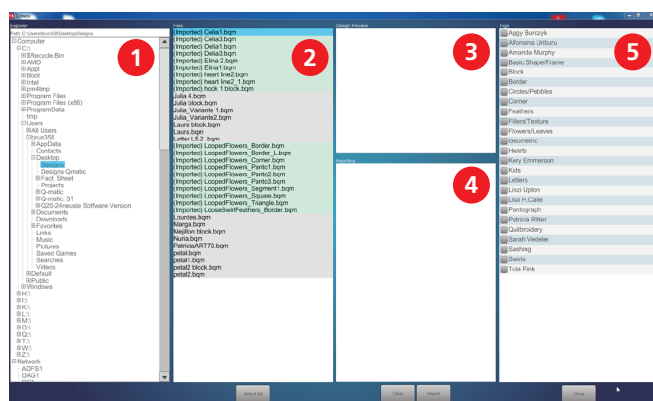

- > In «Explorer» (1), select the folder in which the designs are stored.
 - The designs are shown in the «Files» (2) area.
- > Click the desired design under «Files» (2).
 - The design is shown as a preview under «Design Preview» (3).
- > Double-click the desired design under «Files» (2).
 - The name of the design is shown under «Importing» (4).
- > Click «Select all» under «Files» (2).
 - All designs are shown under «Importing» (4).

- > Assign the desired tags (5) to the design.
- Import** > To import the design into the «Design Pool», click «Import».
 - The design name is shown in the «Files» display with the addition of «Imported».
- Close** > Close the window.
 - The designs are visible in the «Design Pool».

Importing a Design from a BERNINA USB Stick

- > Insert the BERNINA USB stick into a USB connection on the Q-matic PC.
- > In the menu bar, click «Design Library» —> «Import Design».
- > Open the BERNINA USB stick in Explorer.
- > Import design.

6.7 Deleting the Design

Designs can be deleted from the «Design Center» and from the «Design Pool».

Removing a design from the «Design Center»

For a better overview, it is recommended that you remove designs that are not needed for the project from the «Design Center».

- +** > Activate «Design Pool».

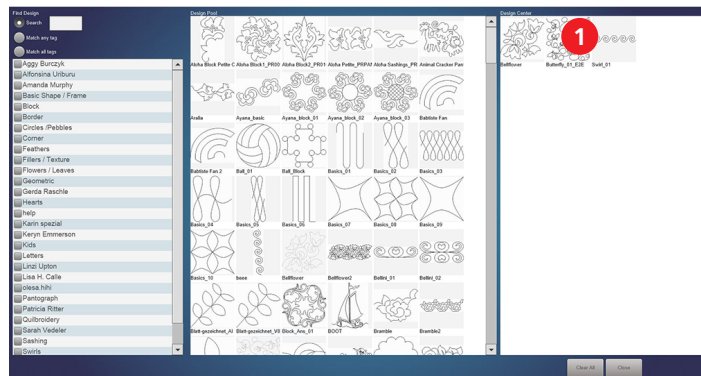

- > To remove just one design from the «Design Center» (1), double-click the design.
- Clear All** > To remove all designs from the «Design Center», click «Clear All».
- Close** > To close the window, click «Close».

Removing a design from the «Design Pool»

Remove individual designs from the «Design Pool».

- > In the menu bar, click «File» —> «Delete» —> «Design File».

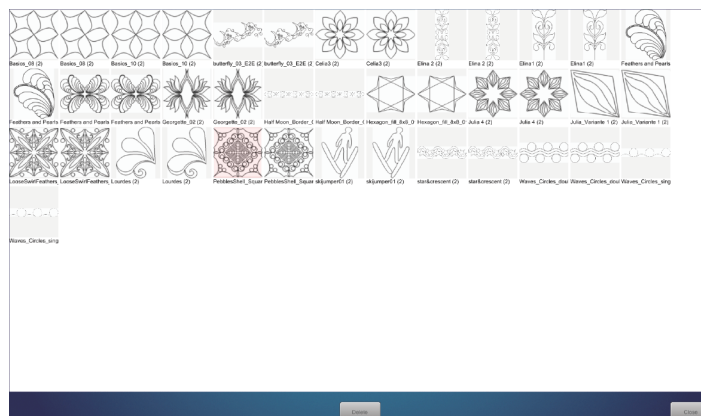

- > Click the design which is to be deleted.
 - The selected design is highlighted in color.

Delete

- > Click «Delete».

- > To remove the design, click «Yes».

Close

- > To close the window, click «Close».

6.8 Tagging Designs

Designs can be provided with tags. For example, tags can be created according to the designer, form and type. Tags make searching for suitable designs easier.

Managing Tags

Tags can always be altered or deleted.

- > In the menu bar, click «Design Library» —> «Manage Tags».



- > To add a tag, click «Add» (1).



- > Type in the tag and click on «Confirm».

- > To alter a tag, click the desired tag and click «Modify» (2).



- > Alter the tag and click on «Confirm».

- > To delete a tag, click the desired tag and click «Delete» (3).

Close

- > To close the window, click «Close».

Assigning/Removing Tags

A tag can be assigned to a design so that it is more easily found.

> In the menu bar, click «Design Library» —> «Design Tags».

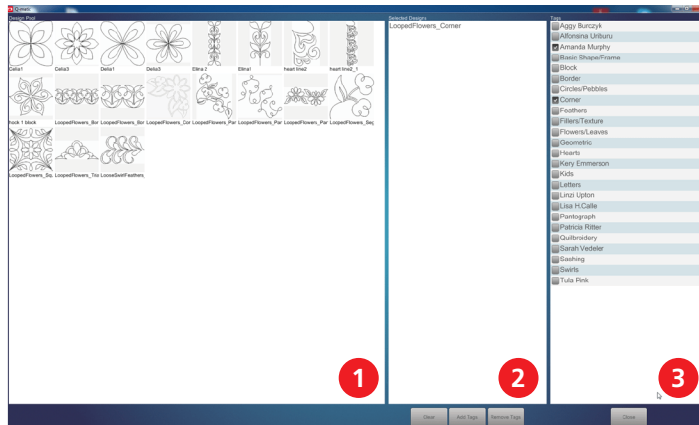

- > In the «Design Pool» (1), double-click on one or all designs that you want to give the same tag.
 - The selected designs are shown under «Selected Designs» (2) and highlighted in gray in the «Design Pool» (1).
- > To assign tags, activate the desired ones under Tags (3) and click «Add Tags».
- > To remove tags, activate the ones to be removed under Tags (3) and click «Remove Tags».
- > To accept the changes and close the window, click «Close».

Close

7 Automatic Quilting

7.1 Emergency



WARNING

System Not Controllable

Risk of injury.

- > Press the red emergency stop button.

Switching Off in an Emergency

Only press the emergency stop button in case of emergency!

- > Press the red emergency stop button at the top of the control cabinet.



- The power supply is immediately interrupted.

Switching On after an Emergency

- > Turn the red emergency stop button in the direction of the arrow.



- The emergency stop button is unlocked.
 - The power supply is reactivated.
- > Restart the system. (see page 19)

7.2 Sew Options

The sewing sequence of the designs and the features of the securing stitches can be set in the sew options.

Activating the Function

1 ■
2 ■
3 ■

- > Click «Sew Options».



Determining a Sewing Sequence

- > Click «Select» in the «SEWING SEQUENCE» area.
- > In the «Quilt Design Area», click the designs in the order in which they should be sewn.
 - The designs are numbered.

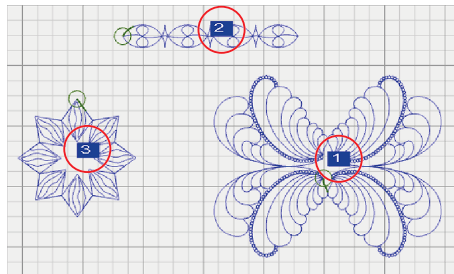

Editing a Queue

Designs can be removed from the queue or put in the queue at any time in the «QUEUE» area.

- > To remove a design from the queue, click «Dequeue» and click on the designs that you don't want to be sewn.
 - Designs are shown in gray.
- > To remove all designs from the queue, click «Dequeue All».
- > To put a design in the queue, click «Queue» and then click all designs that are to be sewn.
 - Designs are shown in blue.
- > To put all designs in the queue, click «Queue All».

Setting Securing Options

Settings for securing stitches can be applied in the «TIE ON/TIE OFF» area.

- > To sew securing stitches at the start of the seam, activate «Tie on».
- > If you don't want to sew securing stitches at the start of the seam, deactivate «Tie on».
- > To sew securing stitches at the end of the seam, activate «Tie off».
- > If you don't want to sew securing stitches at the end of the seam, deactivate «Tie off».
- > To set the length of the securing section, activate the desired length under «Length».

- > To set the length of securing stitches, set the desired value under «SPI».
- ✓ > Once all sewing settings are set as desired, click «Confirm».

7.3 Sewing Quilt Designs

All designs in the queue that are within the «Safe Area» can be sewn.

Prerequisite:

- A design in the queue is within the «Safe Area».
- «Sewing» is activated.

- > If desired, activate «Pause to pull bobbin».
- ▶ > To start sewing, click «Start».

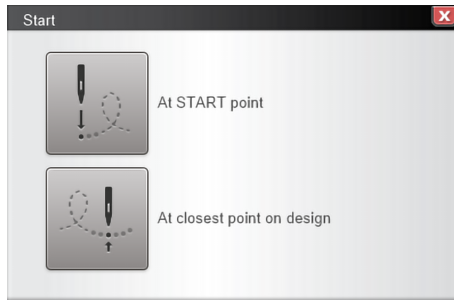

- ▶ > Click «At START point».
 - The window is closed and the machine moves to the start point of the design.

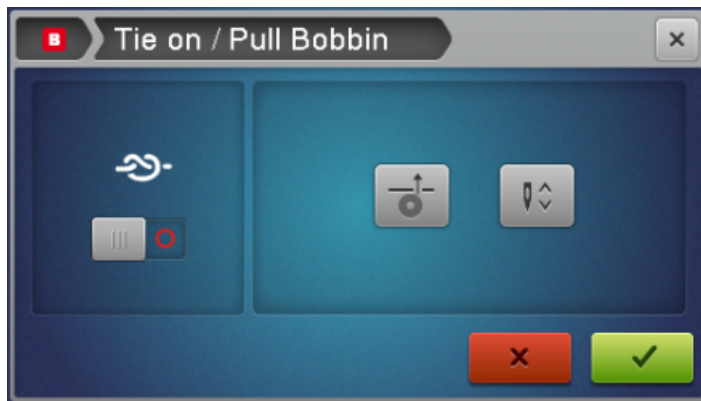

- ▶ > Pull bobbin thread in one step or
- ▶ > pull bobbin thread in two steps.
- ▶ > If necessary, activate or deactivate securing stitches.
- ✓ > Click «Confirm».
 - The machine starts sewing the design.

7.4 Interrupting Sewing

Sewing can be interrupted, e.g. to adjust the thread tension or the SPI (stitches per inch).

Prerequisite:

- The machine is sewing.

-  > To interrupt sewing, click «Pause» on the machine or on the Q-matic PC.

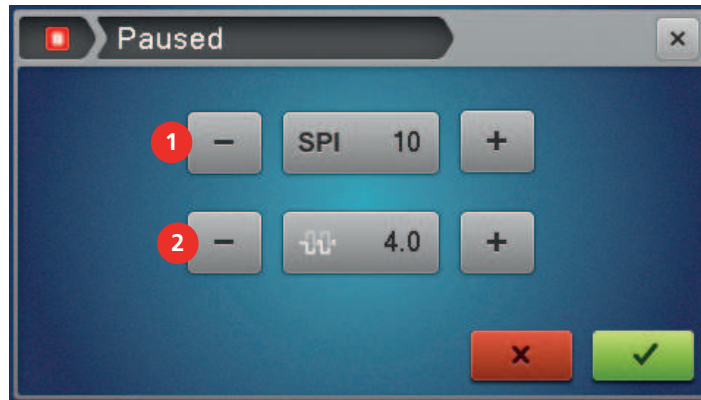



- > Adjust the «SPI» (1) on the screen of the machine.
 > Adjust the thread tension (2) on the screen of the machine.
 > To confirm the changes and continue sewing, click «Confirm».

7.5 Continuing Sewing after a Thread Break

If the upper thread breaks or the bobbin thread indicator detects the end of the bobbin thread (only if the bobbin thread indicator is switched on), the machine stops automatically after a few stitches. The needle can be repositioned and sewing can be continued with the quilt sequence control function.

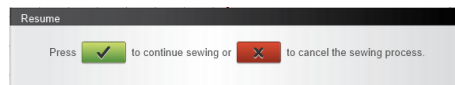
- > After a thread break, change the bobbin or rethread the upper thread.
 > Click to dismiss all error messages on the machine and in the software.
 > To continue sewing, click «Start».



-  > To confirm the query on the screen, click «Confirm».

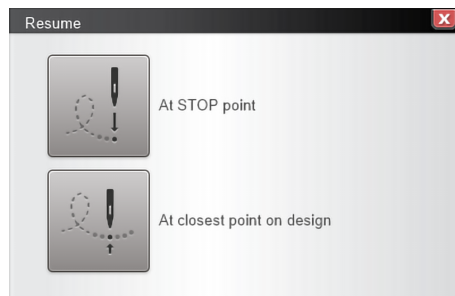

- > Position the needle near the point where the thread broke.
 > Click «At closest point on design».
 – The window is closed and the machine moves the needle precisely onto the design.

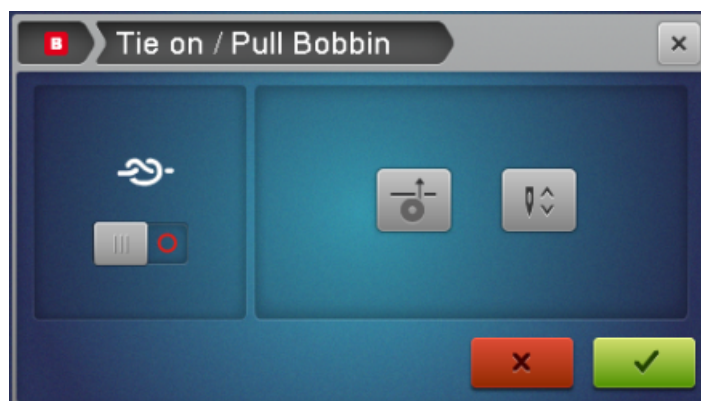



> Pull up the bobbin thread.



> Click «Confirm».

– The window is closed and the machine continues sewing.

7.6 Canceling Sewing

Prerequisite:

- The machine is sewing.



> To cancel sewing, click «Stop».



> Click «Start».

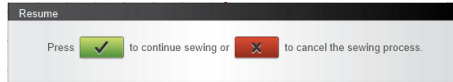

> Click «Cancel».



8 Settings

8.1 Activating/Deactivating Securing Stitches

Securing can generally be activated or deactivated in the «Tools» --> «Sew Options» menu, or in the Tool Center under «Sew Options». In addition, securing can be deactivated or aktivität on a case by case basis upon starting sewing.

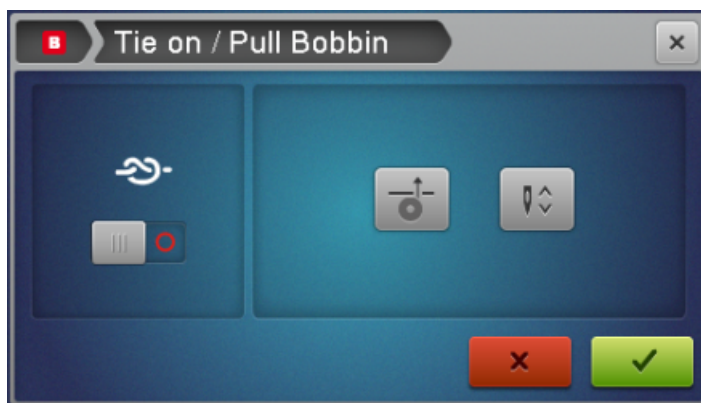

- > To activate or deactivate securing in individual cases, switch «Securing Stitches» on or off on the machine in the «Tie on/Pull Bobbin» window.

8.2 Sewing On/Off

With «Sewing», you can set whether the machine should sew the design, or just trace without sewing.

This function is available in the settings menu («Settings» --> «Sewing») and in the «Control Area».



- > To sew a design, activate «Sewing».
- > To just trace a design, deactivate «Sewing».

8.3 Activating/Deactivating Sounds

In the settings menu, you can set whether an akustic signal should sound time the screen is operated. The signal can be selected in the Windows settings.

- > To activate sounds each time the screen is operated, activate «Settings» —> «Sound» in the menu.
- > To deactivate sounds each time the screen is operated, deactivate «Settings» —> «Sound» in the menu.

8.4 Easy Glide

«Easy Glide» makes moving the machine manually on the frame easier.

After starting the software, «Easy Glide» is always activated.



Activating/Deactivating Easy Glide

- > To activate or to deactivate Easy Glide, click «Easy Glide».

Setting the Support

The support when manually moving the machine can be set separately for the X direction and Y direction.

It should be possible to manually move the machine by applying a comfortable amount of force. If the machine can only be moved with difficulty, increase the support. If the machine continues moving on its own after being pushed, decrease the support.

To prevent the machine colliding with the frame or the Q-matic PC, the support should be set so that the machine comes to a stop on its own.

Unpacking Software

On a Windows Computer

Prerequisite:

- The USB stick is formatted to FAT32 and inserted into the PC.
- > Right-click on the ZIP file «BERNINA_Q-matic_PC-Setup xx.xx.xx.zip» and select «Extract all ...» from the context menu.

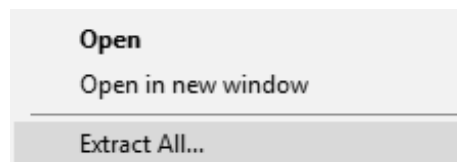

- > If a security warning is displayed, allow the unpacking to continue and do not cancel since, otherwise, the folder will not be unpacked.
- > Click on the «Browse...» button and select the USB stick as the target folder. When doing so, ensure that the unpacked files are saved directly onto the top level of the USB stick.
- > Check the box for «Show extracted files when complete» and click on the «Extract» button.

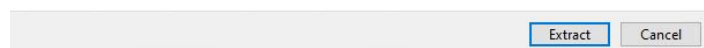
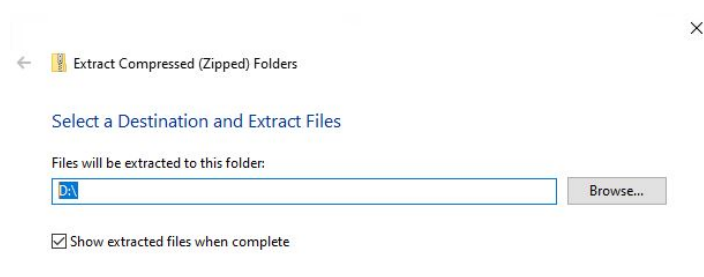

- As soon as the file has been extracted, the USB stick opens with the Q-matic installer file.
- > Eject and remove the USB stick.

On a Mac Computer

Prerequisite:

- The USB stick is formatted to FAT32 and inserted into the PC.
- > Unpack the «BERNINA_Q-matic_PC-Setup xx.xx.xx.zip» ZIP file with a double click.
 - The contents of the ZIP file will be copied to a folder.
- > Drag files from the folder to the USB stick.
- > Eject and remove the USB stick.

Please note: For newer software versions, the ZIP file stored in the downloads folder may have been already unpacked.

Installing Software

Prerequisite:

- The control cabinet is switched on and connected with the Q-matic PC. The LED on the control cabinet is illuminated in green.
- The Q-matic installation file can be found on the BERNINA USB stick.

- > Insert a BERNINA USB stick with the new software version into a USB connection of the Q-matic PC.
- > Open the USB stick folder.

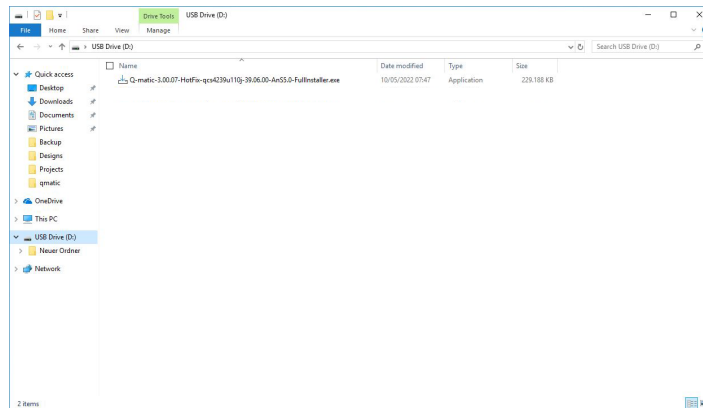

- > Double-click on the «Q-matic-xxx-Fullinstaller.exe» file.
 - The installer starts.
- > Confirm that the installer is allowed to make changes by answering the query with «Yes».
- > Confirm all queries with «Next» and start installation with «Install».
- > Confirm the query Installation Silicon Laboratories with «Next».



- > Agree to the license agreement with Silicon Laboratories and confirm with «Next».

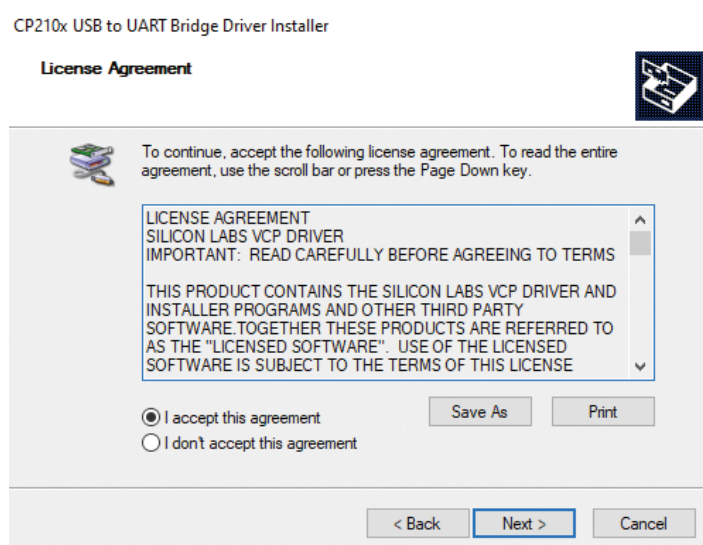

- > Confirm the installation of Silicon Laboratories with «Finish».

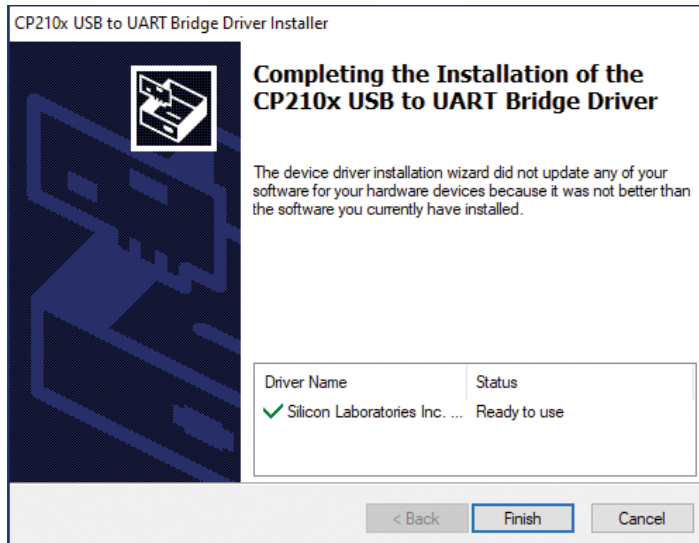

- > Wait until the installation is complete.

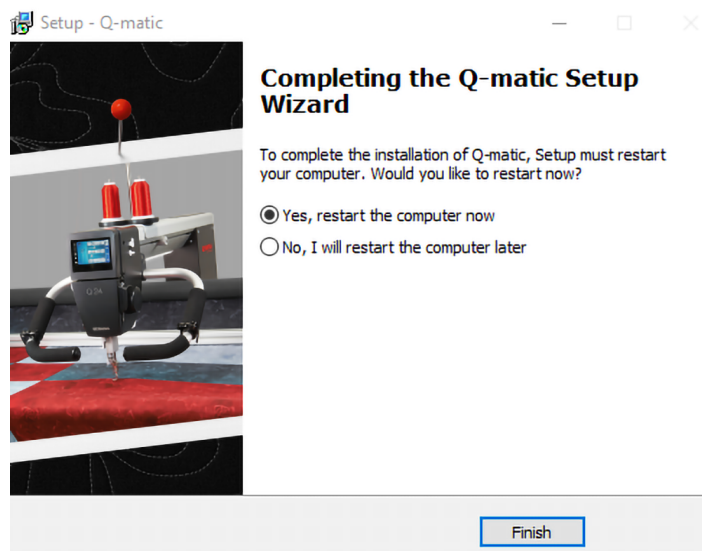

- > To finish the setup wizard, select «Yes, restart the computer now» and tap «Finish».

Updating Control Cabinet Firmware

- > Start Q-matic software.
 - If the firmware of the control cabinet is not up to date, you are requested to update it.



- > Confirm the request to install the control cabinet firmware with «Yes» and wait until the installation is finished.

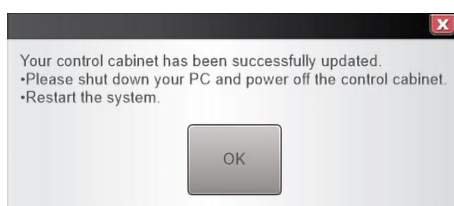

- > Confirm that installation is finished with «OK».
- > Eject and remove the USB stick.

- > Close the Q-matic software and shut down the Q-matic PC.
- > Switch off the control cabinet using the power switch.
- > Switch on the control cabinet and Q-matic PC.
- > Check the version of the software and the control system.

Updating the Machine Firmware

During the installation of the Q-matic software, a «Q Series Firmware» folder is created on the desktop. The folder contains the subfolders «Q16-PLUS» and «Q20-24» with the firmware files for the respective machine type.

- > Open the «Q Series Firmware» folder.
- > Copy files from the subfolder of your machine type onto the BERNINA USB stick and eject the USB stick.
- > Insert the USB stick into the USB port of the Q Series machine.
- > Tap «Home».



- > Tap «Setup Program».



- > Tap «Machine settings».



- > Tap «Maintenance/update».



- > Tap «Updating firmware».



Update

- > To start the firmware update, tap «Starting firmware update».

NOTICE

Incomplete update due to removing the BERNINA USB stick too early

If the software has not been updated or has not been fully updated, the machine cannot be used.

- > Remove the BERNINA USB stick only once the update has been successfully completed.

9.3 Installing/Updating Art & Stitch Software

When installing the Q-matic software, Art & Stitch is also updated at the same time if an older version was present on the computer.

Saving your personal data before an installation or update is recommended.

More information and software updates can be found at: <http://artandstitch.com>

If problems arise with the update, ask Art & Stitch.

9.4 Replacing the Q-matic PC

If the Q-matic PC is no longer working, buying one from a BERNINA specialist is recommended. This has the advantage that all programs that are required for the Q-matic system are already installed. This guarantees compatibility with the entire Q-matic system. So the new PC merely needs to be installed and connected.

10 Errors and Faults

10.1 Troubleshooting

Fault	Cause	Solution
The Q-matic doesn't start.	The emergency stop button is still activated.	> To release the emergency stop button, turn the red button in the direction of the arrow.
	Q-matic is not switched on.	> Press and hold the green button for three seconds until you hear a click.
	LEDs illuminate or flash after the start-up process on the control and power supply cabinet or X/Y drives.	> Further information (see page 64).
«Safe Area» cannot be set.	Coupling of the X and Y belt clamp is not closed.	> Ensure that the couplings of the X and Y belt clamps are closed.
Design is not correctly sewn out.	Design is only sewn in the Y-axis or X-axis.	> Ensure that the couplings of the X and Y belt clamps are closed.
Too little free memory on the BERNINA USB stick.	Not enough free memory available on the BERNINA USB stick.	> Make sure that the BERNINA USB stick is being used. > Delete data from the BERNINA USB stick.
No BERNINA USB stick is inserted.	No BERNINA USB stick has been inserted.	> Use a BERNINA USB stick with enough free memory. > Make sure that throughout the entire update the same BERNINA USB stick always remains inserted.
After pushing the machine, the machine moves further on its own.	Easy Glide is set too high.	> Change the Easy Glide Setting. (see page 55)
Q-matic screen remains black	Computer is in energy-saving mode or in sleep mode.	> Press the on/off button on the screen.
	The Q-matic has not been started because the green button was pressed only briefly.	> Press and hold the green button for three seconds until you hear a click.

10.2 Error messages Q-matic software

Message on the Display	Cause	Solution
The system has reported a fault: A thread break fault has occurred.	The upper thread is used up.	> Rethread. Restart the machine with «Start», (see page 53).
	The upper thread is broken.	

Message on the Display	Cause	Solution
The system has reported a fault: A thread break fault has occurred.	The bobbin thread is used up.	> Rethread. Restart the machine with «Start», (see page 53).
	The bobbin thread is broken.	> Clean the hook. > Rethread. Restart the machine with «Start», (see page 53).
The system has reported a fault: There is a problem with the machine. Please check the sewhead.	The machine is not switched on.	> Switch the machine on.
	Connecting cable to Q-matic system not plugged in.	> Plug in cable.
A design is partially outside of the safe area or there are no queued designs in the safe area.	A design is partially outside of the «Safe Area».	> Reposition the design in the «Safe Area» or realign the «Safe Area». (see page 41) > Requeue the design. (see page 51)
The system has reported a fault: The controller has lost communication with the motor drives. Please ensure the STOP button is not pressed.	The motor drive is not working. Both or just one of the LED indicator lights are/is illuminated in «orange» on the X/Y drive.	> Ensure that the connectors of both cables are correctly inserted or are not defective. – Both LED indicator lights are illuminated in «green». > Realign the «Safe Area». (see page 41) > Restart the machine with «Start».
The system has reported a fault: An X-axis fault has occurred. The controller has lost communication with the motor drives. Please ensure the STOP button is not pressed.	The X/Y drive control system is not working. Both or just one of the LED indicator lights are/is illuminated in «orange» on the X/Y drive.	> Ensure that the connectors of both cables are correctly inserted or are not defective. – Both LED indicator lights are illuminated in «green». > Realign the «Safe Area». (see page 41) > Restart the machine with «Start».
The system has reported a fault: A needle fault has occurred.	Moving the handwheel while positioning the sewhead.	> Restart the Q-matic system.
The sewhead is too far away from any design. Please reposition the sewhead then click Start.	The sewhead is too far away from the design.	> Move the sewhead closer to the design.
The system has reported a fault: A sequence fault has occurred.	The machine is not switched on. Machine is using an old firmware version.	> Switch the machine on. > Update the machine firmware.
The system has reported a fault: Unable to sew because designs are too large.	The design is too large. The created design is too long (length or number of stitches) and can therefore not be processed.	> Make the design smaller or divide the design into smaller pieces in «Art & Stitch».



10.3 Q-matic system status and troubleshooting

System Status Display

LEDs display the system status on the control cabinet, as well as on both drive motors.



Fig. 1: LEDs on the control cabinet



Fig. 2: LEDs on the drive motors

Troubleshooting

During the start-up process, all the LEDs illuminate and flash. As soon as the system has started up error-free, only the green LEDs will illuminate. If, after starting, other LEDs illuminate or flash, there is an error.

- > If there is an error, switch off the system and disconnect it completely from the power supply.
- > Plug in the power cable again and restart the system.
- > If the error persists after the second restart, switch off the system.
- > Check whether the USB cable is correctly connected to the Q-matic PC. Reconnect the cable if required.
- > Check whether the power cable to the machine is correctly connected. Reconnect the cable if required.
- > Restart the system again.
- > If the error persists, contact a BERNINA specialist or BERNINA technical support.

11 Appendix

11.1 Overview Quilt Designs

Tips around the Quilt Designs

The designs are digitized geometrically with great precision. The Q-matic system also sews these out very accurately. Nevertheless, inaccuracies may be visible with large designs due to shrinkage of the fabric layers during the quilting process.

Measures to Minimize Shrinkage

- Before beginning to quilt, stabilize the quilt block and the quilt sandwich with basting stitches.
- For designs with frames, always sew first the outer and then the inner portions.
- Clamp both the top of the quilt and the backing fabric, i.e. do not simply float the fabric.
- Clamp the backing fabric on the side with side clamps. Never change this clamping during quilting.
- Do not lean or support your arms on the front rails during quilting.
- In case of extreme enlargements or reductions of the designs, first sew out a quilt sample.



Jump Stitch







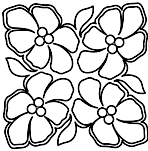
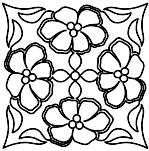
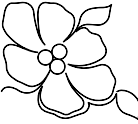
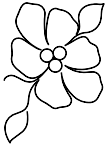

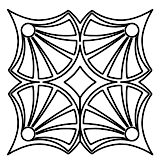
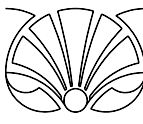
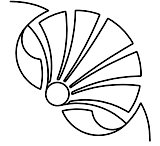
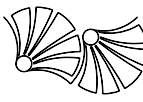
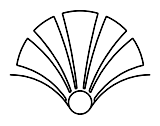
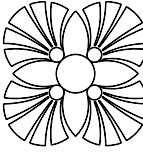

For some designs, the machine must jump from one place to another without sewing, so as to continue sewing there. These jumps from one point to another are named jump stitch. Q-matic can be set so that the machine stops before a jump stitch, for the purpose of securing and to cut the thread. If the setting is deactivated, a long stitch is created which must later be processed. Designs that contain jump stitches are marked in the design overview with the number of jump stitches.



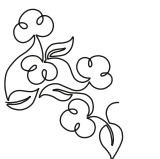
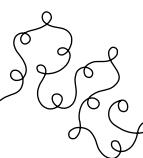



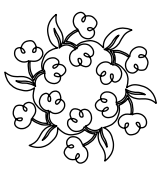
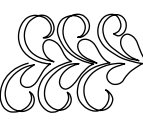





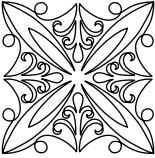



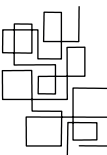

Supplied Designs



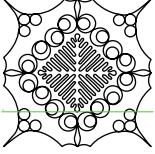

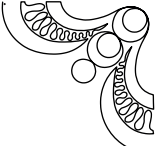
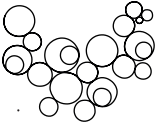









To find further information on the well-known designers and quilters who created the designs included in BERNINA Q-matic, please search for their names online and visit their websites or blogs. Q-matic includes designs from Amanda Murphy, Keryn Emmerson, Patricia Ritter, Aggy Burczyk, Basic Shapes by AB, Alfonsina Uriburu, Linzi Upton, Gerda Raschle, Lisa Calle, OESD, etc..

Amanda Murphy



Name	Quilt Design	Name	Quilt Design
AM_Bloom_Block1		AM_Bloom_Block2	
AM_Bloom_Borders		AM_Bloom_corner	
AM_Bloom_E2E		AM_Bloom_Motif	















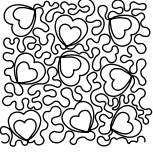

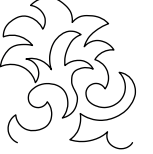

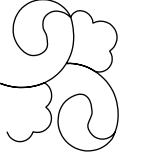

Name	Quilt Design	Name	Quilt Design
AM_Bloom_Triangle		AM_ModernArcs_Block	
AM_ModernArcs_Border		AM_ModernArcs_Corner	
AM_ModernArcs_E2E1		AM_ModernArcs_E2E2	
AM_ModernArcs_Motif		AM_ModernArcs_Triangle	
LoopedFlowers_Border		LoopedFlowers_Border_L	
LoopedFlowers_Corner		LoopedFlowers_Panto1	
LoopedFlowers_Panto2		LoopedFlowers_Panto3	
LoopedFlowers_Segment		LoopedFlowers_Square	
LoopedFlowers_Triangle		LoopedFlowers_Wreath	
LooseSwirlFeathers_Border		LooseSwirlFeathers_Corner	



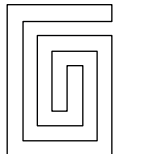
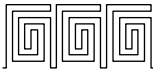

Name	Quilt Design	Name	Quilt Design
LooseSwirlFeathers_Panto		LooseSwirlFeathers_Segment	
LooseSwirlFeathers_Square		LooseSwirlFeathers_Triangle	
Panto_Candle		Panto_Hearts1* *Pantograph can only be formed with «Panto_Hearts2»	
Panto_Hearts2* *Pantograph can only be formed with «Panto_Hearts1»		Panto_LooseSwirls	
Panto_Square Meander		Panto_Stars	
Panto_SwirlFlower		Panto_Swirls	
PebblesShell_Square Jumpstitch: 1		PebblesShells_Border	
PebblesShells_Corner		PebblesShells_Panto	
PebblesShells_Segment		PebblesShells_Triangle	
PebblesShells_Wreath		SwirlsPaisley_Border	

Name	Quilt Design	Name	Quilt Design
SwirlsPaisley_Corner		SwirlsPaisley_Panto	
SwirlsPaisley_Segment		SwirlsPaisley_Square1	
SwirlsPaisley_Square2		SwirlsPaisley_Triangle	
SwirlsPaisley_Wreath		TightSwirls_Continuous	
VinesBerries_Block		VinesBerries_Border	
VinesBerries_Border2		VinesBerries_Corner	
VinesBerries_Panto		VinesBerries_Triangle	
VinesBerries_Wreath			





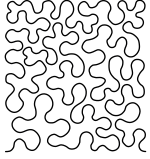







Keryn Emmerson







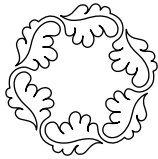

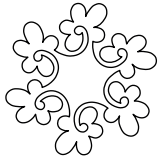













Name	Quilt design	Name	Quilt design
Bellflower		Bellflower2	

Name	Quilt design	Name	Quilt design
Bramble		Bramble2	
Camelia		Camelia2	
Cherish		Cherish2	
China grove		China grove2	
China sea		China sea2	
Cottontop		Cottontop2	
Leafarama		Leafarama2	
Offkilter		Offkilter2	
Scrap paper		Scrap paper2	
Smoke		Smoke2	
Star & crescent		Star & crescent2	

Name	Quilt design	Name	Quilt design
Streamer		Streamer2	
Tangle		Villette	
Villette2			









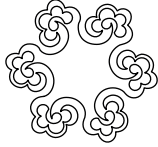

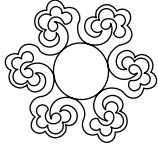
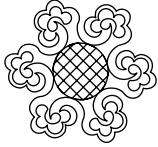
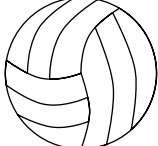

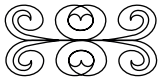

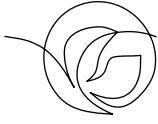
Patricia Ritter

Name	Quilt design	Name	Quilt design
Aloha Block Petite Corner_PR053		Aloha Block1_PR009	
Aloha Block2_PR010		Aloha Petite_ PRPANTO10	
Aloha Sashings_ PRPANTO35		Aralia	
Leaf Sashing1		Morning Glory	
PR007		PR011	
PR012		PR016	
PR082		PR0125	

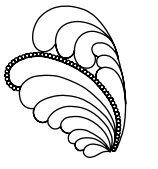
Name	Quilt design	Name	Quilt design
PR126		PR127	
PR128		PRPANTO01	
PRPANTO21		PRPANTO47	
PRPANTO64		PRPANTO65	
PRPANTO68		PRPANTO68_gross	
PRPANTO83		PRPANTO100	
PRPANTO110		PRPANTO131	
PRPANTO145		PRPANTO150	
PRPANTO151		PRPANTO152	
PRPANTO189		PRPANTO321	
PRPANTO489		Rebekah's rose	

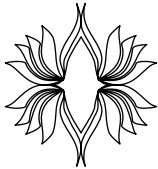
Aggy Burczyk



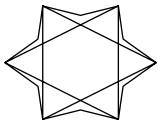

Name	Quilt design	Name	Quilt design
Ayana_basic		Ayana_block_01	

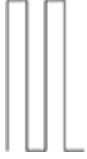

Name	Quilt design	Name	Quilt design
Ayana_block_02		Ayana_block_03 Jump stitch: 1	
Ball_01		Bellini_01	
Bellini_02		Butterfly_01	
Butterfly_01_E2E		Butterfly_02	
Butterfly_03_E2E		Circles	
Denebola		Feathers and Pearls_01	
Feathers and Pearls_02 Jump stitches: 3		Georgette_01	
Georgette_02		Half Moon_Border_01	
Half Moon_Border_02		Half Moon_Border_03 Jump stitches: 2	
Half Moon_Border_03_XS Jump stitches: 3		Hexagon_fill_01	

Name	Quilt design	Name	Quilt design
Hexagon_fill_02		Hexagon_fill_03	
Hexagon_fill_04		Hexagon_fill_05	
Pearls on a string		Pearls on a string_heart	
Pearls on a string_ring		Pearls_basic	
Skijumper		Square_fill_01	
Square_fill_02		Swirl_01	
Waves_Circles_double		Waves_Circles_single	

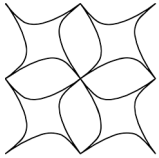

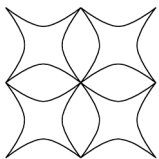
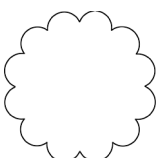
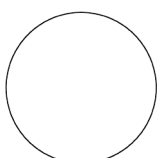
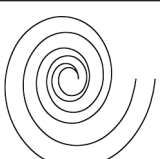
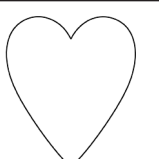
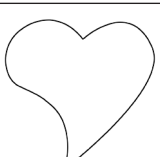
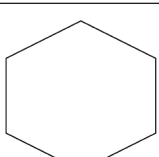
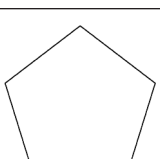
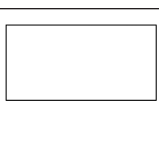
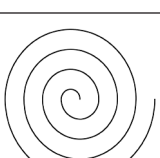
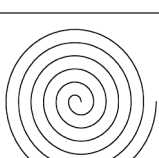
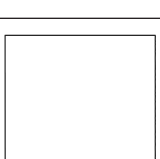
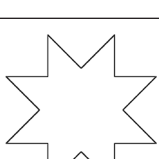

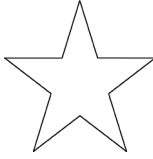
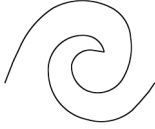
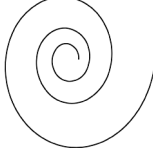
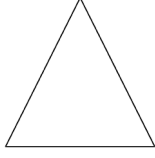

Basic Shapes by AB

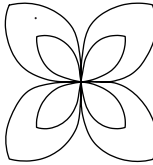
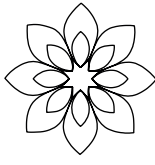
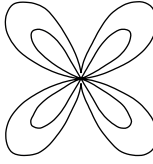
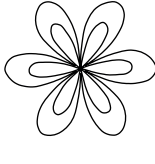

Name	Quilt design	Name	Quilt design
Basics_01		Basics_02	
Basics_03		Basics_04	

Name	Quilt design	Name	Quilt design
Basics_05		Basics_06	
Basics_07		Basics_08	
Basics_09		Basics_10	
Cake		Circle	
Double_Swirl_3		Heart_01	
Heart_02		Hexagon	
Pentagon		Rectangle_ASS	
Spiral_4		Spiral_6	
Square		Star_01	



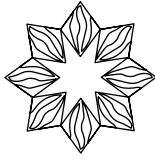
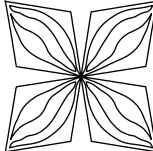
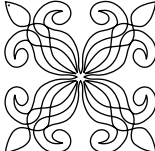

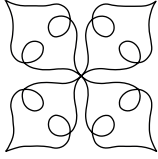
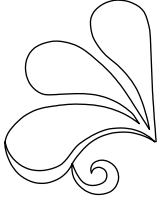
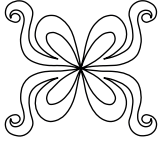
Name	Quilt design	Name	Quilt design
Star_02		Swirl_basic	
Swirl_3		Triangle	
Waves_basic			

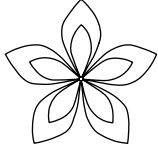
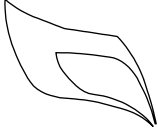
Alfonsina Uriburu



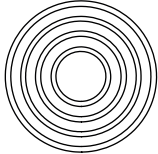
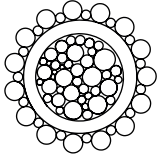
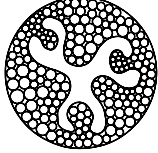
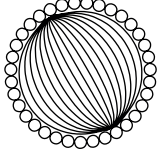

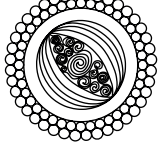
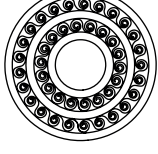

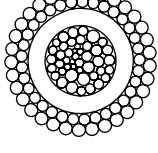

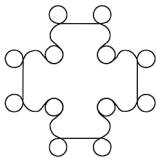
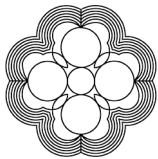

Name	Quilt design	Name	Quilt design
Celia1		Celia3	
Delia1		Delia3	
Elina1		Elina2	
Heart line		Heart line2_1	
Hock block		Julia	
Julia block		Laura Block	

Name	Quilt design	Name	Quilt design
Lilli		Lourdes	
Mejillon block		Patricia	
Petal		Petal element	

Linzi Upton

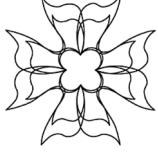
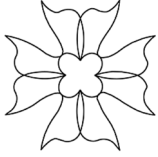

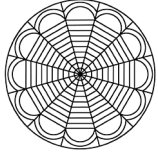
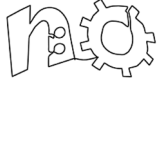
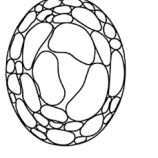
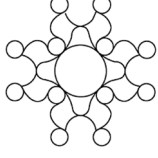
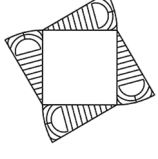
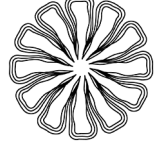

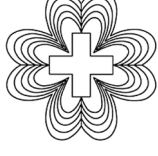



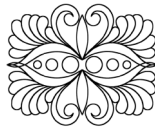

Name	Quilt design	Name	Quilt design
QE1 Jump stitches: 7		QE5 Jump stitch: 1	
QE9		QE10	
QE11		QE12	
QE13 Jump stitches: 1		QE18 Jump stitches: 3	
QE19 Jump stitches: 4		QE23 Jump stitch: 1	

Gerda Raschle



Name	Quilt design	Name	Quilt design
Ball_Block		Circle_Flower	
Dog-foot		Fantasy	
Feet		Feet_1	
Fingerprint		Flower_evergreen_02	
Flower_evergreen_01		Hands	
Mandala		no	
Ovale_Stone		Pebbles Square	
Pictures Frame		Rosa	
Row of houses		Swiss_Flower	



Name	Quilt design	Name	Quilt design
Yes			

Lisa Calle

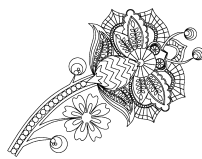
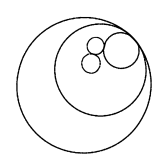
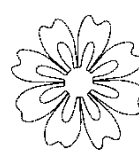



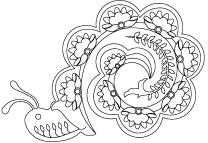

Name	Quilt design	Name	Quilt design
LC 13 Swan's Journey Block 2		LC 13V1 Swan's Journey Block 2A Jump stitches: 5	
LC 13V2 Swan's Journey Block 1 Jump stitches: 7		LC 14 Swan's Journey Corner Large Jump stitch: 1	
LC 15 Swan's Journey Corner Sm Jump stitch: 1		LC 16 Swan's Journey Frame	
LCPANTO24 Swan's Journey BDR		LCPANTO25 Swan's Journey Panto LG	
LCPANTO26 Swan's Journey Small		LCPANTO27 Swan's Journey Sash	



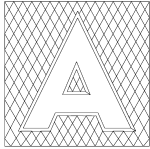

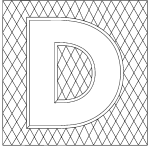
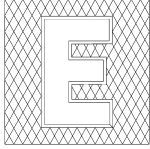
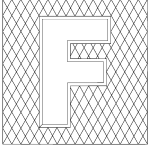

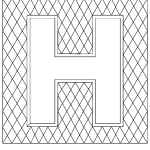
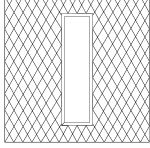
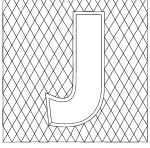
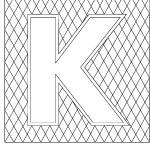
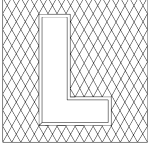
Tula Pink

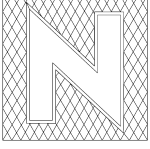
Name	Quilt Design	Name	Quilt Design
TP_BandBee_1 Jump stitches: 5		TP_BandBee_2 Jump stitches: 6	
TP_BandBee_Circle		TP_BandBee_Flower	
TP_FeatherPaisley_1 Jump stitches: 2		TP_FeatherPaisley_2 Jump stitches: 2	

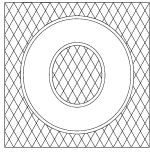
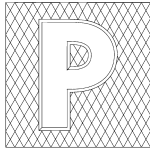

Name	Quilt Design	Name	Quilt Design
TP_FeatherPaisley_Original		TP_Snail_1 Jump stitches: 2	
TP_Snail_2 Jump stitch: 1		TP_Snail_Original Jump stitches: 2	

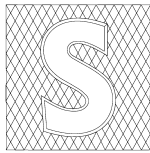
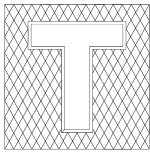
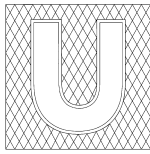
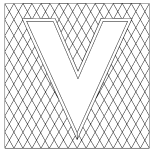
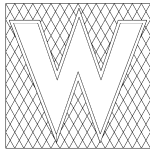
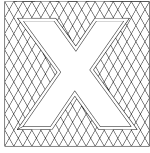
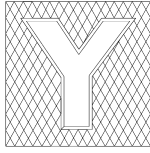

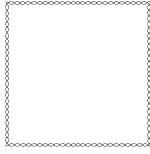
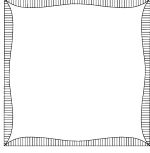









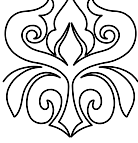

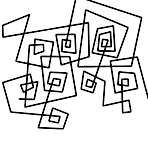
Sarah Vedeler

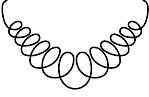
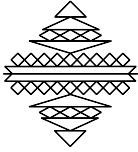



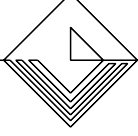
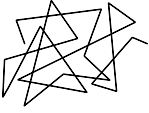

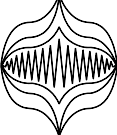







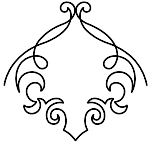

Name	Quilt Design	Name	Quilt Design
SV_A Jump stitches: 4		SV_B Jump stitches: 3	
SV_C Jump stitch: 1		SV_D Jump stitches: 2	
SV_E Jump stitch: 1		SV_F Jump stitches: 2	
SV_G Jump stitches: 3		SV_H Jump stitch: 1	
SV_I Jump stitches: 2		SV_J Jump stitch: 1	
SV_K Jump stitches: 4		SV_L Jump stitch: 1	
SV_M Jump stitch: 1		SV_N Jump stitch: 1	

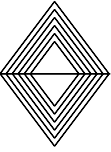
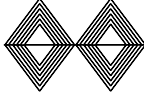



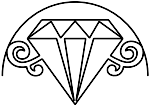



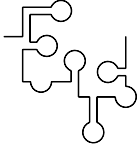

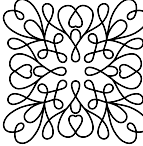
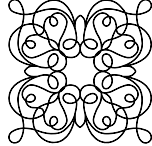
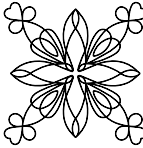
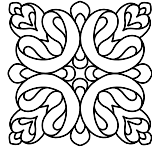
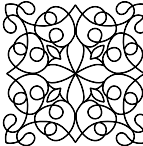
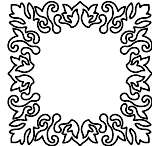

Name	Quilt Design	Name	Quilt Design
SV_O Jump stitches: 4		SV_P Jump stitches: 2	
SV_Q Jump stitches: 4		SV_Q_with border Jump stitches: 6	
SV_R Jump stitches: 4		SV_S Jump stitches: 3	
SV_T Jump stitches: 4		SV_U Jump stitches: 5	
SV_V Jump stitches: 3		SV_W Jump stitch: 1	
SV_X Jump stitch: 1		SV_Y Jump stitches: 4	
SV_Z Jump stitch: 1		SV_Inner border	
SV_Outer border			

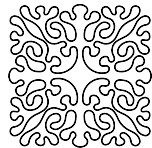
OESD

Name	Quilt Design	Name	Quilt Design
12380-04		12380-08	

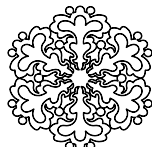
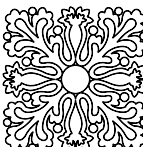
Name	Quilt Design	Name	Quilt Design
12380-09		12380-10	
32196-01		32196-01-B	
32196-02		32196-03	
32196-04		32196-05	
32196-06		32196-07	
32196-07-B		32196-08	
32196-09		32196-10	
32196-10-B		32196-11	
32196-12		32196-12-B	

Name	Quilt Design	Name	Quilt Design
32196-13		32196-13-B	
32196-14		32196-15	
32196-16		32196-17	
32196-18		32196-19	
32196-21		32196-21-B	
32196-22		32196-23	
32196-23-B		32196-24	
32196-24-B		32196-25	
32196-27		32196-28	

Name	Quilt Design	Name	Quilt Design
32196-29		32196-30-B	
BD285		BD289-01	
BD292-01		BD299-01	
BD308-01		BD394	
BD412-01		BD413-01	
BD513		BD513-B	
BD514		BD553-01	
BD554		BD567	
BD659-B		BD665	

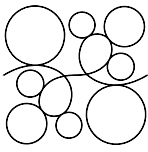
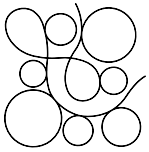
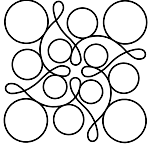
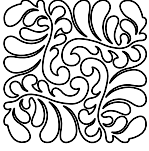
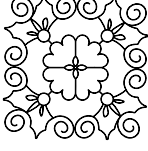
Name	Quilt Design	Name	Quilt Design
BD800		BD801	
BD804-01		BD837	
HE959-01			

Index

A

Activate/Deactivate Sounds	55
Align Designs	37
Altering the Design Size	38
Assign Tags	49

C

Cancel Sewing	54
Change Sewing Direction	35
Connect Design	35
Copy Design	28
Create New Quilting Project	45
Create Pantograph	40

D

Delete Design	28, 47
Delete Quilting Project	45
Design	
Place exactly	22

E

Emergency Stop Button	50
Explanation of Symbols	7

G

Grab and Drop	27
---------------------	----

I

Import Design	46
Internet Usage	7
Interrupt Sewing of Design	52
Introduction	8

J

Jump Stitch	65
-------------------	----

M

Markers	23
Masking the Design	30
With Shape	31
MicroMove	22
Mirror Design	30
Move Design	28
Move Machine Manually	55
Multiply	27

O

Open Quilting Project	45
Overview of Design	65
Overview of Tool Center	15
Overview of User Interface	11

Q

Q-matic Software Error Messages	62
Queue	51
Quilt Design Area	14
Quilt Size	20

R

Realigning the Safe Area	41
Reinstall Art & Stitch	61
Reinstall or Update the Q-matic Software/Firmware	57
Reinstall Windows	57
Remove Design from Design Center	47
Replace Q-matic PC	61
Rotate Design	28

S

Safety Instructions	5
Save Design	46
Save Quilting Project	45
Securing Options	51
Select a Design	21
Separate Designs	36
Set Boundary	23
Set the Safe Area	20
Sew Design	52
Sewing On/Off	55
Sewing Sequence	51
Start Q-matic	19
Switch Securing On/Off	55

T

Tag Designs	48
Thread Break, continue sewing	53
Trimming the Design	32
Troubleshooting	62

U

Update Art & Stitch	61
---------------------------	----



BERNINA recommends threads from *Mettler*[®]

BERNINA International AG | CH-8266 Steckborn, Switzerland | www.bernina.com | © Copyright by BERNINA International AG

1018305_10A_04
2023-01 EN

made to create **BERNINA**